

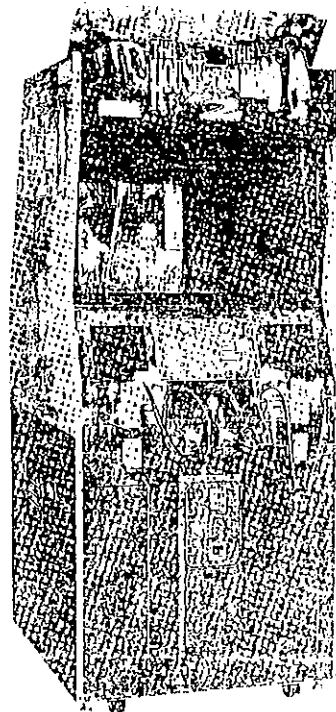

U/R TYPE

OWNER'S MANUAL



SEGA ENTERPRISES, LTD.

MANUAL NO. 420 - 6428 - 04

Downing the boss character awaiting you at the end of each stage results in clearing that particular stage. The player can not defeat the boss until his life meter becomes zero.

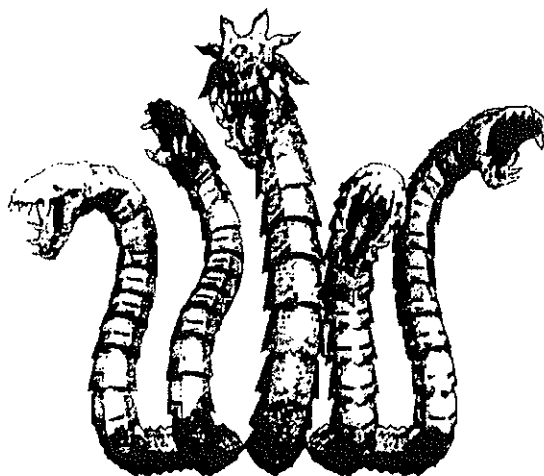
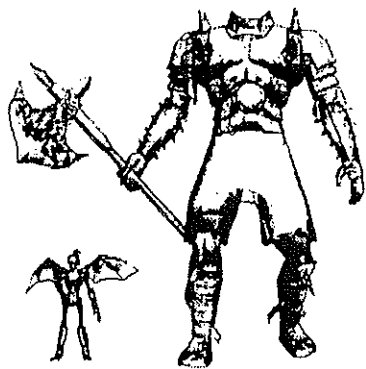

- ④ If you would like to join in the game at anytime while the other person is playing, insert a coin(s) and press the start button. Also, when credits allowing the game to be played still remain, the start button on the other side will keep flashing. The player can participate in the game by pressing the flashing button.
- ⑤ When the life point becomes zero, if you want to continue, insert a coin(s) required to continue and press the start button. If credits allowing the player to continue still remain, you can continue by merely pressing the start button.
- ⑥ At the time of game over, if the player's score ranks 10th or higher, his name can be entered.

CONCERNING SPECIAL ITEMS

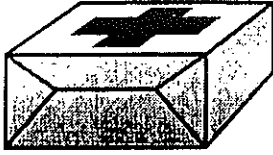

LIFE

The life point increases by one.
MAX. No. of LIFE: 5



COIN or GOLDEN FROG

Capture a Coin or Golden Frog to earn points.

KNACK OF PLAY

- **Accurately shoot at the head:**
In each stage, the head part is the weak point of the enemy characters other than the Boss. Hitting the head greatly decreases the enemy's life points and can down the enemy quickly. In the latter half of the stages, the higher the stage level you proceed to, the more important the shooting accuracy becomes.
- **Look for your favorite routes:**
The stage has various routes which are determined by the player's action. Some routes have less enemy appearance, frequent life recovery, etc. You can master a knack of play by looking for your favorite routes.
- **Memorizing the enemy's appearance position:**
Since the enemy's appearance pattern is the same every time, you can also master a knack of play by memorizing such pattern through repeated game play.

WEAK POINT



9. EXPLANATION OF TEST AND DATA DISPLAY

By operating the switch unit, periodically perform the tests and data check. When installing the machine initially or collecting cash, or when the machine does not function correctly, perform checking in accordance with the explanations given in this section.

The following shows tests and modes that should be utilized as applicable.

TABLE 8 EXPLANATION OF TEST MODE

ITEMS	DESCRIPTION	REFERENCE SECTIONS
INSTALLATION OF MACHINE	When the machine is installed, perform the following: 1. Check to see that each setting is as per standard setting made at the time of shipment. 2. In the INPUT TEST mode, check such input devices as each SW, V.R., etc. 3. In the OUTPUT TEST mode, check such output devices as lamps, motors, etc. 4. In the SELF-TEST mode, check ICs on the IC Board.	9 - 2 ③, 9 - 3 ⑤ 9 - 3 ② 9 - 3 ③ 9 - 2 ①
MEMORY	Choose MEMORY TEST in the MENU mode to allow the MEMORY test to be performed. In this test, PROGRAM RAMs, ROMs, and ICs on the IC Board are checked.	9 - 2 ①
PERIODIC SERVICING	Periodically perform the following: 1. MEMORY TEST 2. Ascertain each setting. 3. In the INPUT TEST mode, test the CONTROL device 4. In the OUTPUT TEST mode, check such output devices as lamps, motors, etc.	9 - 2 ① 9 - 2 ③, 9 - 3 ⑤ 9 - 3 ② 9 - 3 ③
CONTROL SYSTEM	1. In the INPUT TEST mode, check such input devices as each SW, V.R., etc. 2. Adjust or replace each SW and VR. 3. If the problem can not be solved yet, check the CONTROL's moves.	9 - 3 ② 1 0
MONITOR	In the MONITOR ADJUSTMENT mode, check to see if the MONITOR adjustment is appropriately made.	9 - 2 ② 1 2
IC BOARD	1. MEMORY TEST 2. In the SOUND TEST mode, check the sound related ROMs.	9 - 2 ① 9 - 3 ④
DATA CHECK	Check such data as game play time and histogram to adjust the difficulty level, etc.	9 - 2 ⑤, 9 - 3 ⑦

9-1 SWITCH UNIT AND COIN METER



Never touch places other than those specified. Touching places not specified can cause electric shock and short circuit hazards.



- Adjust to the optimum sound volume by considering the environmental requirements of the installation location.
- If the COIN METER and the game board are electrically disconnected, game play is not possible.

SWITCH UNIT

Open the coin chute door, and the switch unit shown will appear.
The functioning of each SW is as follows:

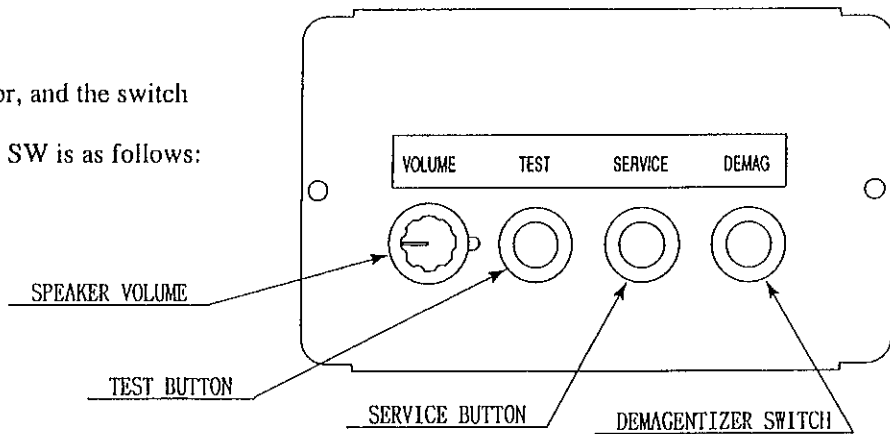

FIG. 9.1 a SWITCH UNIT

TEST BUTTON:
TEST

For the handling of the test button, refer to the following pages.

SERVICE BUTTON:
SERVICE

Gives credits without registering on the coin meter.

SPEAKER VOLUME:
SPEAKER

Adjusts sound volume for all of the machines' Speakers. Adjust to an appropriate sound volume by considering the environmental requirements of the installation location.

DEMAGNETIZER SWITCH:
DEMAG.

Eliminates the on-screen color unevenness due to magnetization of CRT. First use this SW before performing the monitor's color adjustment.

COIN METER

Open the Cashbox Door by using the key to have the Coin Meter appear underneath the Cashbox.

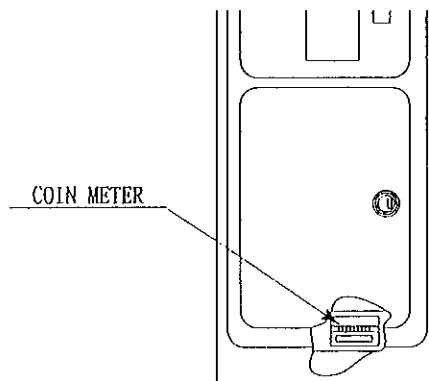

FIG. 9.1 b

9-2 NAOMI TEST MODE

NAOMI GAME BOARD is employed in this product. This Game BD allows another game to be played by replacing the Cartridge. In this product, however, only The House of The Dead 2 is playable. For this system, the Test Mode for the system (NAOMI Test Mode) and the Game Test Mode of THE HOUSE OF THE DEAD 2 are available.

NAOMI Test Mode mainly allows the functioning of board to be checked, monitor adjustment to be checked, and coin assignments to be set.

- テストモード中にて設定変更した場合は、メニュー画面の"EXIT"を選択してテストモードを終了してください。テストモードを終了しないで、電源を切ると、変更した設定は無効になります。
- Executing "BACKUP DATA CLEAR" in the NAOMI Test Mode also clears the BOOKKEEPING DATA in the Game Test Mode.

TEST MODE OPERATION METHOD

After turning power on, press the TEST button to display the menu screen of NAOMI Test Mode. To execute the Game Test Mode, select GAME TEST MODE in the menu mode. Carefully read the explanations of 9-3.

- ① Press the TEST button to display the menu screen of NAOMI Test Mode.
- ② Press the SERVICE button to move the arrow. Bring the arrow to the desired item.
- ③ Press the TEST button to execute the item indicated by the arrow.
- ④ After finishing the test, select EXIT and press the TEST button. The TEST mode is completed and the Game mode returns on to the screen.

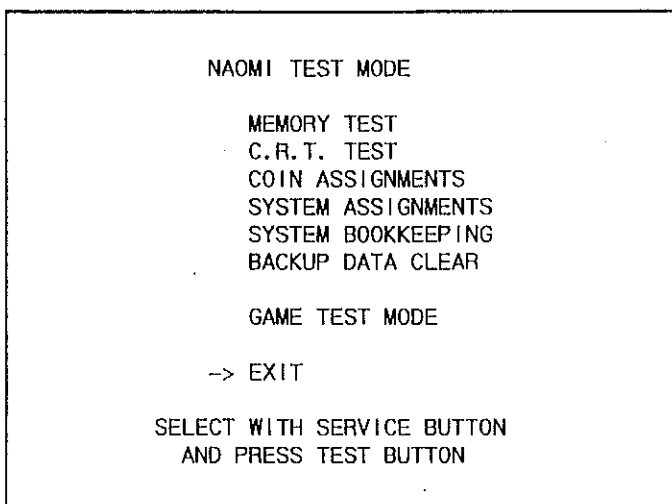

FIG. 9. 2 a Menu Screen, NAOMI TEST MODE

① MEMORY TEST

First, check if MEMORY IC functioning on the Main Board is accurate. If the IC is in good operating condition, "GOOD" will be indicated. If there exists any malfunctioning of the IC's, "BAD" will be indicated.

```
MEMORY TEST MODE

RAM TEST

IC29 GOOD
IC34 GOOD
IC16 GOOD IC18 GOOD
IC20 GOOD IC22 GOOD
IC9 GOOD IC10 GOOD
IC11 GOOD IC12 GOOD

PRESS TEST BUTTON TO CONTINUE
```

FIG. 9. 2 b MEMORY TEST MODE (RAM TEST)

After the completion of test, press the TEST button to execute ROM test.

```
MEMORY TEST MODE

ROM TEST

IC22 (ROM0) GOOD IC1 (ROM1) GOOD
IC2 (ROM2) GOOD IC3 (ROM3) GOOD
IC4 (ROM4) GOOD IC5 (ROM5) GOOD
IC6 (ROM6) GOOD IC7 (ROM7) GOOD
IC8 (ROM8) GOOD IC9 (ROM9) GOOD
IC10 (ROM10) GOOD IC11 (ROM11) GOOD
IC12 (ROM12) GOOD IC13 (ROM13) GOOD
IC14 (ROM14) GOOD IC15 (ROM15) GOOD
IC16 (ROM16) GOOD IC17 (ROM17) GOOD
IC18 (ROM18) GOOD IC19 (ROM19) GOOD
IC20 (ROM20) GOOD

PRESS TEST BUTTON TO EXIT
```

FIG. 9. 2 c MEMORY TEST MODE (ROM TEST)

If the IC is in good operating condition, "GOOD" will be indicated. If there exists any malfunctioning of the IC's, "BAD" will be indicated.

After the test has been completed, press the TEST button to return to the menu mode.

② C. R. T. T E S T

A) RGB COLOR ADJUSTMENT SCREEN

This page allows the monitor's color adjustment to be checked.

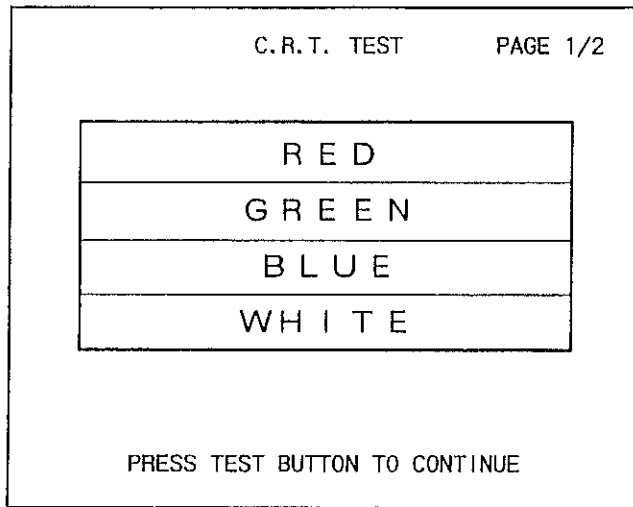

FIG. 9. 2 d C.R.T. TEST (1/2)

Each of red, green and blue is the darkest at the leftmost end and becomes brighter towards the right-hand end.

The monitor brightness is satisfactory if the white color bar is black at the left-hand end and white at the right-hand end.

Press the TEST button to have the size check screen appear.

B) MONITOR SIZE ADJUSTMENT SCREEN

This page allows monitor size to be checked.

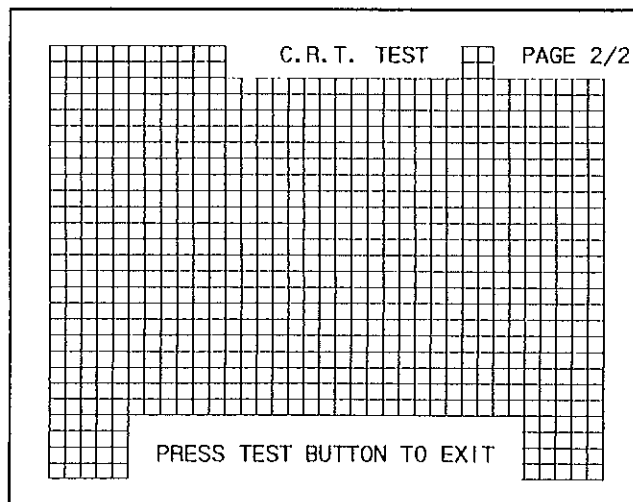

FIG. 9. 2 e C.R.T. TEST (2/2)

Make adjustment in the manner so that crosshatches do not go beyond the screen.

Press the TEST button to have MENU return to the screen.

③ COIN ASSIGNMENTS



Changing the settings in COIN ASSIGNMENTS clears BOOKKEEPING DATA of SYSTEM BOOKKEEPING and Game Test Mode.

In this mode, the setting of credit increments, etc., as against coin insertion can be changed.

- 1) Press the SERVICE button to bring the "->" to the desired item.
- 2) Press the TEST button to change the setting.
- 3) When settings are completed, move the arrow to EXIT and press the TEST button.

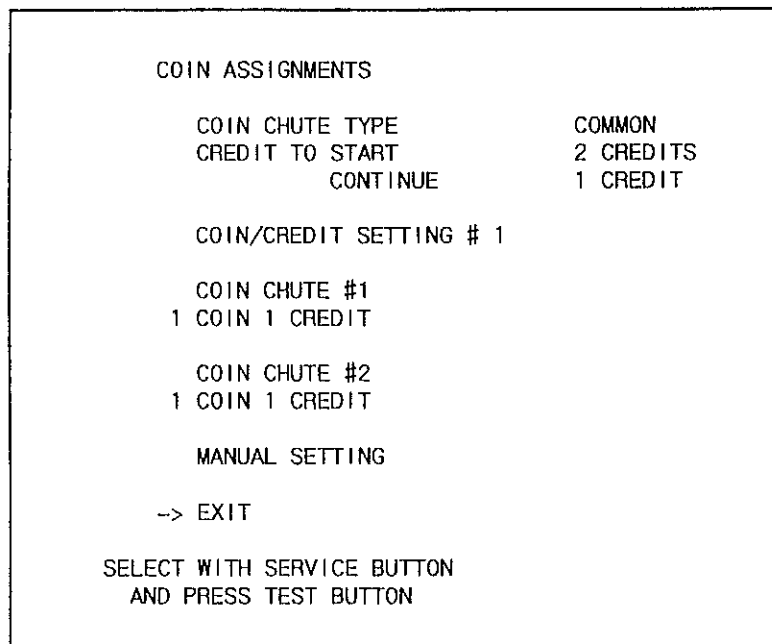

FIG. 9. 2 f COIN ASSIGNMENTS

- (A) COIN CHUTE TYPE (COMMON, INDIVIDUAL)
Set to COMMON.

COMMON

Used for the type of the cabinet whose coin acceptance is a common type for plural players. Regardless of the number of players, COIN 1/COIN 2 ports are used.

INDIVIDUAL

Not used.

- (B) CREDIT TO START (1 CREDIT, 2 CREDITS)
Sets the number of credits necessary to start game.

- (C) CREDIT TO CONTINUE (1 CREDIT~5 CREDITS)
Sets the number of credits necessary to continue game.

(D) COIN/CREDIT SETTING (# 1~# 27)

Set the CREDIT increase increment per coin insertion. There are 27 settings from #1 to #26, expressed in ○○ credits as against ○○ COINS inserted. #27 refers to FREE PLAY. For details, refer to Table 1 (COMMON).

(E) MANUAL SETTING

The CREDIT's incremental increase settings as against a coin insertion are shown in further details than in (D) above (refer to Table 2). Also, note that when this MANUAL setting is performed, the COIN/CREDIT setting becomes ineffective.

MANUAL SETTING SCREEN

COIN ASSIGNMENTS									
MANUAL SETTING									
COIN TO CREDIT 1 COIN 1 CREDIT									
BONUS ADDER					NO BONUS ADDER				
COIN CHUTE #1 MULTIPLIER									
1 COIN COUNT AS 1 COIN									
COIN	1	2	3	4	5	6	7	8	9
CREDIT	1	2	3	4	5	6	7	8	9
COIN CHUTE #2 MULTIPLIER									
1 COIN COUNT AS 1 COIN									
COIN	1	2	3	4	5	6	7	8	9
CREDIT	1	2	3	4	5	6	7	8	9
-> EXIT									
SELECT WITH SERVICE BUTTON AND PRESS TEST BUTTON									

FIG. 9. 2 g MANUAL SETTING

(F) COIN TO CREDIT

Determines COIN/CREDIT setting.

(G) BONUS ADDER

This sets how many COINS should be inserted to obtain one SERVICE COIN.

(H) COIN CHUTE # 1/# 2 MULTIPLIER

This sets how many tokens one COIN represents.

TABLE I COIN/CREDIT SETTING

NAME OF SETTING	FUNCTIONING OF COIN CHUTE #1		FUNCTIONING OF COIN CHUTE #2	
SETTING #1	1 COIN	1 CREDIT	1 COIN	1 CREDIT
SETTING #2	1 COIN	2 CREDITS	1 COIN	1 CREDIT
SETTING #3	1 COIN	3 CREDITS	1 COIN	1 CREDIT
SETTING #4	1 COIN	4 CREDITS	1 COIN	1 CREDIT
SETTING #5	1 COIN	5 CREDITS	1 COIN	1 CREDIT
SETTING #6	1 COIN	2 CREDITS	1 COIN	2 CREDITS
SETTING #7	1 COIN	5 CREDITS	1 COIN	2 CREDITS
SETTING #8	1 COIN	3 CREDITS	1 COIN	3 CREDITS
SETTING #9	1 COIN	4 CREDITS	1 COIN	4 CREDITS
SETTING #10	1 COIN	5 CREDITS	1 COIN	5 CREDITS
SETTING #11	1 COIN	6 CREDITS	1 COIN	6 CREDITS
SETTING #12	2 COINS	1 CREDIT	2 COINS	1 CREDIT
SETTING #13	1 COIN	1 CREDIT	2 COINS	1 CREDIT
SETTING #14	1 COIN	2 CREDITS	2 COINS	1 CREDIT
SETTING #15	1 COIN	1 CREDIT	1 COIN	1 CREDIT
	2 COINS	3 CREDITS	2 COINS	3 CREDITS
SETTING #16	1 COIN	3 CREDITS	1 COIN	1 CREDIT
			2 COINS	3 CREDITS
SETTING #17	3 COINS	1 CREDIT	3 COINS	1 CREDIT
SETTING #18	4 COINS	1 CREDIT	4 COINS	1 CREDIT
SETTING #19	1 COIN	1 CREDIT	1 COIN	1 CREDIT
	2 COINS	2 CREDITS	2 COINS	2 CREDITS
	3 COINS	3 CREDITS	3 COINS	3 CREDITS
	4 COINS	5 CREDITS	4 COINS	5 CREDITS
SETTING #20	1 COIN	5 CREDITS	1 COIN	1 CREDIT
			2 COINS	2 CREDITS
			3 COINS	3 CREDITS
			4 COINS	5 CREDITS
SETTING #21	5 COINS	1 CREDIT	5 COINS	1 CREDIT
SETTING #22	1 COIN	2 CREDITS	3 COINS	1 CREDIT
			5 COINS	2 CREDITS
SETTING #23	2 COINS	1 CREDIT	2 COINS	1 CREDIT
	4 COINS	2 CREDITS	4 COINS	2 CREDITS
	5 COINS	3 CREDITS	5 COINS	3 CREDITS
SETTING #24	1 COIN	3 CREDITS	2 COINS	1 CREDIT
			4 COINS	2 CREDITS
			5 COINS	3 CREDITS
SETTING #25	1 COIN	1 CREDIT	1 COIN	1 CREDIT
	2 COINS	2 CREDITS	2 COINS	2 CREDITS
	3 COINS	3 CREDITS	3 COINS	3 CREDITS
	4 COINS	4 CREDITS	4 COINS	4 CREDITS
	5 COINS	6 CREDITS	5 COINS	6 CREDITS
SETTING #26	1 COIN	6 CREDITS	1 COIN	1 CREDIT
			2 COINS	2 CREDITS
			3 COINS	3 CREDITS
			4 COINS	4 CREDITS
			5 COINS	6 CREDITS
SETTING #27	FREE PLAY		FREE PLAY	

Table 2 MANUAL SETTING

COIN TO CREDIT	1 COIN 1 CREDIT
	2 COINS 1 CREDIT
	3 COINS 1 CREDIT
	4 COINS 1 CREDIT
	5 COINS 1 CREDIT
	6 COINS 1 CREDIT
	7 COINS 1 CREDIT
	8 COINS 1 CREDIT
	9 COINS 1 CREDIT
BONUS ADDER	NO BONUS ADDER
	2 COINS GIVE 1 EXTRA COIN
	3 COINS GIVE 1 EXTRA COIN
	4 COINS GIVE 1 EXTRA COIN
	5 COINS GIVE 1 EXTRA COIN
	6 COINS GIVE 1 EXTRA COIN
	7 COINS GIVE 1 EXTRA COIN
	8 COINS GIVE 1 EXTRA COIN
	9 COINS GIVE 1 EXTRA COIN
COIN CHUTE (#1/#2) MULTIPLIER	1 COIN COUNTS AS 1 COIN
	1 COIN COUNTS AS 2 COINS
	1 COIN COUNTS AS 3 COINS
	1 COIN COUNTS AS 4 COINS
	1 COIN COUNTS AS 5 COINS
	1 COIN COUNTS AS 6 COINS
	1 COIN COUNTS AS 7 COINS
	1 COIN COUNTS AS 8 COINS
	1 COIN COUNTS AS 9 COINS

④ SYSTEM ASSIGNMENTS

The setting for sound output during advertise can be changed.
Settings of game itself such as difficulty level, etc. are performed in the Game Test Mode.

- 1) Press the SERVICE button to bring the arrow to ADVERTISE SOUND.
- 2) Press the TEST button to change the setting.
- 3) Move the arrow to EXIT and press the TEST button to return to the menu mode.

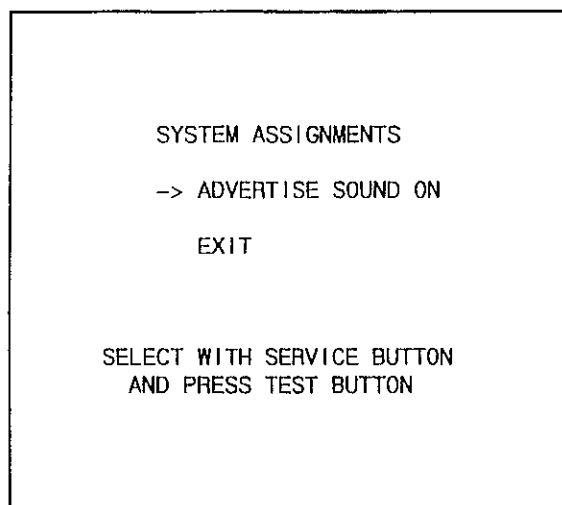

FIG. 9.2 h SYSTEM ASSIGNMENTS

⑤ SYSTEM BOOKKEEPING

Data for Number of coins inserted / Number of Credits can be checked.
Press the TEST button to have the MENU mode return to the screen.

SYSTEM BOOKKEEPING	
COIN CHUTE #1	0
COIN CHUTE #2	0
TOTAL COINS	0
COIN CREDITS	0
TOTAL CREDITS	0
SERVICE CREDITS	0

PRESS TEST BUTTON TO EXIT

FIG. 9. 2 i SYSTEM BOOKKEEPING

- COIN CHUTE #*: Number of coins put in each chute.
- TOTAL COINS: Total number of coins inserted.
- COIN CREDITS: Number of credits registered by inserting coins.
- TOTAL CREDITS: Total number of credits.
(COIN CREDITS + SERVICE CREDITS)
- SERVICE CREDITS: Credits registered by the SERVICE button.

⑥ BACKUP DATA CLEAR



IMPORTANT!

Executing BACKUP DATA CLEAR also clears BOOKKEEPING DATA in the Game Test Mode.

Clears SYSTEM BOOKKEEPING DATA.

When clearing, bring the arrow to "YES" and press the TEST button.

Move the arrow to "NO" and press the TEST button to return to the menu mode.

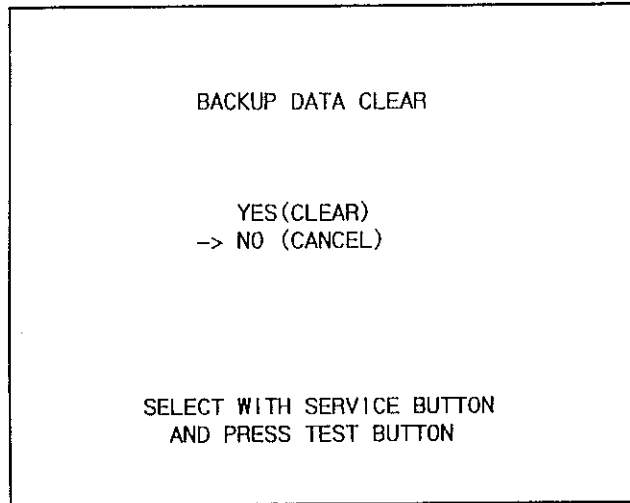

FIG. 9. 2j BACKUP DATA CLEAR

9-3 GAME TEST MODE

① INPUT TEST

The GAME TEST MODE proceeds from NAOMI TEST MODE.

Select each item by using the SERVICE button and execute with TEST button.

The SERVICE button corresponds to the Cabinet's Gun Trigger, and TEST button corresponds to the Cabinet's START button.

Executing by selecting EXIT proceeds to NAOMI Test Mode.

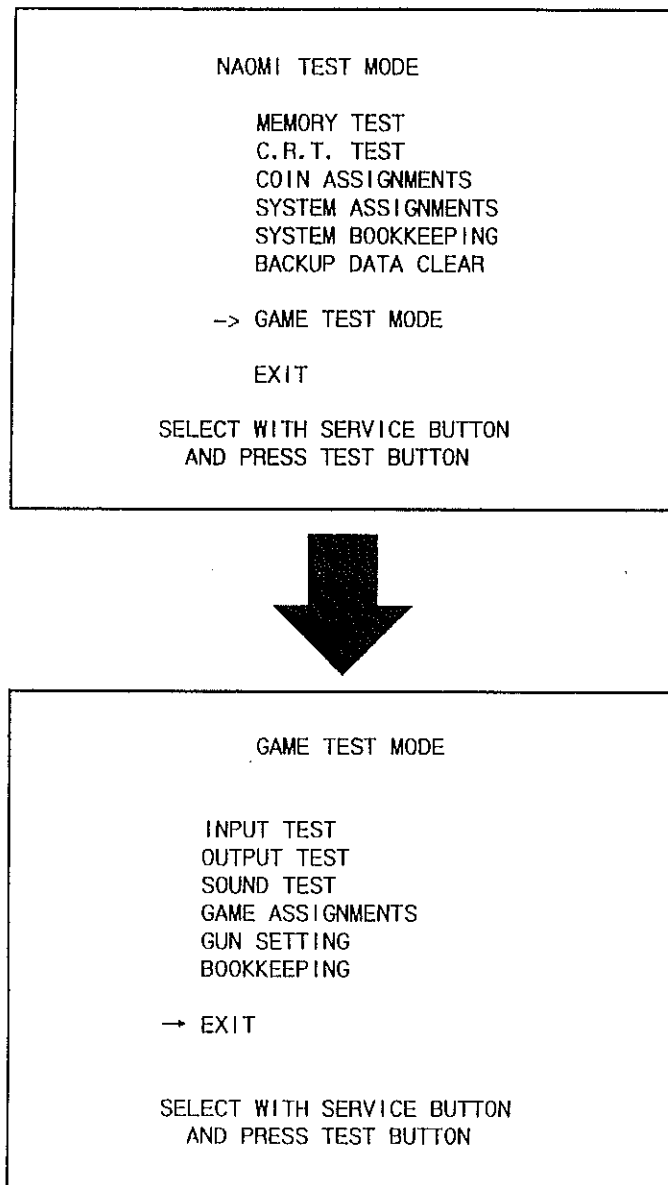

FIG. 9.3 a Test Menu, GAME TEST MODE

② INPUT TEST

INPUT TEST		
	PLAYER1	PLAYER2
START	OFF	OFF
TRIGGER	OFF	OFF
GUN-X	00	00
GUN-Y	00	00
SCREEN-IN	OUT	OUT

PRESS TEST BUTTON TO EXIT

FIG. 9.3 b INPUT TEST

- **PLAYER 1 START:**
To cause this to be ON, press START button 1.
- **PLAYER 2 START:**
To cause this to be ON, press START button 2.
- **PLAYER 1 TRIGGER:**
To cause this to be ON, press TRIGGER 1.
- **PLAYER 2 TRIGGER:**
To cause this to be ON, press TRIGGER 2.
- **PLAYER 1 GUN-X:**
Displays SIGHT position of GUN 1 in the X direction.
- **PLAYER 2 GUN-X:**
Displays SIGHT position of GUN 2 in the X direction.
- **PLAYER 1 GUN-Y:**
Displays SIGHT position of GUN 1 in the Y direction.
- **PLAYER 2 GUN-Y:**
Displays SIGHT position of GUN 2 in the Y direction.
- **PLAYER 1 SCREEN-IN:**
GUN 1 points in-screen sight.
- **PLAYER 2 SCREEN-IN:**
GUN 2 points in-screen sight.

Press the TEST button to return to the TEST MENU.

③ OUTPUT TEST

OUTPUT TEST		
START1 LAMP		OFF
START2 LAMP		OFF

→ EXIT

SELECT WITH SERVICE BUTTON
AND PRESS TEST BUTTON

FIG. 9.3 c OUTPUT TEST

- **START 1 LAMP:**
To cause this to be ON, select START 1 LAMP and press either TEST button or START button 1. The Cabinet's START button 1 lights up.
- **START 2 LAMP:**
To cause this to be ON, select START 2 LAMP and press either TEST button or START button 2. The Cabinet's START button 2 lights up.
- **EXIT:**
Returns to the TEST MENU.

④ SOUND TEST

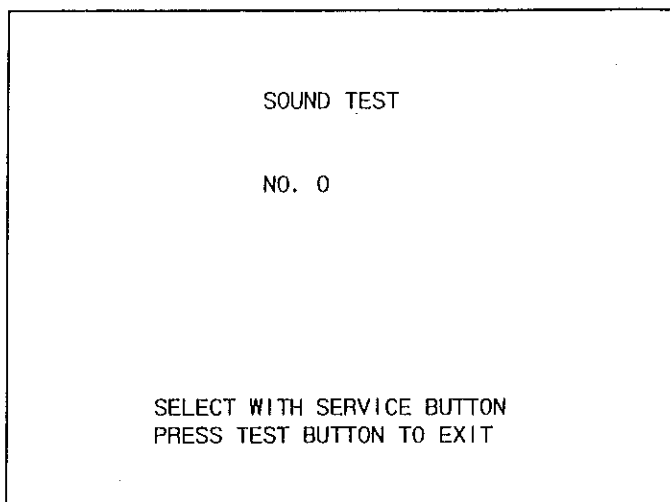

Press the SERVICE button to increase the number sequentially so as to emit the next sound. Press the TEST button to return to TEST MENU.

FIG. 9.3 d SOUND TEST

⑤ GAME ASSIGNMENTS

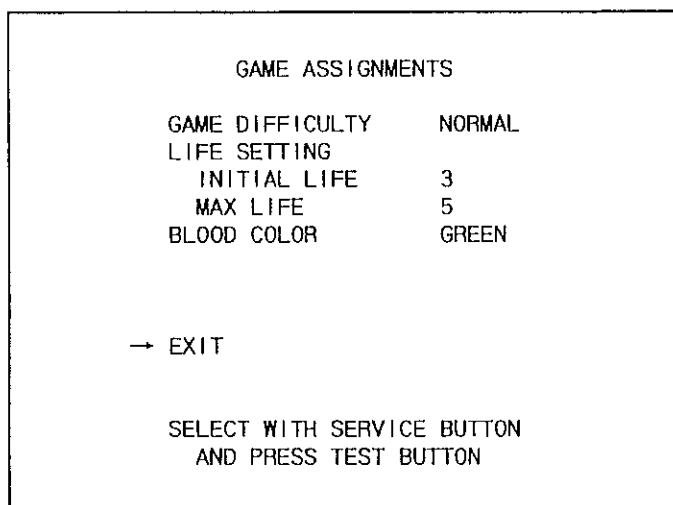

● GAME DIFFICULTY:

VERY EASY →
 MEDIUM EASY →
 NORMAL →
 MEDIUM HARD →
 VERY HARD

Game Difficulty Level varies sequentially in order as above.

FIG. 9.3 e GAME ASSIGNMENTS

● LIFE SETTING:

INITIAL LIFE and MAX. LIFE are interlocked in the following 12 combination sets.

INITIAL LIFE	1	2	3	1	2	3	4	1	2	3	4	5
MAX LIFE	3	3	3	4	4	4	4	5	5	5	5	5

The SOUND OUTPUT during ADVERTISE can be set in the NAOMI Test Mode.

● BLOOD COLOR:

Depending on the destination, this can not be set.
 Set BLOOD COLOR to GREEN or RED.

⑥ GUN SETTING

Selecting GUN SETTING causes the following screen shown at the top to appear. This allows the controller sighting to be adjusted. Periodically check the sighting adjustment status on this screen.

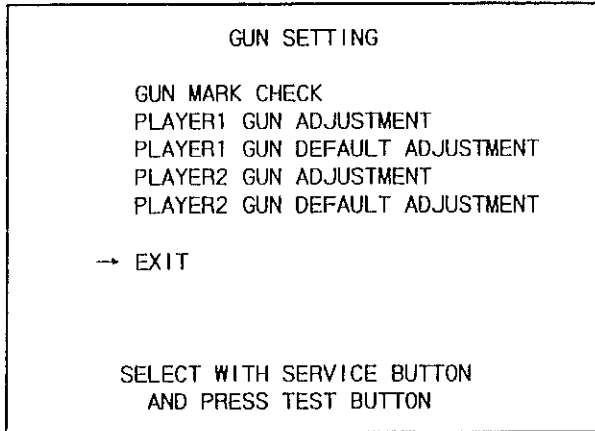

FIG. 9. 3 d SIGHTING ADJUSTMENT MENU

The screen shown at the left is the sighting adjustment menu mode. Press the SERVICE BUTTON to bring the (->) arrow to the desired adjustment item to select.

Press the TEST BUTTON to cause the following sighting check screen and sighting adjustment screen to appear. There are 2 types of adjustments, i. e., one for 1P side and the other for 2P side. Adjustments for both 1P and 2P can not be made on the same screen.

To return to the menu, bring the arrow to EXIT and press the TEST BUTTON (FIG. 9. 3 a).

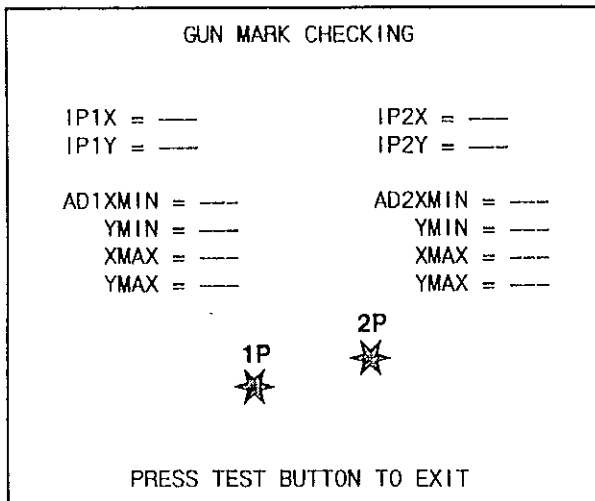

FIG. 9. 3 e SIGHTING CHECK

Selecting GUN MARK CHECK causes the screen at the left to appear. Point the controller at this screen to have an impact mark appear on the screen. The position of the mark shows the impact point shot by the controller. A red impact mark applies to the 1P side and a blue one to the 2P side. Perform sighting check on this screen.

Press the TEST BUTTON to return to the above sighting adjustment menu screen.

 -> IMPACT MARK

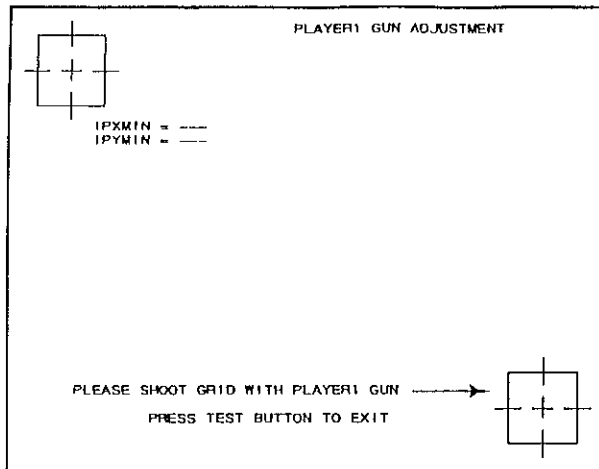

FIG. 9. 3 f SIGHTING ADJUSTMENT

Selecting PLAYER 1 GUN ADJUSTMENT causes the screen shown at the left to be displayed. 1P side sighting adjustment can be made on this screen. If the TEST BUTTON is pressed, the sighting adjustment menu returns to the screen without performing anything.

Adjustment procedure: First shoot at the center of the grid (the square mark at the upper left portion of the screen). This causes another grid to appear at the lower right portion of the screen. Shoot at this grid also. (To be continued.)

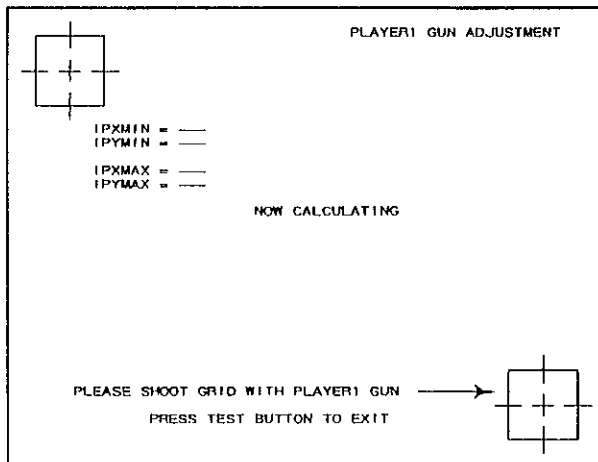

FIG. 9. 3 g SIGHTING ADJUSTMENT

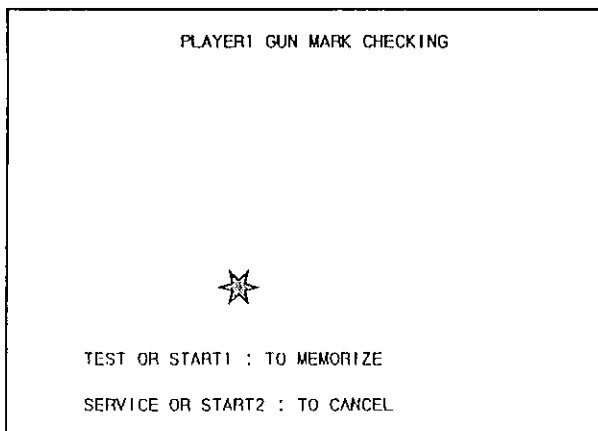

FIG. 9. 3 h SIGHTING ADJUSTMENT SELECTION

Shooting the 2 Grid points displays "NOW CALCULATING" on the center of screen to allow sighting to be adjusted. Next, the gun mark checking screen shown left appears. When the Controller is pointed to the screen, the gun mark is shown on the screen. The mark position shows the gunshot. If this adjustment is satisfactory, press either the Test button or 1P side START button. When readjusting, press either the Service button or 2P side START button.

 → IMPACT MARK

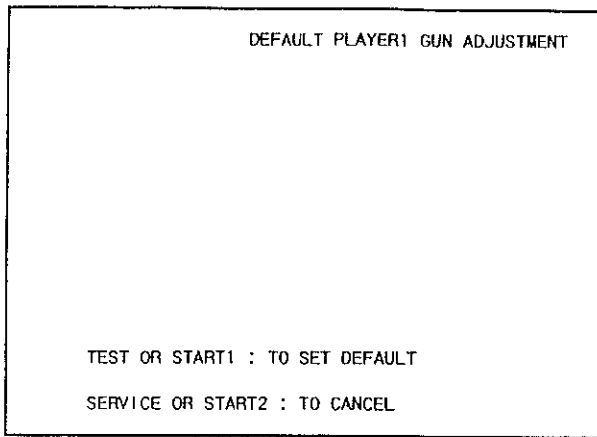

FIG. 9.3 i SIGHTING ADJUSTMENT

Choosing PLAYER 1 GUN DEFAULT ADJUSTMENT causes the screen shown at the left to be displayed. The sighting is reset to the initial setting made at the time of shipment from the factory.

However, due to some changes in the unit's environment and cabinet after shipment, sighting may not be always accurate. To reset to the initial setting, press the TEST BUTTON or 1P side start button. To return to the sighting adjustment menu without doing anything, press the SERVICE BUTTON or 2P side start button.

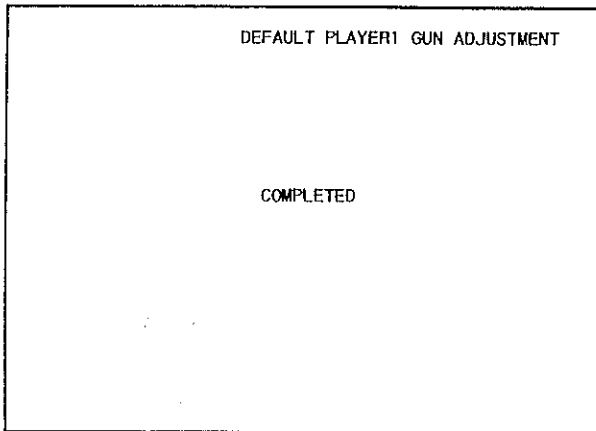

FIG. 9.3 j SIGHTING ADJUSTMENT

The 2P side SIGHT setting is performed in the "PLAYER 2 GUN ADJUSTMENT," and "PLAYER 2 GUN DEFAULT ADJUSTMENT." The setting method is the same as in the 1P side.

TABLE OF CONTENTS

BEFORE USING THE PRODUCT, BE SURE TO READ THE FOLLOWING:

TABLE OF CONTENTS

INTRODUCTION OF THE OWNER'S MANUAL

1. HANDLING PRECAUTIONS	1 ~ 2
2. PRECAUTIONS CONCERNING INSTALLATION LOCATION	3 ~ 4
3. OPERATION	5 ~ 6
4. NAME OF PARTS	7
5. ACCESSORIES	8 ~ 10
6. ASSEMBLING AND PRECAUTIONS	11 ~ 18
7. PRECAUTIONS TO BE HEEDED WHEN MOVING THE MACHINE	19
8. CONTENTS OF GAME	20 ~ 22
9. EXPLANATION OF TEST AND DATA DISPLAY	23 ~ 41
9-1 SWITCH UNIT AND COIN METER	24
9-2 NAOMI TEST MODE	25 ~ 34
9-3 GAME TEST MODE	35 ~ 41
10. CONTROLLER	42 ~ 43
11. COIN SELECTOR	44
12. MONITOR	45 ~ 48
12-1 CAUTIONS AND WARNINGS CONCERNING THE SAFETY FOR HANDLING THE MONITORS	45 ~ 46
12-2 CAUTIONS TO BE HEEDED WHEN CLEANING THE CRT SURFACES	46
12-3 ADJUSTMENT METHOD	47 ~ 48
13. REPLACING THE FLUORESCENT LAMP, AND LAMPS	49 ~ 50
13-1 REPLACING THE FLUORESCENT LAMP	49
13-2 REPLACING THE LAMP	50
14. PERIODIC INSPECTION TABLE	51 ~ 52
15. TROUBLESHOOTING	53 ~ 56
16. GAME BOARD	57 ~ 58
16-1 REMOVING THE BOARD	57
16-2 COMPOSITION OF GAME BOARD	58
17. DESIGN RELATED PARTS	59
18. PARTS LIST	60 ~ 81
19. WIRE COLOR CODE TABLE	82
20. WIRING DIAGRAM	83 ~ 84

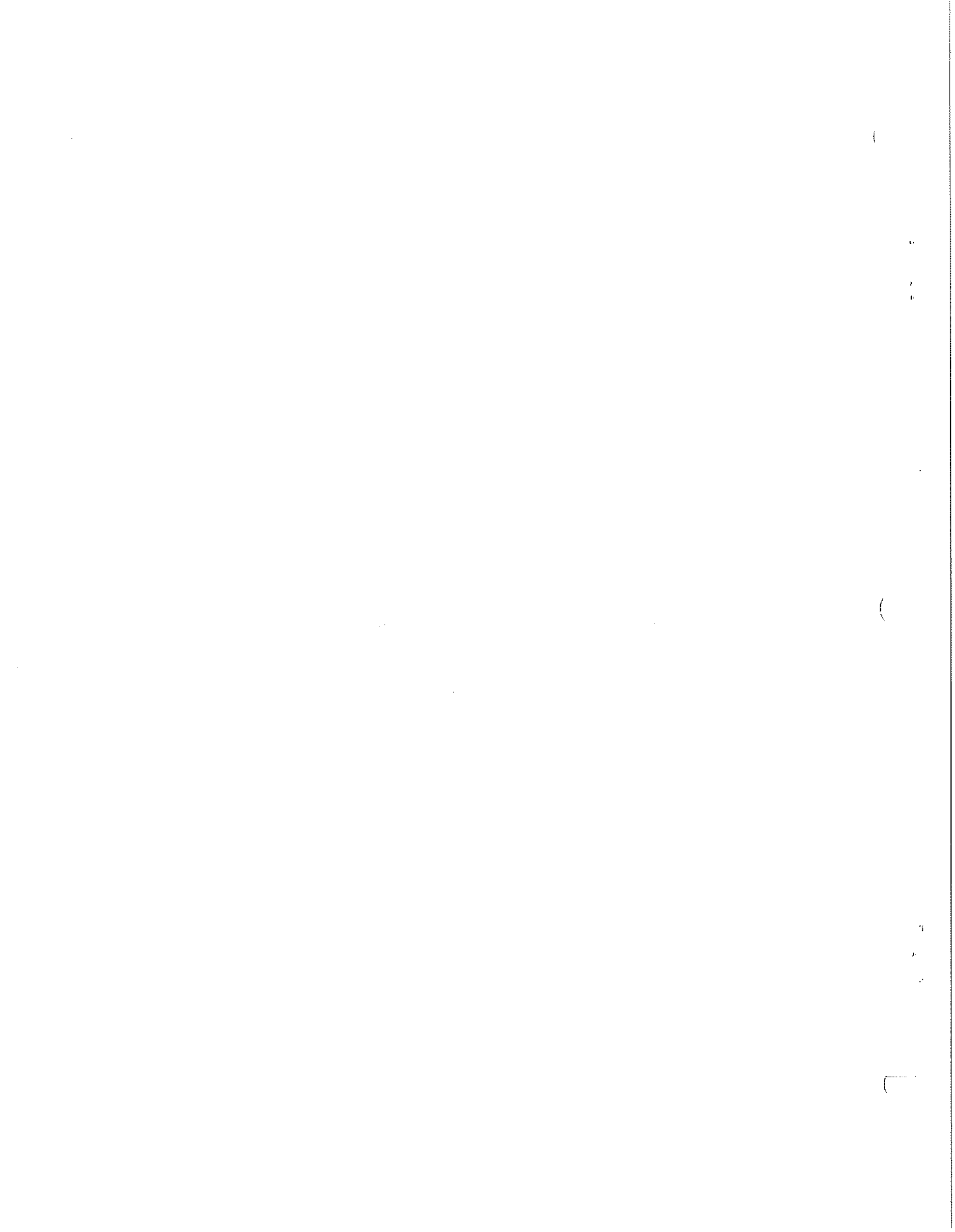

SPECIFICATIONS

Installation space	: 800 mm (W) × 890 mm (D) (31.5 in. × 35.0 in.)
Height	: 2,072 mm (81.6 in.)
Weight	: 195 kg. (429.9 lbs.)
Power, maximum current	: 218 W 2.53 A (AC 110V 50 Hz AREA) 213 W 2.46 A (AC 110V 60 Hz AREA) 215 W 2.31 A (AC 120V 60 Hz AREA) 220 W 1.28 A (AC 220V 50 Hz AREA) 210 W 1.22 A (AC 220V 60 Hz AREA) 220 W 1.23 A (AC 230V 50 Hz AREA) 213 W 1.18 A (AC 230V 60 Hz AREA) 221 W 1.18 A (AC 240V 50 Hz AREA) 209 W 1.12 A (AC 240V 60 Hz AREA)
MONITOR	: 29 INCH COLOR MONITOR

INTRODUCTION OF THE OWNER'S MANUAL

This Owner's Manual is intended to provide detailed descriptions together with all the necessary information covering the general operation of electronic assemblies, electromechanicals, servicing control, spare parts, etc. as regards the product, **THE HOUSE OF THE DEAD 2 U/R TYPE.**

This manual is intended for the owners, personnel and managers in charge of operation of the product. Operate the product after carefully reading and sufficiently understanding the instructions. If the product fails to function satisfactorily, non-technical personnel should under no circumstances touch the internal system. Please contact where the product was purchased from.

SEGA ENTERPRISES, INC. (U.S.A.)/CUSTOMER SERVICE
45133 Industrial Drive, Fremont, California 94538, U.S.A.

Phone : (415) 802-3100

Fax : (415) 802-1754

DEFINITION OF LOCATION MAINTENANCE MAN AND SERVICEMAN



WARNING!

Non-technical personnel who do not have technical knowledge and expertise should refrain from performing such work that this manual requires the location's maintenance man or a serviceman to carry out, or work which is not explained in this manual. Failing to comply with this instruction can cause a severe accident such as electric shock.

Ensure that parts replacement, servicing & inspections, and troubleshooting are performed by the location's maintenance man or the serviceman. It is instructed herein that particularly hazardous work should be performed by the serviceman who has technical expertise and knowledge.

The location's maintenance man and serviceman are herein defined as follows:

"Location's Maintenance Man" :

Those who have experience in the maintenance of amusement equipment and vending machines, etc., and also participate in the servicing and control of the equipment through such routine work as equipment assembly and installation, servicing and inspections, replacement of units and consumables, etc. within the Amusement Facilities and or locations under the management of the Owner and Owner's Operators of the product.

Activities of Location's Maintenance Man :

Assembly & installation, servicing & inspections, and replacement of units & consumables as regards amusement equipment, vending machines, etc.

Serviceman :

Those who participate in the designing, manufacturing, inspections and maintenance service of the equipment at an amusement equipment manufacturer.

Those who have technical expertise equivalent to that of technical high school graduates as regards electricity, electronics and or mechanical engineering, and daily take part in the servicing & control and repair of amusement equipment.

Serviceman's Activities :

Assembly & installation and repair & adjustments of electrical, electronic and mechanical parts of amusement equipment and vending machines.

1. HANDLING PRECAUTIONS

When installing or inspecting the machine, be very careful of the following points and pay attention to ensure that the player can enjoy the game safely.

Non-compliance with the following points or inappropriate handling running counter to the cautionary matters herein stated can cause personal injury or damage to the machine.



WARNING!

- Before performing work, be sure to turn power off. Performing the work without turning power off can cause an electric shock or short circuit. In the case work should be performed in the status of power on, this manual always states to that effect.
- To avoid electric shock or short circuit, do not plug in or unplug quickly.
- To avoid electric shock, do not plug in or unplug with a wet hand.
- Do not expose Power Cords and Earth Wires on the surface, (floor, passage, etc.). If exposed, the Power Cords and Earth Wires are susceptible to damage. Damaged cords and wires can cause electric shock or short circuit.
- To avoid causing a fire or electric shock, do not put things on or damage Power Cords.
- When or after installing the product, do not unnecessarily pull the power cord. If damaged, the power cord can cause a fire or electric shock.
- In case the power cord is damaged, ask for replacement through where the product was purchased from or the office herein stated. Using the cord as is damaged can cause fire, electric shock or leakage.
- Be sure to perform grounding appropriately. Inappropriate grounding can cause an electric shock.
- Be sure to use fuses meeting specified rating. Using fuses exceeding the specified rating can cause a fire or electric shock.
- Completely make connector connections for IC BD and others. Insufficient insertion can cause an electric shock.
- To avoid causing a fire or electric shock, do not make Specification changes by removing, converting and making additions unless otherwise designated by SEGA.
- Be sure to perform periodic maintenance inspections herein stated.



IMPORTANT!

- For the IC board circuit inspections, only the logic tester is allowed. The use of a multiple-purpose tester is not permitted, so be careful in this regard.
- When cleaning the CRT surfaces, use a soft, dry cloth. Do not apply chemicals such as thinner, benzine, etc.
- The electronic parts on the IC Board could be damaged due to human body's static electricity. Before performing IC Board related work, be sure to discharge physically accumulated statics by touching grounded metallic surfaces, etc.

CONCERNING THE STICKER DISPLAY

SEGA product has Stickers describing the product manufacture No. (Serial No.) and Electrical Specifications. Also it has a Sticker describing where to contact for repair and for purchasing parts. When inquiring about or asking for repair, mention the Serial No. and Name of Machine indicated on the Sticker. The Serial No. indicates the product register. Identical machines could have different parts depending on the date of production. Also, improvements and modifications might have been made after the publication of this Manual. In order to meet the above situations, mention the Serial No. when contacting the applicable places.

CONCERNING WARNING DISPLAYS

SEGA product has warning displays on Stickers. Labels and or printed instructions adhered / attached to or incorporated in the places where a potentially hazardous situation can arise. The warning displays are intended for accident prevention for the customers and for avoiding hazardous situation relating to maintenance and servicing work. There are some portions in the Cabinet, which are subject to high tension voltage, etc. where accidents can be caused merely by touching. When performing the servicing work, be very careful of the warning displays. Especially, any complex repair and replacement work not mentioned herein, should be performed by those technical personnel who have knowledge of electricity and technical expertise. For the prevention of accidents, caution any customer whose act runs counter to the warnings, as to the effect that he must stop the act.

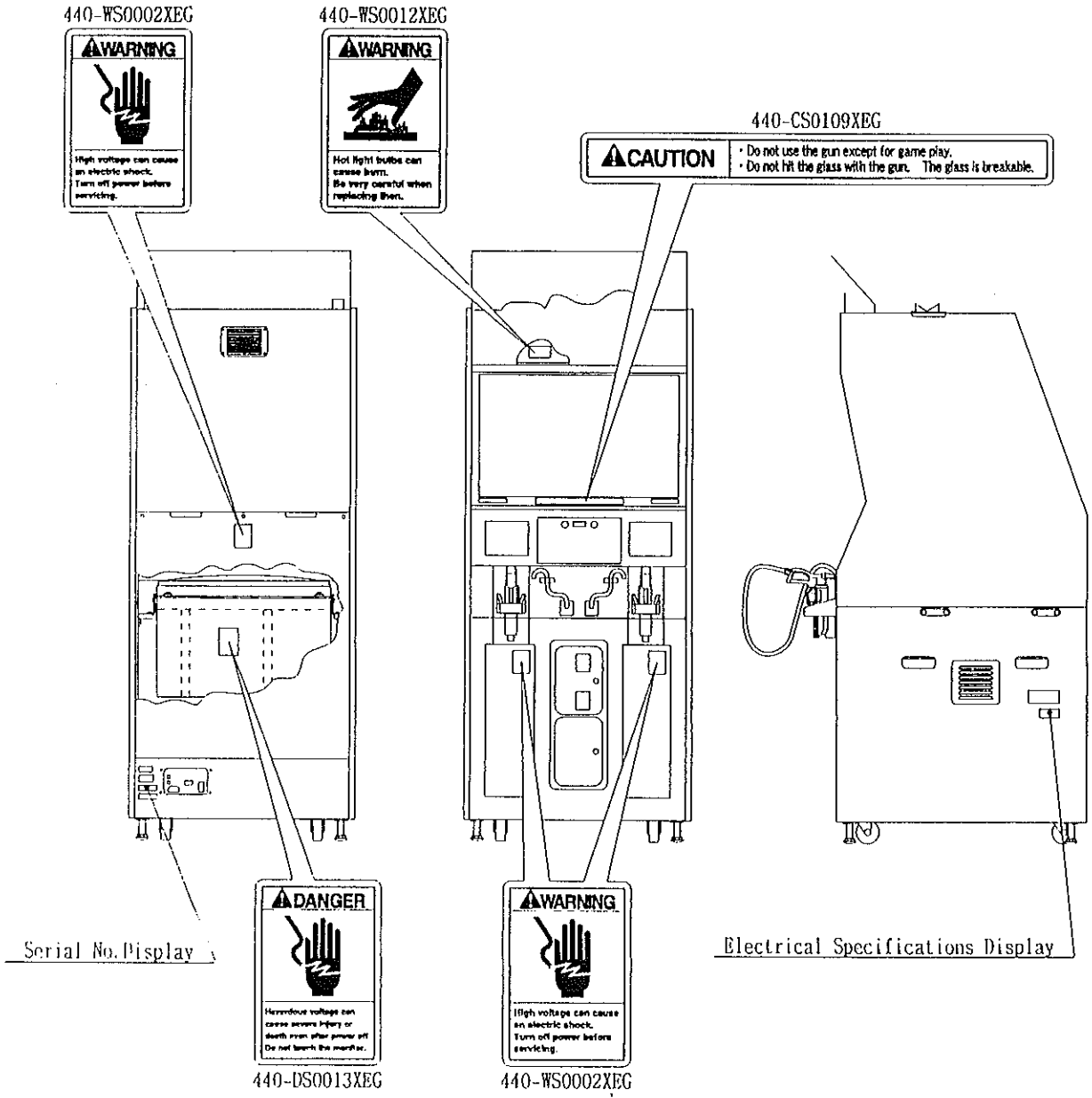

2. PRECAUTIONS CONCERNING INSTALLATION LOCATION



This product is an indoor game machine. Do not install it outside. Even indoors, avoid installing in places mentioned below so as not to cause a fire, electric shock, injury and or malfunctioning.

- Places subject to rain or water leakage, or places subject to high humidity in the proximity of an indoor swimming pool and or shower, etc.
- Places subject to direct sunlight, or places subject to high temperatures in the proximity of heating units, etc.
- Places filled with inflammable gas or vicinity of highly inflammable/volatile chemicals or hazardous matter.
- Dusty places.
- Sloped surfaces.
- Places subject to any type of violent impact.
- Vicinity of anti-disaster facilities such as fire exits and fire extinguishers.
- The operating (ambient) temperature range is from 5°C to 40°C. Only in the case a projector is employed, the temperature range is from 5°C to 30°C.

LIMITATIONS OF USAGE REQUIREMENTS



- Be sure to check the Electrical Specifications. Ensure that this product is compatible with the location's power supply, voltage and frequency requirements. A plate describing Electrical Specifications is attached to the product. Non-compliance with the Electric Specifications can cause a fire and electric shock.
- This product requires the Breaker and Earth Mechanisms as part of the location facilities. Using them in a manner not independent can cause a fire and electric shock.
- Ensure that the indoor wiring for the power supply is rated at 7A or higher (AC single phase 100~120V area), and 3A or higher (AC 220~240V area). Non-compliance with the Electrical Specifications can cause a fire and electric shock.
- Be sure to independently use the power supply equipped with the Earth Leakage Breaker. Using a power supply without the Earth Leakage Breaker can cause an outbreak of fire when earth leakage occurs.
- Putting many loads on one electrical outlet can cause generation of heat and a fire resulting from overload.
- When using an extension cord, ensure that the cord is rated at 7A or higher (AC 100~120V area) and 3A or higher (AC 220~240V area). Using a cord rated lower than the specified rating can cause a fire and electric shock.

Electric current consumption

MAX.	2.53A	(AC 110V	50 Hz)
MAX.	2.46A	(AC 110V	60 Hz)
MAX.	2.31A	(AC 120V	60 Hz)
MAX.	1.28A	(AC 220V	50 Hz)
MAX.	1.22A	(AC 220V	60 Hz)
MAX.	1.23A	(AC 220V	50 Hz)
MAX.	1.18A	(AC 220V	60 Hz)
MAX.	1.18A	(AC 240V	50 Hz)
MAX.	1.12A	(AC 240V	60 Hz)



IMPORTANT!

- For transporting the machine into the location's building, the minimum necessary dimensions of the opening (of doors, etc.) are 0.9m(W) and 2m(H).
- For the operation of this machine, secure a minimum area of 1.2m (W) × 1.6m (D). For ventilation, provide an approximately 10cm. space between the rear part of the cabinet and the wall.

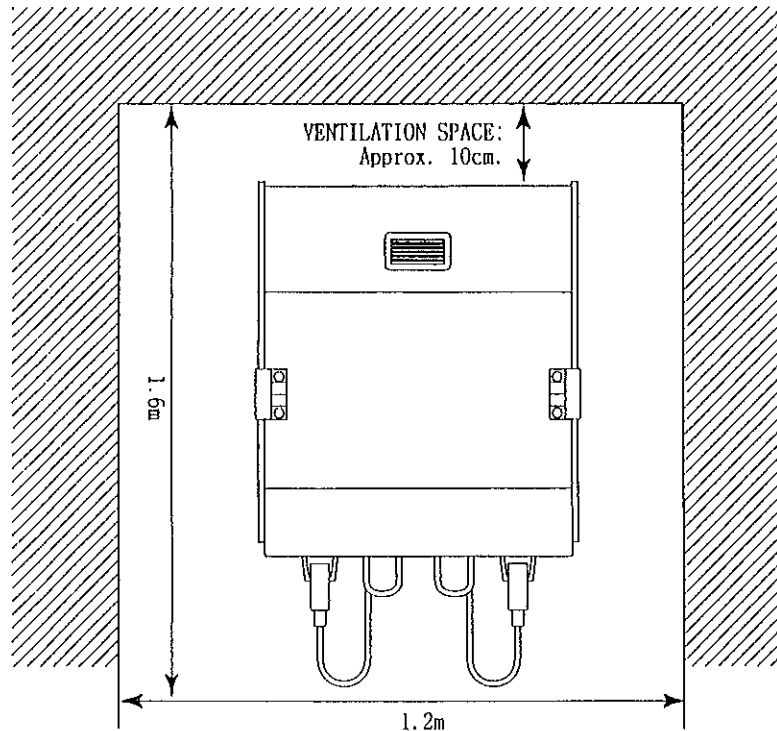

FIG. 2

3. OPERATION

For the safe operation of the product, be sure to observe the following points before starting and during operation.

PRECAUTIONS TO BE HEEDED FOR OPERATION



In order to avoid accidents, check the following before starting the operation:

- Check if all of the adjusters are in contact with the surface. If they are not, the Cabinet can move and cause an accident.

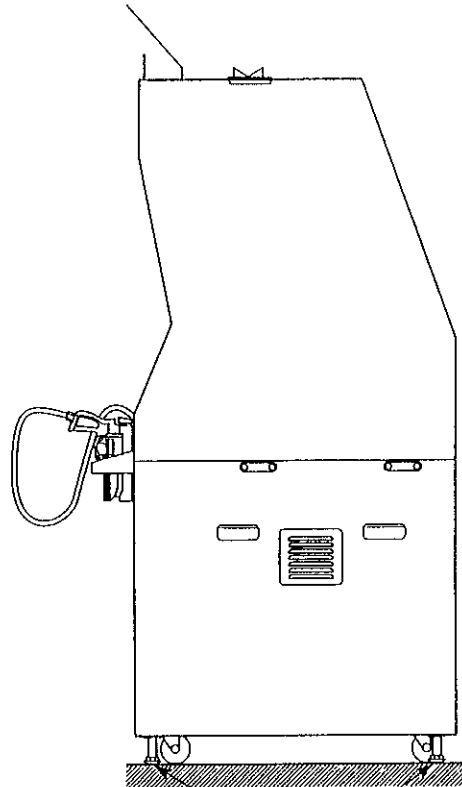

Ensure that all of the Adjusters are in contact with the floor.

- Do not put any heavy item on this product. Placing any heavy item on the product can cause a falling down accident or parts damage.
- Do not climb on the product. Climbing on the product can cause falling down accidents. To check the top portion of the product, use a step.
- To avoid electric shock, check to see if door & cover parts are damaged or omitted.
- To avoid electric shock, short circuit and or parts damage, do not put the following items on or in the periphery of the product.
Flower vases, flowerpots, cups, water tanks, cosmetics, and receptacles/containers/vessels containing chemicals and water.



To avoid injury, be sure to provide sufficient space by considering the potentially crowded situation at the installation location. Insufficient installation space can cause the player to come into contact with or hit the others and result in injury or trouble.

PRECAUTIONS TO BE HEEDED DURING OPERATION (PAYING ATTENTION TO CUSTOMERS)

To avoid injury and trouble, be sure to constantly give careful attention to the behavior and manner of the visitors and players.



- To avoid electric shock and short circuit, do not allow customers to put hands and fingers or extraneous matter in the openings of the product or small openings in or around the doors.
- To avoid falling down and injury resulting from falling down, immediately stop the customer's leaning against or climbing on the product, etc.
- To avoid electric shock and short circuit, do not allow the customers to unplug the power plug without a justifiable reason.
- To avoid injury resulting from falling down, and electric shock due to spilled drinks, instruct the player not to place heavy items or drinks on the product.



Immediately stop such violent acts as hitting and kicking the product. Such violent acts can cause parts damage or falling down, resulting in injury due to fragments and falling down.

4. NAME OF PARTS

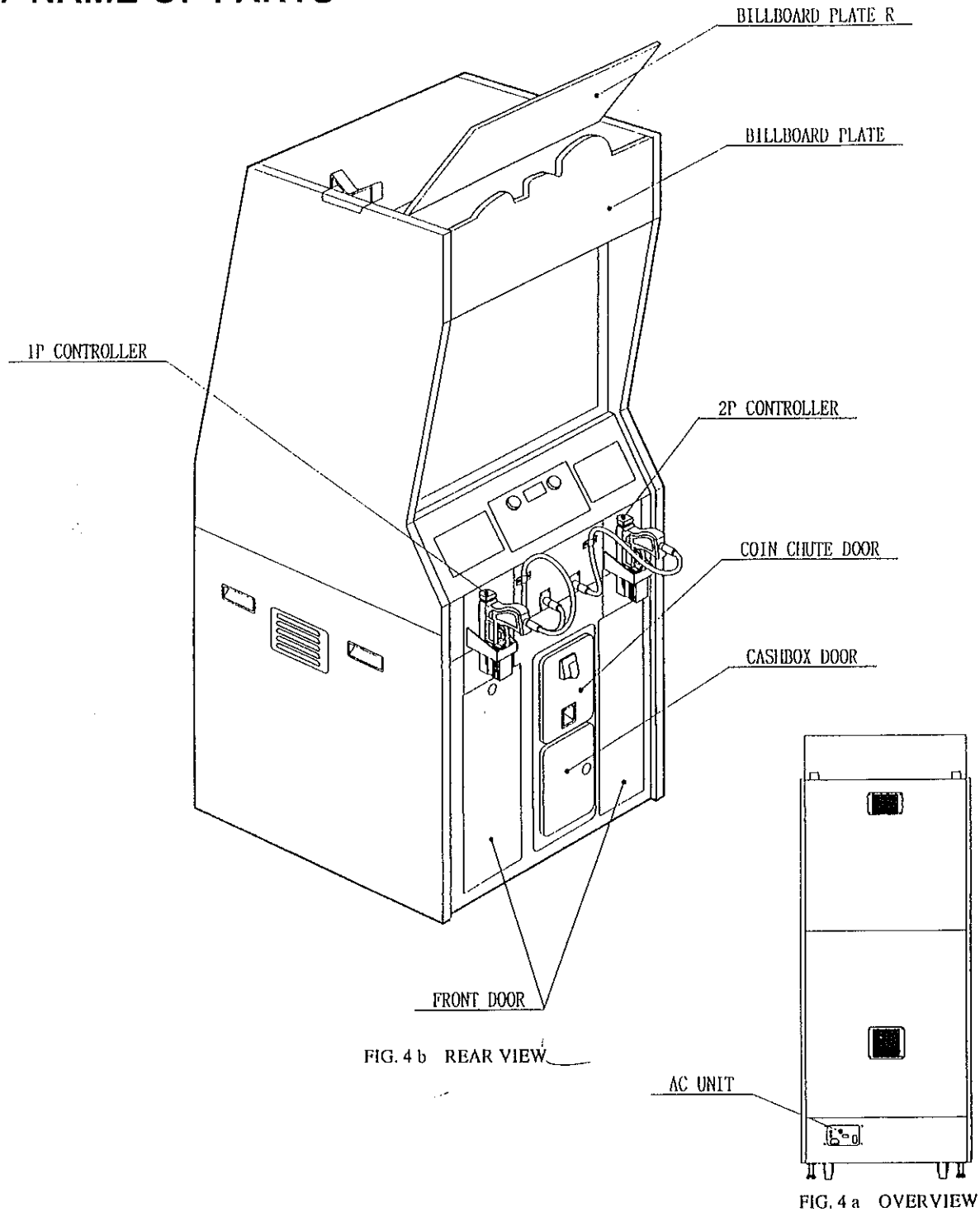

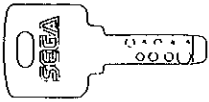
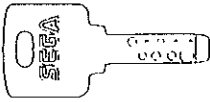
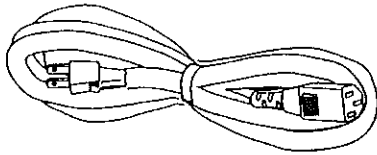
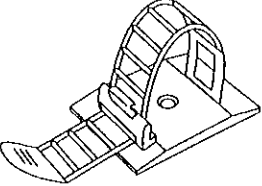
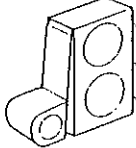

TABLE 4

	Width	Length	Height (mm.)	Weight (kg.)
CABINET	800	890	1,900	195
When assembled	800	890	2,072	195

5. ACCESSORIES

When transporting the machine, make sure that the following parts are supplied.

TABLE 5 ACCESSORIES

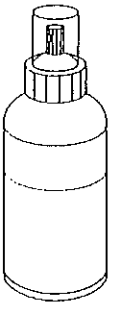
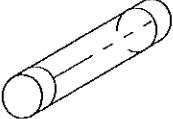
<p>DESCRIPTION OWNERS MANUAL Part No. (Qty.) 420-6428-04 (1) Note Figures If Part No. has no description, the Number has not been registered or can not be registered. Such a part may not be obtainable even if the customer desires to purchase it. Therefore, ensure that the part is in safekeeping with you.</p>	<p>KEY MASTER 220-5576 (2) For opening/closing the doors</p>	<p>KEY (2) For the CASHBOX DOOR</p>
		
<p>AC Cable (Power Cord) 600-6724 (1) AC 110V AREA 600-6729 (1) AC 220~240V AREA Used for installation, see [3] of Section 6.</p>	<p>CORD CLAMP 280-5009-01 (1) Used for installation, see [3] of Section 6.</p>	
		
<p>SW MICRO TYPE 509-5080 (1) Spare, see Section 10.</p>	<p>LAMP WEDGE 14V 2.7W 390-6605 (2) Spare, see Section 13.</p>	
		
<p>GLASS CLEANER 090-0174 (1) Used for cleaning the Front Glass of the Projector. See Section 14.</p>	<p>FUSE 5000mA 125V 514-5036-5000 (1) Spare, see Section 15.</p>	
		

WIRE
HOD-60040 (1)
Used for the prevention of
Sight Sensor jamming
(see next page).

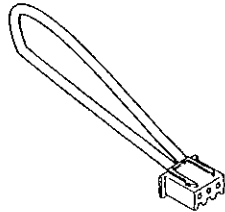

CARTON BOX
601-8928 (1)
Used for transporting the
Game Board.
Refer to the following.

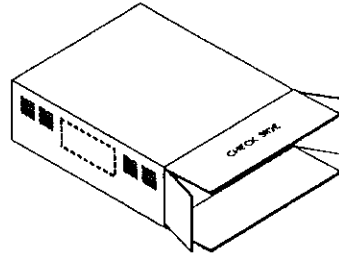

HOW TO USE THE CARTON BOX



- When asking for the replacement or repair of the product's Game Board, be sure to put the Game Board together with the Shield Case in a Carton Box. Otherwise, the request is not acceptable.
- Put the Shield Case in the Carton Box by paying attention to the correct direction as per the following instructions and as shown by the instructions printed on the Carton Box. Handling in an erroneous manner can damage the Game Board.

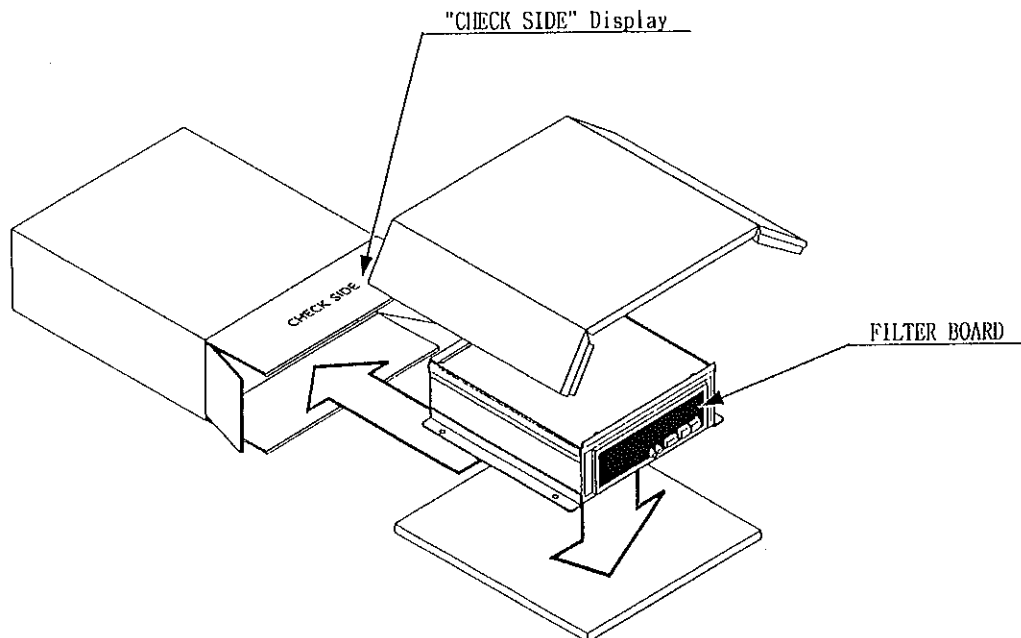

Wrap the Shield Case with the packing material and put it in the Carton Box as shown. Putting it upside down or packing otherwise in the manner not shown can damage the Game Board and parts.

APPLICATION OF ACCESSORY WIRE



- In order to prevent electric shock and short circuit hazards, be sure to turn power off before performing work.
- Be careful so as not to damage wirings. Damaged wiring can cause fire, electric shock and short circuit hazards.
- Do not expose the IC BD, etc. without a good reason. Failure to observe this can cause electric shock hazard or malfunctioning.
- Work should be performed by the Location's Maintenance Man or technical personnel. Performing work by those who do not have technical knowledge and expertise can cause electric shock accident or malfunctioning.

The accessory wire is used for the prevention of Sight Sensor jamming. Installing identical game machines side by side can cause malfunctioning resulting from SIGHT sensor jamming. In order to prevent jamming, connect the accessory wire to the connector on the Gun Sensor BD by using the following procedure for one of the two machines installed side by side. When installing more than 3 machines side by side, connect the accessory wire to every other machine(s).

- ① Turn off power for the game machine.
- ② Take out the 2 truss screws and remove Front Door R.
- ③ Disconnect all of the wiring connectors connected to the Unit (ASSY PWR SPLY U/R) inside the Door.
- ④ Take out the 2 Wing Bolts which secure the Unit's wooden Base.
- ⑤ Pull out the Unit.
- ⑥ Connect the Accessory Wire to the on-Unit Gun Sensor BD.

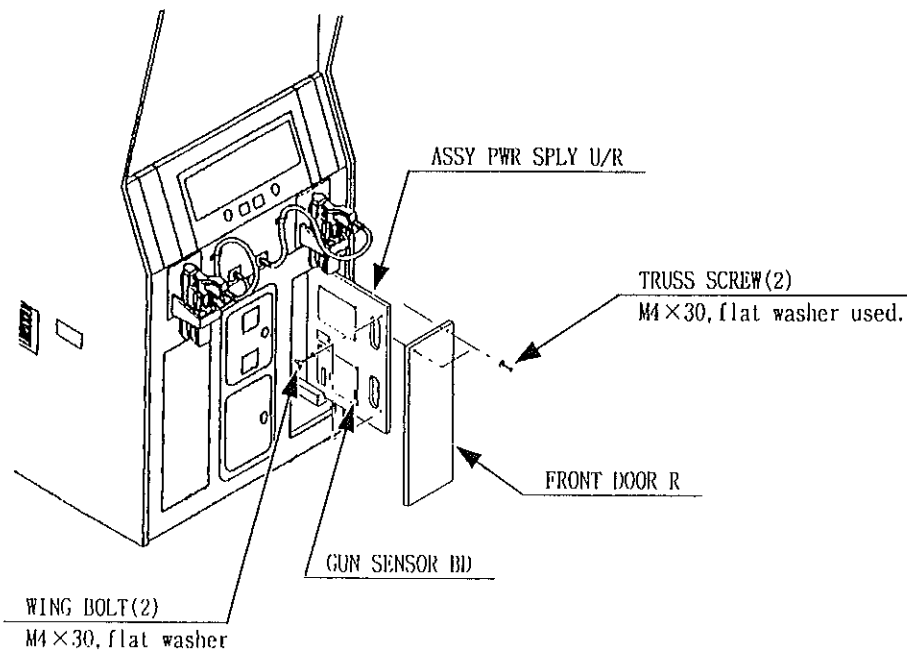

6. ASSEMBLING AND INSTALLATION



- Perform assembly work by following the procedure herein stated. Failing to comply with the instructions can cause electric shock hazard.
- Assembling should be performed as per this manual. Since this is a complex machine, erroneous assembling can cause an electric shock, machine damage and or not functioning as per specified performance.
- When assembling, be sure to use plural persons. Depending on the assembly work, there are some cases in which working by one person alone can cause personal injury or parts damage.

When carrying out the assembly work, follow the procedure in the following 4-item sequence:

- 1 INSTALLATION OF BILLBOARD PLATE AND BILLBOARD PLATE R
- 2 SECURING IN PLACE (ADJUSTER ADJUSTMENT)
- 3 POWER SUPPLY, AND EARTH CONNECTION
- 4 ASSEMBLING CHECK

Note that the master key (accessories) in addition to the tools such as a Phillips type plus screwdriver, wrench for M16 hexagon bolt are required for the assembly work.

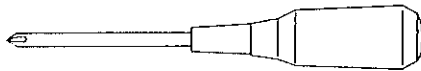

Phillips type screwdriver

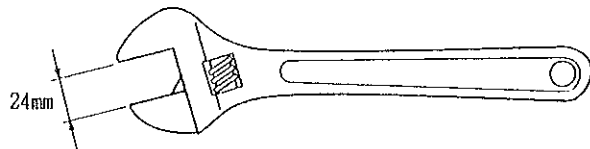

WRENCH (for M16 hexagon bolt)

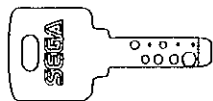

MASTER KEY

1 INSTALLATION OF BILLBOARD PLATE AND BILLBOARD PLATE R



To perform work safely and securely, be sure to prepare a step which is in a secure and stable condition. Performing work without using the step can cause violent falling down accidents.

- ① Take out the 3 Truss screws from the lower part of the Billboard and pull out the Billboard Case towards you.
- ② Apply Billboard Plate R to the rear of Billboard Case with double-sided tape.
- ③ Return the Billboard Case to the original position and secure with the 3 truss screws.
- ④ Take out the 4 truss screws to remove Lamp Cover B.
- ⑤ Insert the Billboard Plate to the Billboard Case and secure Lamp Cover B with the 4 truss screws.

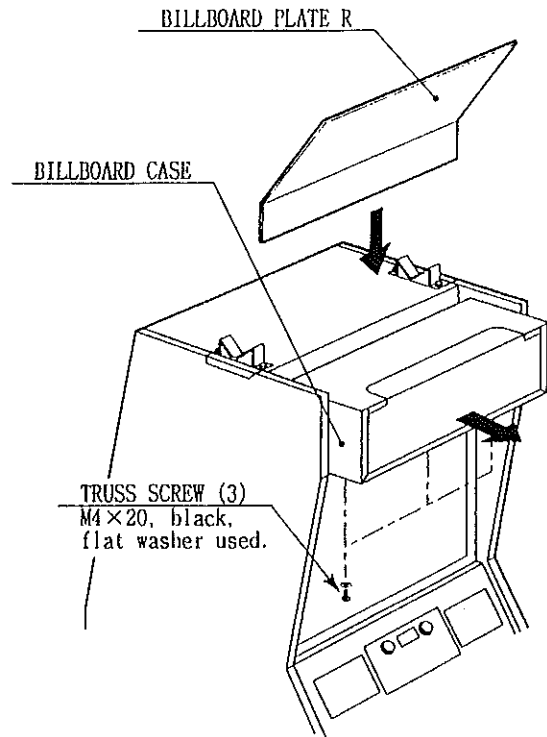
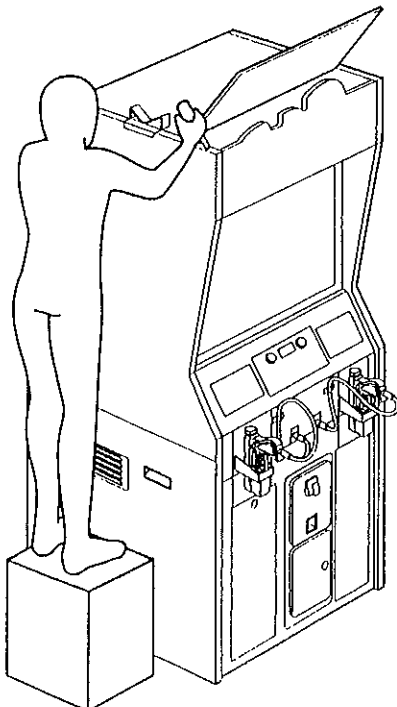

FIG. 6.1 a



When performing work, prepare a step.

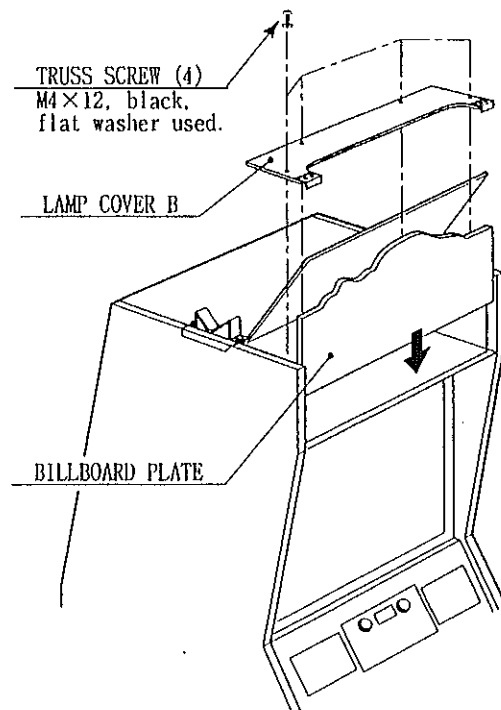

FIG. 6.1 b

2

SECURING IN PLACE (ADJUSTER ADJUSTMENT)



Make sure that all of the adjusters are in contact with the floor. If they are not, the cabinet can move and cause an accident.

This machine has 4 casters and 4 adjusters. When the installation position is determined, cause the adjusters to come into contact with the floor directly, make adjustments in a manner so that the casters will be raised approximately 5mm. from the floor and make sure that the machine position is level.

- ① Move the machine to the installation position.
- ② Cause all of the adjusters to make contact with the floor. By using a wrench, make adjustments in the height of the adjusters to ensure that the machine's position is level.
- ③ After making adjustments, fasten the adjuster nut upward and secure the height of the adjuster.

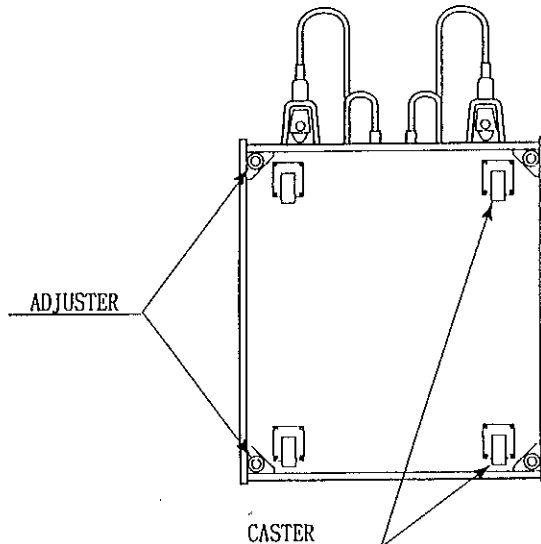

FIG. 6. 2 a BOTTOM VIEW

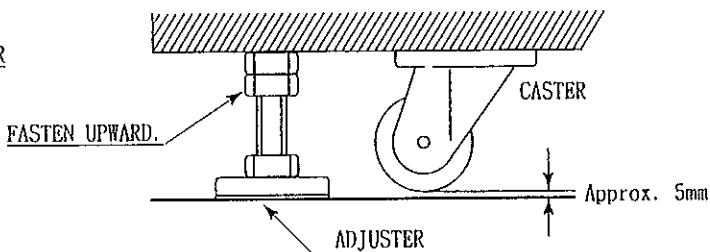
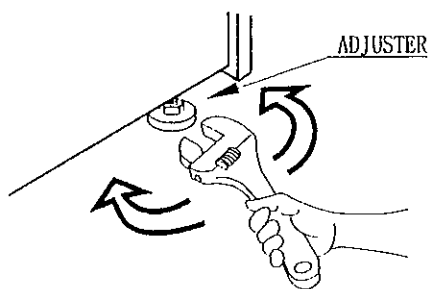

FIG. 6. 2 b ADJUSTER

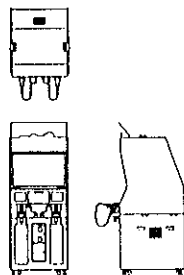

FIG. 6. 2 c
Refer to this Fig. (Scale:1/100)
for the layout of the place of
installation.

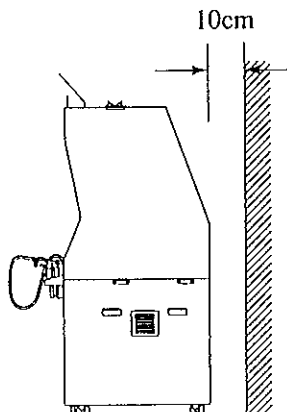

FIG. 6. 2 d
Provide sufficient space so as to allow
for ventilation by the ventilation fan.

3 POWER SUPPLY, AND EARTH CONNECTION



- Be sure to independently use the power supply socket outlet equipped with an Earth Leakage Breaker. Using a power supply without an Earth Leakage Breaker can cause a fire when electric leakage occurs.
- Ensure that the "accurately grounded indoor earth terminal" and the earth wire cable are available (except in the case where a power cord plug with earth is used). This product is equipped with the earth terminal. Connect the earth terminal and the indoor earth terminal with the prepared cable. If the grounding work is not performed appropriately, customers can be subjected to an electric shock, and the product's functioning may not be stable.
- Ensure that the power cord and earth wire are not exposed on the surface (passage, etc.). If exposed, they can be caught and are susceptible to damage. If damaged, the cord and wire can cause electric shock and short circuit hazards. Ensure that the wiring position is not in the customer's passage way or the wiring has protective covering.

- ① The AC Unit is mounted on the rear of the machine. Circuit Protector, and the Inlet which connects the Earth Terminal and the Power Cord.
- ② Ensure that the Main SW is OFF.

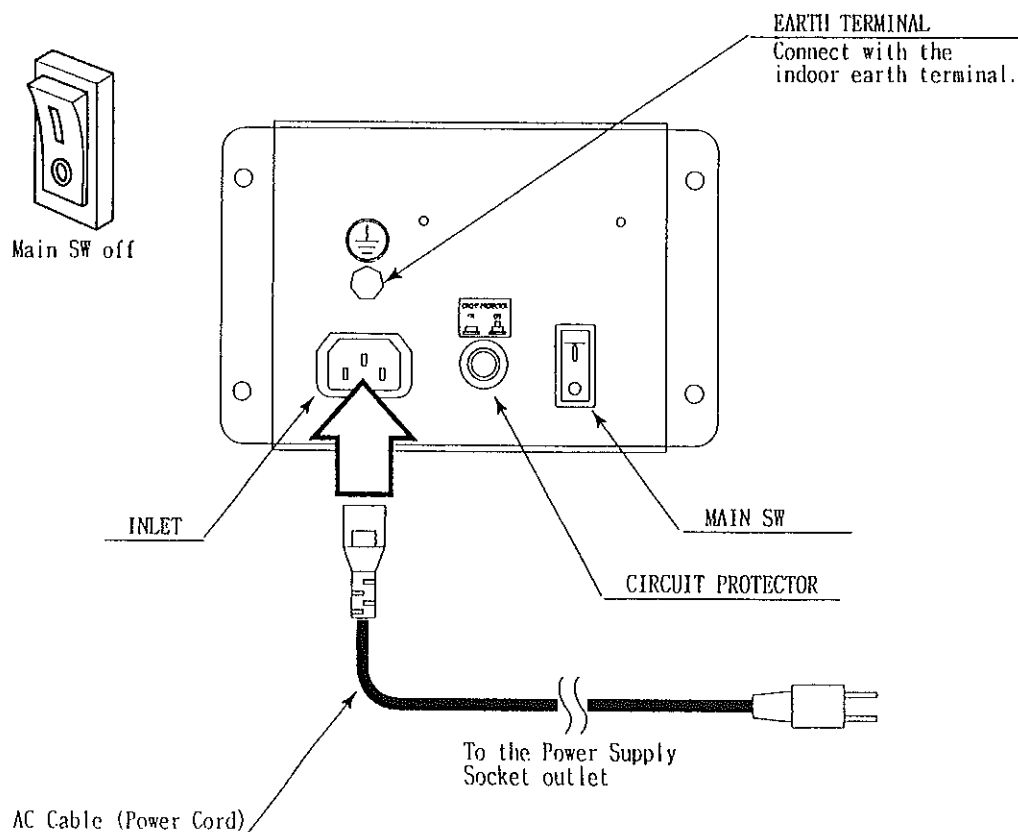

FIG. 6.3 a AC unit

- ③ Connect one end of the earth wire to the AC Unit earth terminal, and the other end to the indoor earth terminal. The AC Unit earth terminal has a Bolt and Nut combination. Take off the Nut, pass the earth wire through the Bolt, and fasten the Nut.

Note that the Earth Wire is incorporated in the Power Cord for the Areas of AC 120V (USA) and AC 220 ~ 240V, and therefore, this procedure is not necessary.

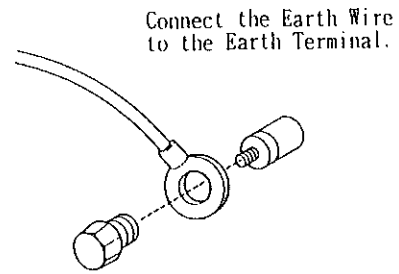

FIG. 6. 3 b Earth Wire Connection

- ④ Firmly insert the power plug into the socket outlet.
Insert the opposite side of Power Cord plug to the AC Unit's connector ("INLET").
- ⑤ Perform wiring for the Power Cord and Earth Wire. Install protective covering for the Power Cord and Earth Wire.

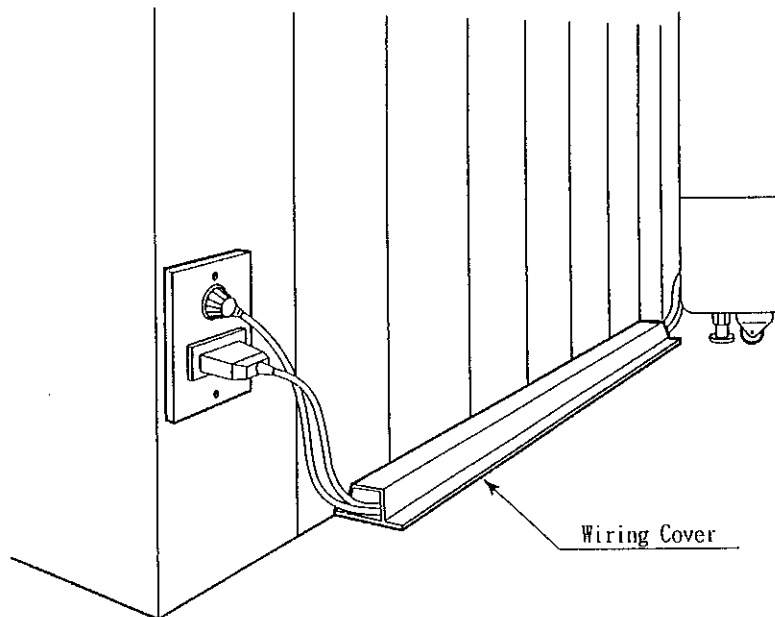
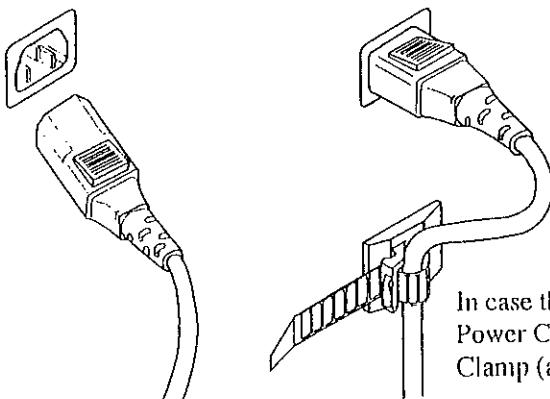

FIG. 6. 3 c Connecting Power Cord and Earth Wire



In case the Power Plug is apt to come out of place, secure the Power Cord to the periphery of the AC Unit with the Cord Clamp (an accessory).

4 ASSEMBLING CHECK

In the TEST MODE, ensure that the assembly has been made correctly and IC BD. is satisfactory (refer to Section 9).

In the test mode, perform the following test:

(1) MEMORY TEST

```
MEMORY TEST MODE

RAM TEST

IC29 GOOD
IC34 GOOD
IC16 GOOD IC18 GOOD
IC20 GOOD IC22 GOOD
IC9 GOOD IC10 GOOD
IC11 GOOD IC12 GOOD

PRESS TEST BUTTON TO CONTINUE
```

Selecting the MEMORY TEST on the test mode menu screen causes the on-board memory to be tested automatically. The game board is satisfactory if the display beside each IC No. shows GOOD.

```
MEMORY TEST MODE

ROM TEST

IC22 (ROM0) GOOD IC1 (ROM1) GOOD
IC2 (ROM2) GOOD IC3 (ROM3) GOOD
IC4 (ROM4) GOOD IC5 (ROM5) GOOD
IC6 (ROM6) GOOD IC7 (ROM7) GOOD
IC8 (ROM8) GOOD IC9 (ROM9) GOOD
IC10 (ROM10) GOOD IC11 (ROM11) GOOD
IC12 (ROM12) GOOD IC13 (ROM13) GOOD
IC14 (ROM14) GOOD IC15 (ROM15) GOOD
IC16 (ROM16) GOOD IC17 (ROM17) GOOD
IC18 (ROM18) GOOD IC19 (ROM19) GOOD
IC20 (ROM20) GOOD

PRESS TEST BUTTON TO EXIT
```

(2) C.R.T. TEST

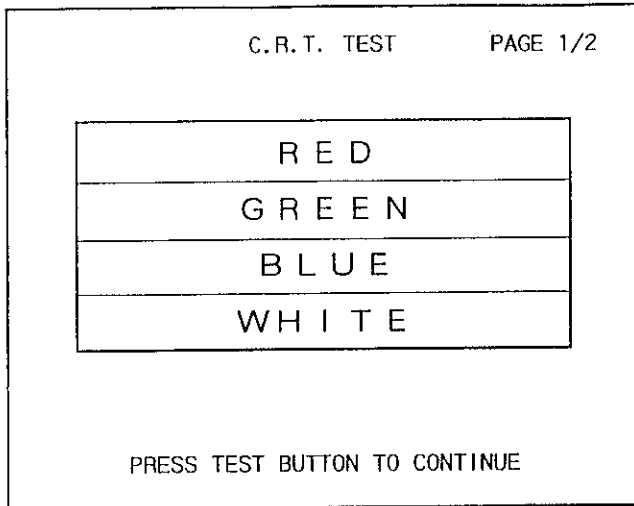

In the TEST mode menu, selecting C.R.T. TEST allows the screen (on which the monitor is tested) to be displayed. Although the monitor adjustments have been made at the time of shipment from the factory, make judgment as to whether an adjustment is needed by watching the test mode screen. If it is necessary, adjust the monitor by referring to Section 12. Use the DEMAGNETIZER SW for the color deviation caused by the monitor's magnetization (refer to Section 9).

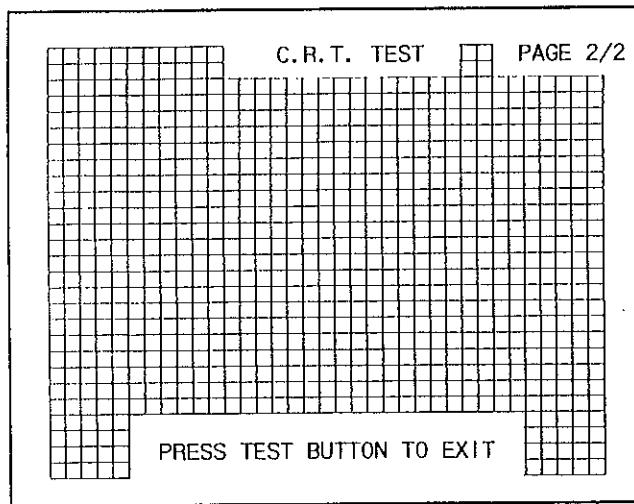

(2) INPUT TEST

INPUT TEST		
	PLAYER1	PLAYER2
START	OFF	OFF
TRIGGER	OFF	OFF
GUN-X	00	00
GUN-Y	00	00
SCREEN-IN	OUT	OUT

PRESS TEST BUTTON TO EXIT

Selecting the INPUT TEST on the test mode menu screen causes the screen (on which each switch is tested) to be displayed. Press each switch. If the display beside each switch indicates "ON," the switch and wiring connections are satisfactory.

(3) OUTPUT TEST

OUTPUT TEST		
	START1 LAMP	OFF
	START2 LAMP	OFF

→ EXIT

SELECT WITH SERVICE BUTTON
AND PRESS TEST BUTTON

The OUTPUT Test menu screen in the TEST mode allows Lamps and wiring connections to be checked. Check if each lamp lights up satisfactorily.

(4) SOUND TEST

SOUND TEST	
NO.	0

SELECT WITH SERVICE BUTTON
PRESS TEST BUTTON TO EXIT

On the Menu screen in the TEST mode, selecting SOUND TEST causes the screen (on which sound related BD and wiring connections are tested) to be displayed. Be sure to check if the sound is satisfactorily emitted from each speaker and the sound volume is appropriate.

Perform the above inspections also at the time of monthly inspection.

(2) C.R.T. TEST

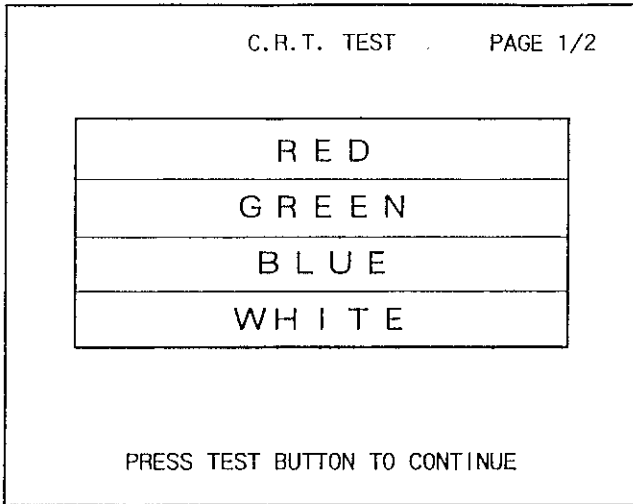

In the TEST mode menu, selecting C.R.T. TEST allows the screen (on which the monitor is tested) to be displayed. Although the monitor adjustments have been made at the time of shipment from the factory, make judgment as to whether an adjustment is needed by watching the test mode screen. If it is necessary, adjust the monitor by referring to Section 12. Use the DEMAGNETIZER SW for the color deviation caused by the monitor's magnetization (refer to Section 9).

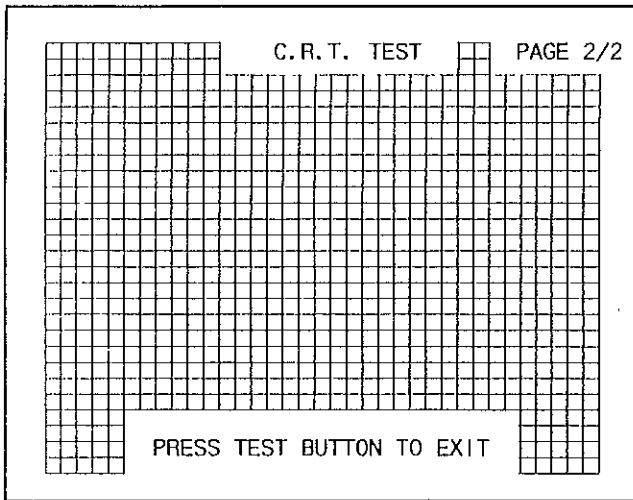

(2) INPUT TEST

INPUT TEST		
	PLAYER1	PLAYER2
START	OFF	OFF
TRIGGER	OFF	OFF
GUN-X	00	00
GUN-Y	00	00
SCREEN-IN	OUT	OUT

PRESS TEST BUTTON TO EXIT

Selecting the INPUT TEST on the test mode menu screen causes the screen (on which each switch is tested) to be displayed. Press each switch. If the display beside each switch indicates "ON," the switch and wiring connections are satisfactory.

(3) OUTPUT TEST

OUTPUT TEST		
	START1 LAMP	OFF
	START2 LAMP	OFF

→ EXIT

SELECT WITH SERVICE BUTTON
AND PRESS TEST BUTTON

The OUTPUT Test menu screen in the TEST mode allows Lamps and wiring connections to be checked. Check if each lamp lights up satisfactorily.

(4) SOUND TEST

SOUND TEST	
NO.	0

SELECT WITH SERVICE BUTTON
PRESS TEST BUTTON TO EXIT

On the Menu screen in the TEST mode, selecting SOUND TEST causes the screen (on which sound related BD and wiring connections are tested) to be displayed. Be sure to check if the sound is satisfactorily emitted from each speaker and the sound volume is appropriate.

Perform the above inspections also at the time of monthly inspection.

7. PRECAUTIONS TO BE HEEDED WHEN MOVING THE MACHINE



- When moving the machine, be sure to unplug the power plug. Moving the machine with the plug as is inserted can damage the power cord, and cause fire and electric shock hazards.
- When moving the machine on the floor, retract the Adjusters and ensure that Casters make contact with the floor. During transportation, pay careful attention so that Casters do not tread power cords and earth wires. Damaging the power cords can cause electric shock and short circuit hazards.



- When moving the product, do not push the Front Glass. The Glass part could be damaged and glass fractions can cause injury.
- When lifting the cabinet, be sure to hold the grip portions or bottom part. Lifting the cabinet by holding other portions can damage parts and installation portions due to the empty weight of the cabinet, and cause personal injury.

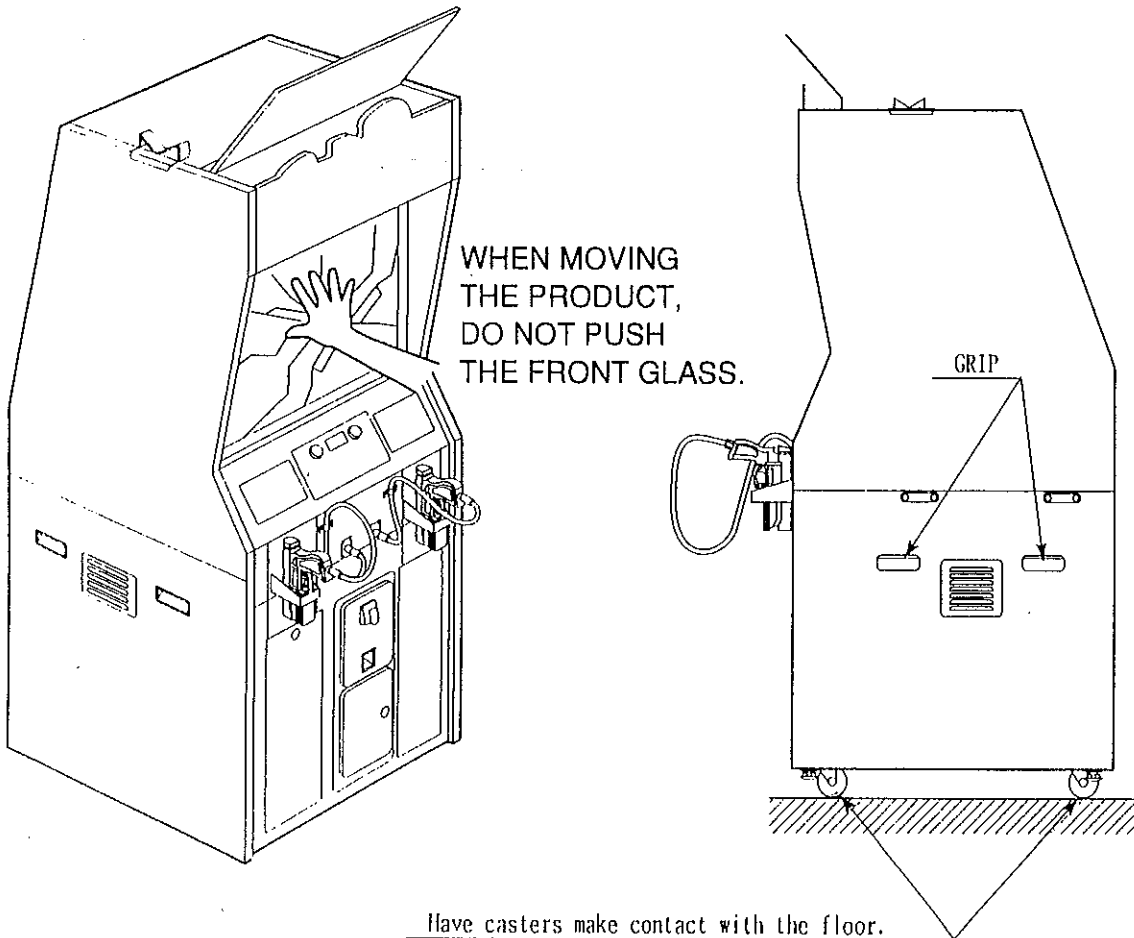
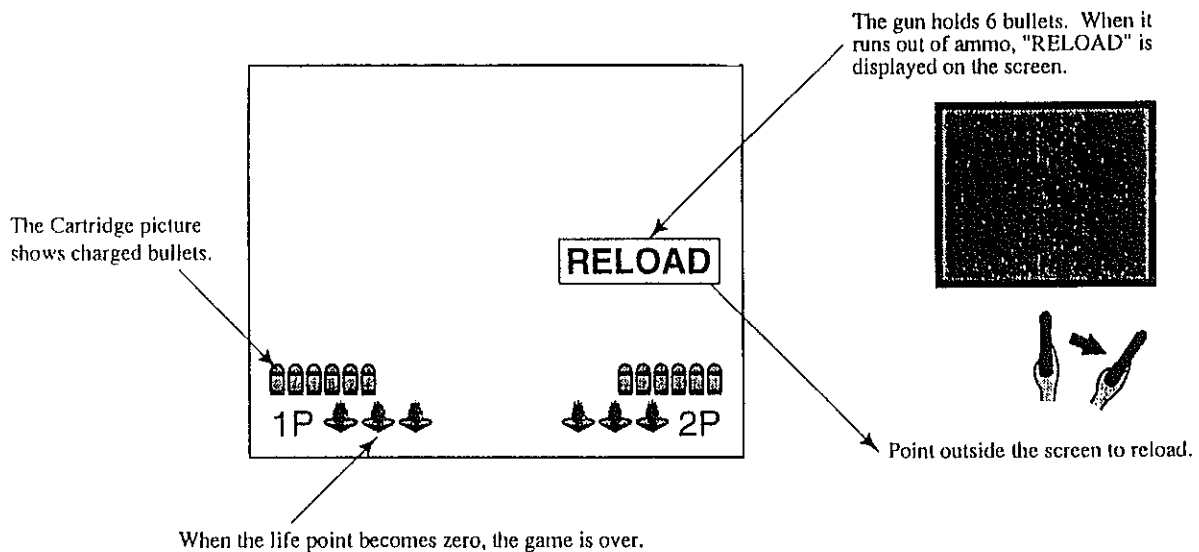

FIG. 7

8. CONTENTS OF GAME

The following explanations apply to the case the product is functioning satisfactorily. Should there be any moves different from the following contents, some sort of faults may have occurred. Immediately look into the cause of the fault and eliminate the cause thereof to ensure satisfactory operation.

- ① Inserting a coin(s) causes the credit display on the bottom of the screen to count. Inserting one credit worth coin(s) changes the message on the bottom of the screen from "INSERT COIN(S)" to "PRESS START BUTTON" and both of the start buttons will flash.
- ② Pressing either of the start buttons determines which side (left or right) you are playing on. Press the START button to start the game.
- ③ GAME DEMO follows game start. Next, Stage Title is displayed.



- The life points and the number of bullets of the left-hand side player (1P) are displayed on the lower left-hand side of the screen, and those of the right-hand side player (2P), on the lower right-hand side of the screen.
- Shooting townspeople by mistake loses one life.
- The gun holds 6 bullets. When it runs out of ammo, "RELOAD" is displayed on the screen. Point outside the screen to reload.
- The enemy's axes, knives, drum cans, barrels, etc. can be shot down for your defense.
- Shooting the background scenery can cause Special Items to appear sometimes. The Special Items can be captured by shooting. Capturing an item allows you to earn points or recovers life points (explanations as regards the Items are given later).
- When the life point becomes zero, the game is over.

⑦ BOOKKEEPING

BOOKKEEPING		PAGE1/2
GAME REPORT		
NUMBER OF GAMES		-
1P GAMES		-
2P GAMES		-
NUMBER OF CONTINUE		-
1P GAMES		-
2P GAMES		-
TOTAL TIME	-D-H-M-S	
PLAY TIME	-D-H-M-S	
AVERAGE PLAY TIME	--M-S	
LONGEST PLAY TIME	--M-S	
SHORTEST PLAY TIME	--M-S	
PRESS TEST BUTTON TO CONTINUE		

FIG. 9.3 k BOOKKEEPING (1/2)

- **NUMBER OF GAMES (CONTINUE):**
The total number of games played (continued) on 1P side and 2P side.
- ***P GAMES:**
Displays the number of games played (continued) on 1P side and 2P side respectively.
- **TOTAL TIME:**
Refers to TOTAL TIME energized except for the time used for the TEST Mode.
- **PLAY TIME:**
Refers to the game play time.

By-playtime play frequency bookkeeping is displayed in increments of 30 seconds from 0M00S to 9M59S. Playtime in excess of 10 minutes is displayed all in the category of OVER 10 M00S.

BOOKKEEPING		PAGE2/2
THE HISTOGRAM		
0M00S ~ 0M29S		-
0M30S ~ 0M59S		-
1M00S ~ 1M29S		-
1M30S ~ 1M59S		-
2M00S ~ 2M29S		-
2M30S ~ 2M59S		-
3M00S ~ 3M29S		-
3M30S ~ 3M59S		-
4M00S ~ 4M29S		-
4M30S ~ 4M59S		-
5M00S ~ 5M29S		-
5M30S ~ 5M59S		-
6M00S ~ 6M29S		-
6M30S ~ 6M59S		-
7M00S ~ 7M29S		-
7M30S ~ 7M59S		-
8M00S ~ 8M29S		-
8M30S ~ 8M59S		-
9M00S ~ 9M29S		-
9M30S ~ 9M59S		-
OVER 10M00S		-
PRESS TEST BUTTON TO EXIT		

FIG. 9.3 k BOOKKEEPING (2/2)

10. CONTROLLER



- In order to prevent an electric shock and short circuit, be sure to turn power off before performing work by touching the interior parts of the product.
- Be careful so as not to damage wirings. Damaged wiring can cause an electric shock or short circuit accident.

In the cases where the controller's operation is not satisfactory or the controller sight deviates from the direction in which the controller is pointed, the controller's interior parts may have been damaged. Replace the parts by disassembling the controller in the following procedure: Also, be sure to perform sighting check in the test mode when the controller parts are replaced.

REPLACING THE MICROSWITCH

- ① Disassemble the controller.
- ② Pull out the microswitch from COVER RIGHT.
- ③ Take out the microswitch by removing the soldering from it.
- ④ Bend the new Microswitch Actuator as shown.
- ⑤ Solder the new microswitch and assemble the controller.
- ⑥ By operating the Trigger, check if the Microswitch can be turned ON/OFF correctly.

REPLACING THE SENSOR UNIT

- ① Disassemble the controller.
- ② Remove the sensor unit from COVER.

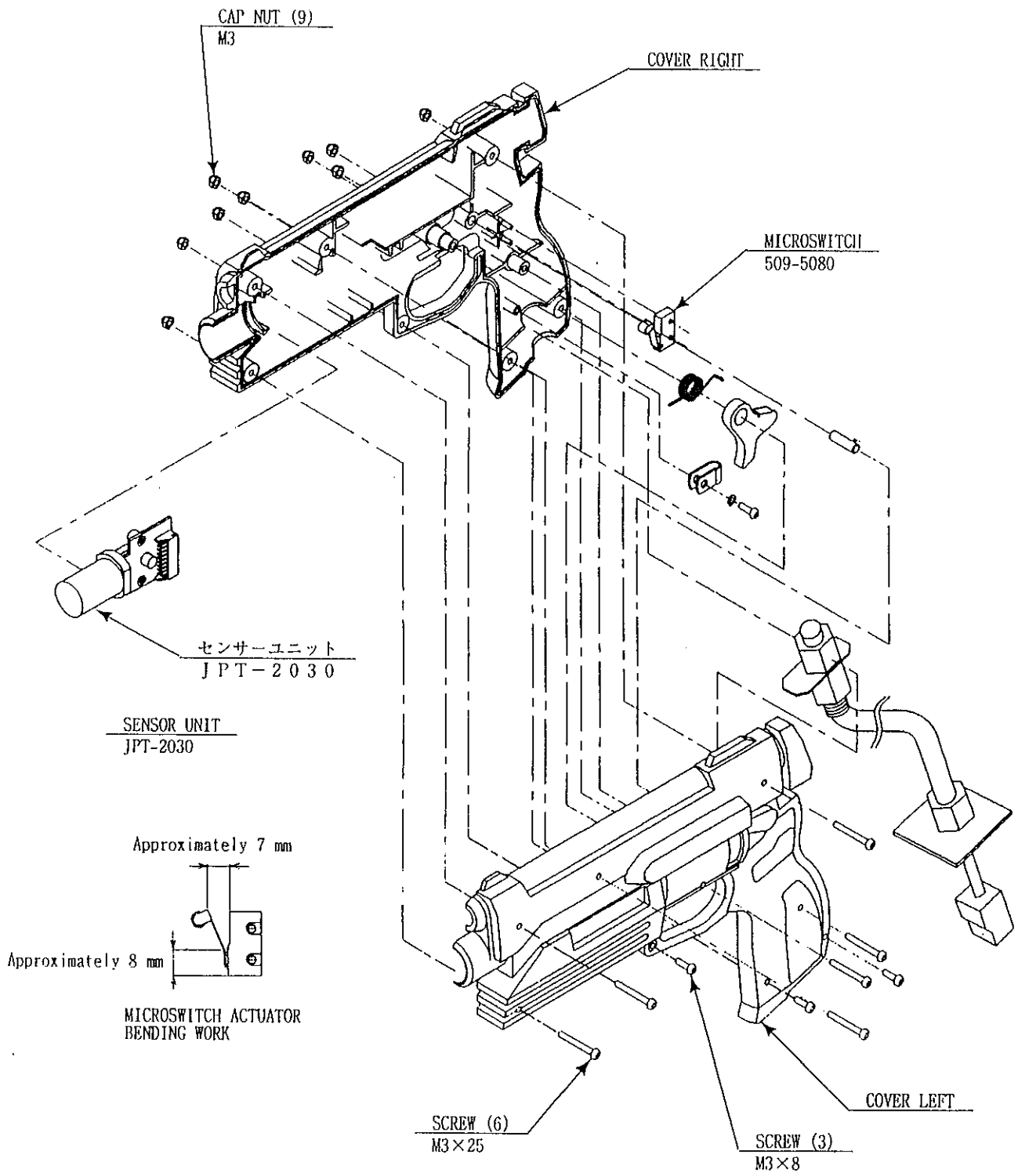

FIG. 10

11. COIN SELECTOR

HANDLING THE COIN JAM

If the coin is not rejected when the REJECT button is pressed, open the coin chute door and open the selector gate. After removing the jammed coin, put a normal coin in and check to see that the selector correctly functions.

CLEANING THE COIN SELECTOR



- Remove and clean smears by using a soft cloth dipped in water or diluted chemical detergent and then squeezed dry.
- Never apply machine oil, etc. to the Coin Selector.
- After cleaning the Coin Selector, insert a regular coin in the normal working status and ensure that the Selector correctly functions.

The coin selector should be cleaned once every 3 months. When cleaning, follow the procedure below:

- ① Turn the power for the machine OFF. Open the coin chute door.
- ② Open the gate and dust off by using a soft brush (made of wool, etc.).
- ③ Remove and clean smears by using a soft cloth dipped in water or diluted chemical detergent and then squeezed dry.
- ④ Remove the CRADLE.
When removing the retaining ring (E ring), be very careful so as not to bend the rotary shaft.
- ⑤ Remove stain from the rotary shaft and pillow portions by wiping off with a soft cloth, etc.
- ⑥ After wiping off as per ⑤ above, further apply a dry cloth, etc. to cause the coin selector to dry completely.

COIN INSERTION TEST

Once every month, when performing the Coin SW Test, simultaneously check the following:

- Does the Coin Meter count satisfactorily?
- Does the coin drop into the Cashbox correctly?
- Is the coin rejected when inserted while keeping the Reject Button pressed down?

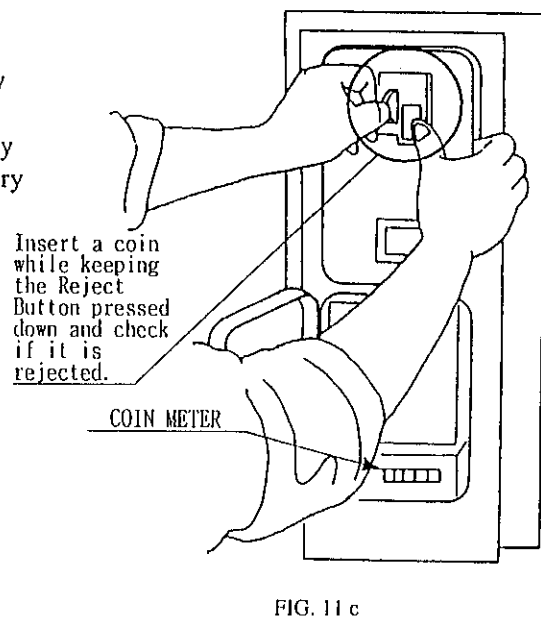
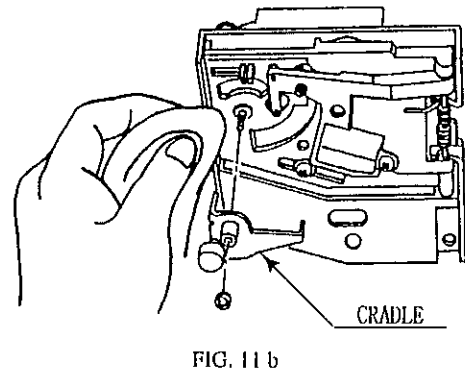
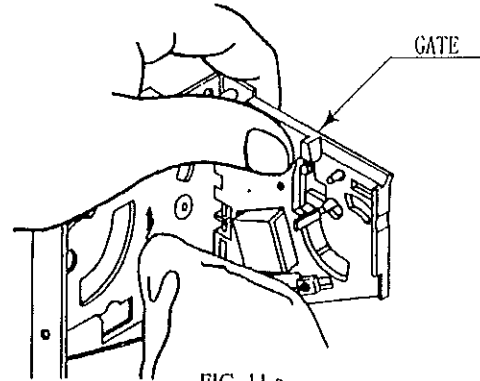

12. MONITOR

12-1 CAUTIONS AND WARNINGS CONCERNING THE SAFETY FOR HANDLING THE MONITORS

Before handling the monitors, be sure to read the following explanations and comply with the caution/warning instructions given below. Note that the caution/warning symbol marks and letters are used in the instructions.



Indicates that handling the monitors erroneously by disregarding this warning may cause a potentially hazardous situation, which could result in death or serious injury.



Indicates that handling the monitors by disregarding this caution may cause a potentially hazardous situation, which could result in personal injury and or material damage.



Indicates that access to a specific part of the equipment is forbidden.



Indicates the instruction to disconnect a power connector or to unplug.



- When performing such work as installing and removing the monitor, inserting and disconnecting the external connectors to and from monitor interior and the monitor, be sure to disconnect the power connector (plug) before starting the work. Proceeding the work without following this instruction can cause electric shock or malfunctioning.
- Using the monitor by converting it without obtaining a prior permission is not allowed. SEGA shall not be liable for any malfunctioning and accident caused by said conversion.



- **Primary side and Secondary side**
The monitor's circuit which is divided into the Primary side and Secondary side, is electrically isolated. Do not touch the primary side, or do not touch both the primary side and the secondary side simultaneously. Failing to observe the instruction can cause electric shock and this is very dangerous. When making monitor adjustments, use a non-conductive driver and make adjustment without touching any part other than the Adjustment V. R. and knob. Also, be sure not to cause a short-circuit to the Primary side and Secondary side. If short-circuited, it can cause electric shock or malfunctioning, which is very dangerous.

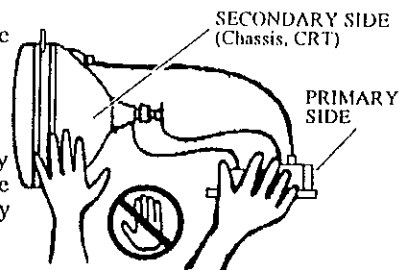

- **High-tension Voltage**

Some of the parts inside monitor are subject to high-tension voltage in excess of 20,000 volts and very dangerous. Therefore, do not touch the monitor interior. Should soldering & paper wastes, etc. be mixed in the monitor interior, turn the power off so as not to cause malfunctioning or fire hazard.

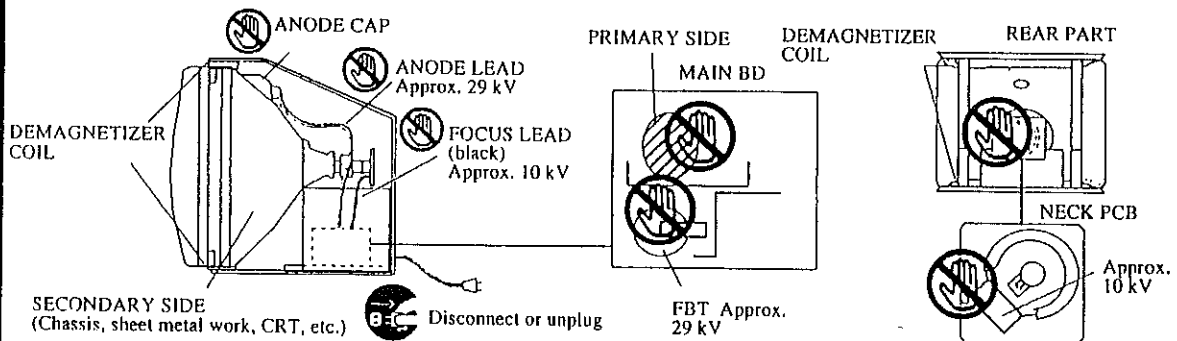

- **Connecting the CRT and PCB**

For combining the CRT and PCB, use the specified part No. to maintain the status of adjustments made at the factory. The anode of the CRT itself will be accumulatively charged as time elapses, generating high-tension voltage which is very dangerous. The monitor should be used with the Chassis, CRT and PCB assembled. When repair, etc. is required at the time of malfunctioning, be sure to send it in an "as is assembled" condition. If these are disassembled, what's charged to said high tension voltage can be discharged, causing a very hazardous situation. Therefore, under no circumstances should it be disassembled.



- **Static Electricity**
Touching the CRT surface sometimes causes you to slightly feel electricity. This is because the CRT surfaces are subject to static and will not adversely affect the human body.
- **Installation and removal**
Ensure that the Magnetizer Coil, FBT (Fly-Back Transformer), Anode Lead and Focus Lead are not positioned close to the sheet metal work's sharp edges, etc. and avoid damaging the insulated portions so as not to cause electric shock and malfunctioning. (For the name of parts, refer to the above Figures).



For the purpose of static prevention, special coating is applied to the CRT face of this product. To protect the coating, pay attention to the following points. Damaging the coating film can cause electric shock to the customers.

- Do not apply or rub with a hard item (a rod with pointed edge, pen, etc.) to or on the CRT surfaces.
- Avoid applying stickers, seals, etc. on the CRT face.
- Do not remove aluminum foils from the CRT corners. Removing the aluminum foils can cause static prevention effects to be lowered.

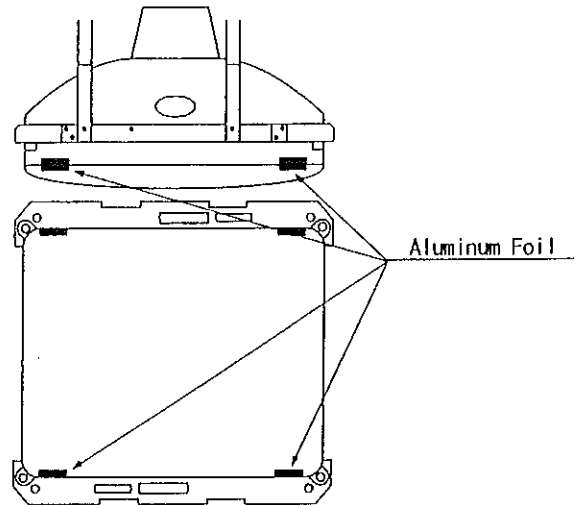

12-2 CLEANING THE CRT



Use care when handling the glass made parts. If glass made parts are damaged, the glass fractions can cause injury.



- When cleaning the CRT, be sure to use a soft, dry cloth. Do not use chemicals such as thinner, benzene, etc.
- Apply anti-static agent, which prevents dust attachment, only to the CRT face.

Be sure to turn power off before cleaning the CRT.

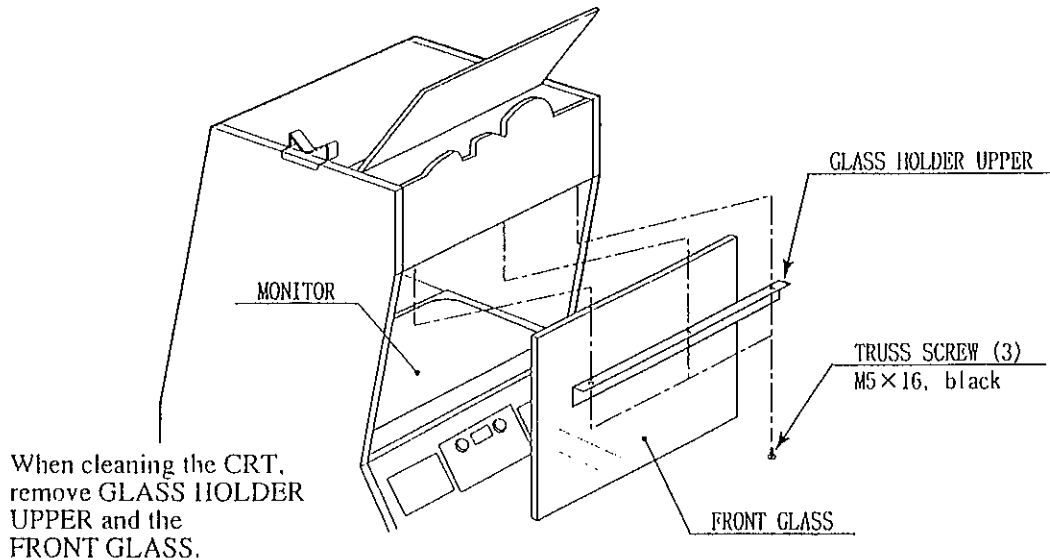

FIG. 12.2

12-3 ADJUSTMENT METHOD



- Monitor adjustments have been made at the time of shipment. Therefore, do not make further adjustment without a justifiable reason. Adjusting the monitor which contains high tension parts is a dangerous work. Also, an erroneous adjustment can cause deviated synchronization and image fault, resulting in malfunctioning.
- When making adjustment, utilize a resinous Alignment Rod. Servicing with bare hand or using conductive tools can cause electric shock.

Remove the back door at the rear of the cabinet, and the monitor adjustment knob appears.

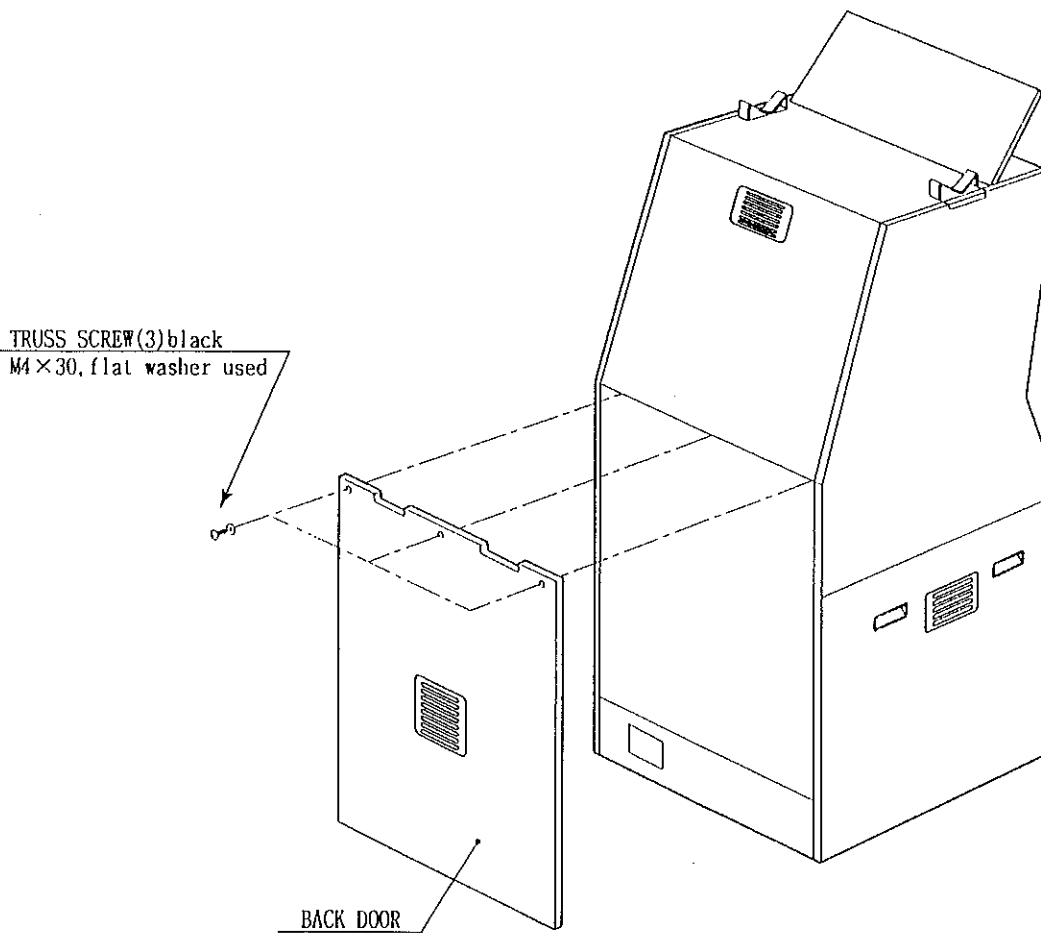
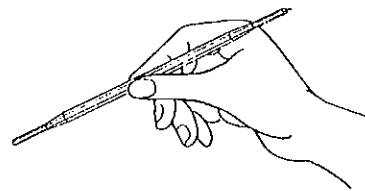

FIG. 12.3 a



For adjustment, use the Resinous Adjustment Rod.

FIG. 12.3 b

NANAO monitor: 2 0 0 - 5 7 8 7 - 0 1 (31K mode)

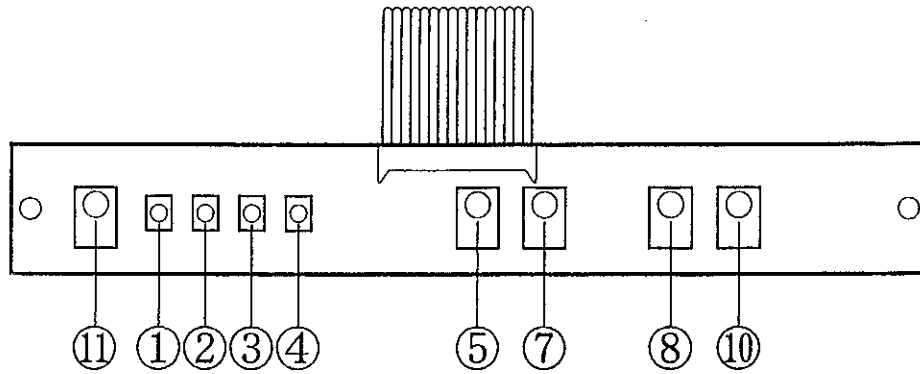

- ① R-GAIN.....
- ② G-GAIN Controls colors.
- ③ B-GAIN.....
- ④ BRIGHT Controls screen brightness.
- ⑤ H. SIZE Controls horizontal screen size.
- ⑦ H. POSI Controls horizontal display position on screen.
- ⑧ V. SIZE Controls vertical screen size.
- ⑩ V. POSI Controls vertical display position on screen.
- ⑪ CONTRAST.... Adjusts image contrast.

13. REPLACING THE FLUORESCENT LAMP, AND LAMPS



- When performing work, be sure to turn power off. Working with power on can cause electric shock and short circuit hazards.
- The Fluorescent Lamp, when it gets hot, can cause burn. Be very careful when replacing the Fluorescent Lamp.
- Be sure to use lamps of the designated rating. Using lamps of undesignated rating can cause a fire or malfunctioning.



To perform work safely and securely, be sure to prepare a step which is in a secure and stable condition. Not using a step or using an unstable step can cause violent falling down accidents.

13 - 1 REPLACING THE FLUORESCENT LAMP

After removing Lamp Cover B and Billboard Plate by referring to [I](#), Section 6, take out the 2 screws, remove Lamp Cover A, and replace the Fluorescent Lamp.

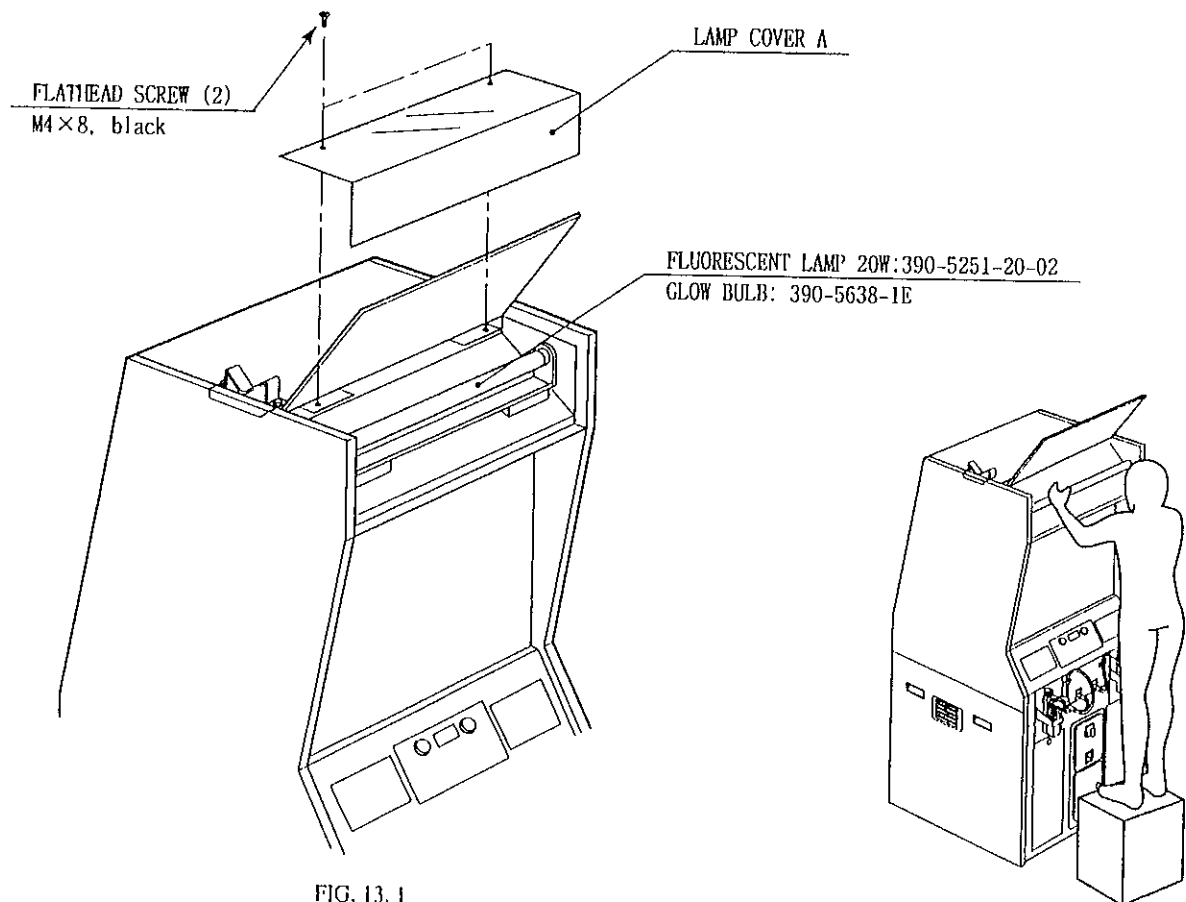

When performing work,
prepare a step.

13 - 2 REPLACING THE LAMP

- ① Take out the 4 truss screws and remove the Switch Panel. At this time, be careful so as not to damage wiring.

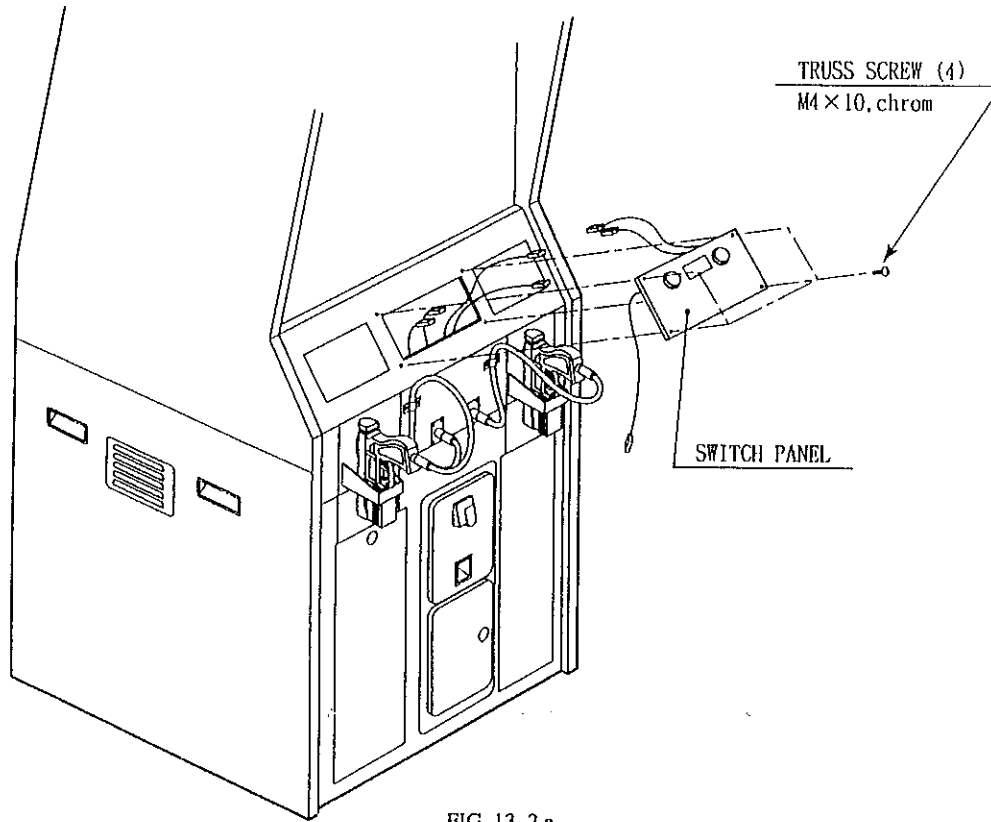

FIG. 13. 2 a

- ② Pull the lower part of the Switch from the rear of the Switch Panel and remove the Switch part to replace the lamp.

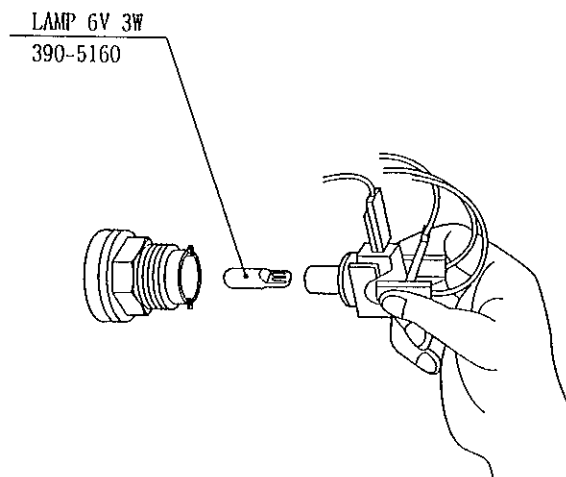

FIG. 13. 2 b

14. PERIODIC INSPECTION TABLE

The items listed below require periodic check and maintenance to retain the performance of this machine and to ensure safe business operation.



- Be sure to check once a year to see if Power Cords are damaged, the plug is securely inserted, dust is accumulated between the Socket Outlet and the Power Plug, etc. Using the product with dust as is accumulated can cause fire and electric shock hazards.
- Periodically once a year, request the place of contact herein stated or the Distributor, etc. where the product was purchased from, as regards the internal cleaning. Using the product with dust as is accumulated in the interior without cleaning can cause a fire or accident. Note that cleaning the interior parts can be performed on a pay-basis.

TABLE 14

	Item	Interval	Reference
CABINET	Check Adjusters' contact with surface.	Daily	3
CONTROLLER	Cleaning	As necessary	
	Sight check	Weekly	9, 10
	Check SWes.	Monthly	9, 10
COIN CHUTE DOOR	Check COIN SW.	Monthly	9
	Coin insertion test.	Monthly	11
	Cleaning of COIN SELECTOR.	Trimonthly	11
MONITOR	Cleaning CRT face.	Weekly	12
	Check adjustments.	Monthly	6, 9, 12
FRONT GLASS, MIRROR	Cleaning	Weekly	See next page.
GAME BD	Check settings.	Monthly	9
	MEMORY TEST.	Monthly	9
INTERIOR	Cleaning	Annually	See above.
POWER SUPPLY PLUG	Inspection and cleaning		
Cabinet surfaces	Cleaning	As necessary.	See below.

CLEANING THE CABINET SURFACES

When the cabinet surfaces are badly soiled, remove stains with a soft cloth dipped in water or diluted (with water) chemical detergent and squeezed dry. To avoid damaging surface finish, do not use such solvents as thinner, benzine, etc. or abrasives, bleaching agent and chemical dustcloth.

CLEANING THE FRONT GLASS AND MIRROR

When cleaning, be sure to comply with the following CAUTION and instructions so as to ensure that the front glass and mirror are not damaged.



Use care when handling glass made parts. When the glass is damaged, fragments of glass can cause injury.



- Be sure to use the accessory glass cleaner or high-efficiency alkaline cleansing water. To avoid damaging the glass surfaces, do not use solutions such as thinner and alcohol, or abrasives, nor bleaching agents.
- Use a soft cloth.
- When removing an attached large particle of dust (or foreign matter), do not rub with a cloth.

Remove the front glass when cleaning the front glass and mirror. First, remove GLASS HOLDER UPPER only. Then, put your hand through the square hole in the back side of GLASS HOLDER UPPER, and pull the front glass toward you.

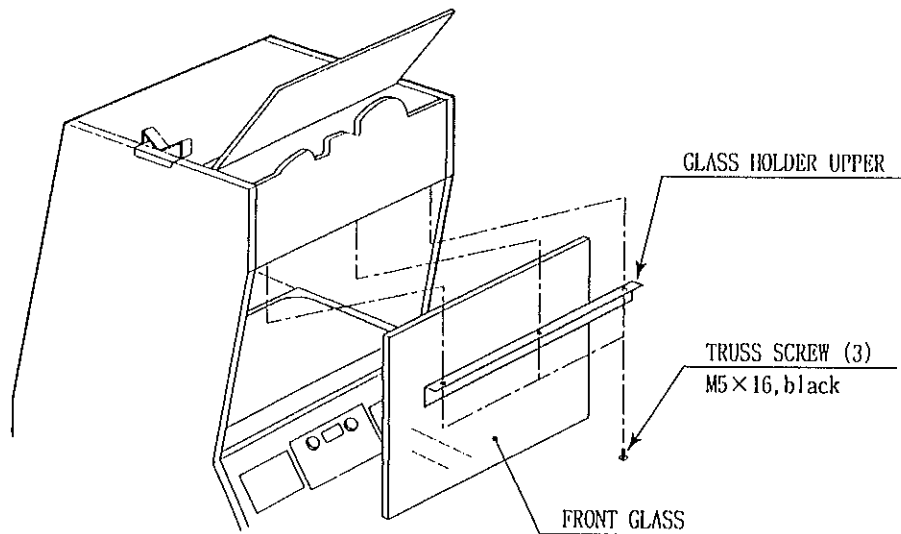

FIG. 14

15. TROUBLESHOOTING

In case a problem occurs, first check wiring connector connections.



- In order to prevent electric shock and short circuit hazards, be sure to turn power off before performing work.
- Be careful so as not to damage wirings. Damaged wiring can cause electric shock and short circuit hazards.
- After removing the cause of the functioning of the Circuit Protector, reinstate the Circuit Protector. Depending on the cause of the functioning, using the Circuit Protector as is without removing the cause can cause generation of heat and fire hazard.

TABLE 15 a

PROBLEMS	CAUSE	COUNTERMEASURES
When the main SW is turned ON, the machine is not activated.	<p>The power is not ON.</p> <p>Incorrect power source/voltage.</p> <p>AC UNIT CIRCUIT PROTECTOR functioned due to instantaneous overcurrent.</p> <p>The CONNECT BOARD fuse is blown due to the momentary overload.</p>	<p>Firmly insert the plug into the outlet.</p> <p>Make sure that the power supply/voltage are correct.</p> <p>First, remove the cause of overcurrent and reinstate the circuit protector to its original status (see [3], Section 6, Refer to the following).</p> <p>After eliminating the cause of overload, replace the CONNECT BOARD fuse (see photo 15). 514-5036-5000 FUSE 6.4 ϕ \times 30 5000mA 125V</p>
The color on MONITOR screen is incorrect.	Image adjustment is inappropriate.	Adjust appropriately (see Sec.12).
The on-screen image of the monitor sways and or shrinks.	The power source and voltage are not correct.	Make sure that the power supply and voltage are correct.

CIRCUIT PROTECTOR

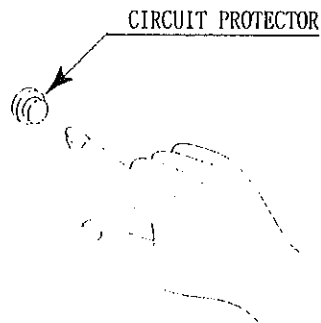

Functions due to the activation of bimetal. To restore the function, wait for approximately one minute or longer until the bimetal cools off. (Press the Button.)

FIG. 15 a

TABLE 15 b

PROBLEMS	CAUSE	COUNTERMEASURES
No sound is emitted.	Sound volume adjustment is not appropriate. Board and Amplifier malfunctioning.	Adjust sound volume (see Sec. 9). Perform the sound test and confirm (see Sec. 9).
Controller sighting is not satisfactory.	Due to environmental changes, etc., sighting became inappropriate. LED BD malfunctioning. Sensor Unit malfunctioning. LED BD, Front Glass, and Mirror are soiled.	Perform sighting adjustment in the test mode (see Sec. 9). Check to ensure that the LED lights up. If it does not light up, replace (see next page). Replace the Sensor Unit (see Sec.10). Wipe off soiled surfaces (see Sec. 14 and next page).
During game play, the Controller is not operable for shooting.	Malfunctioning of microswitch. Malfunctioning of LED BD. Malfunctioning of Sensor Unit.	Check for ON and OFF in the INPUT test and if it is not functioning, replace the microswitch (see Sec.10). Check if the LED is lit, and if is not lit, replace (see next page). Replace the Sensor Unit.
The Fluorescent lamp does not light up.	The Fluorescent tube is burnt out.	Replace the Fluorescent tube (see Sct. 13).
The Lamp does not light up.	Lamp malfunctioning.	Replace the Lamp (see Sec. 13).

REPLACEMENT OF LED BD

If the light emission of 2 LED's can not be seen, the fault or malfunctioning may be considered. Replace by using the following procedure. Also, when wiping off the soils, remove the ASSY SENSOR as per the same procedure.

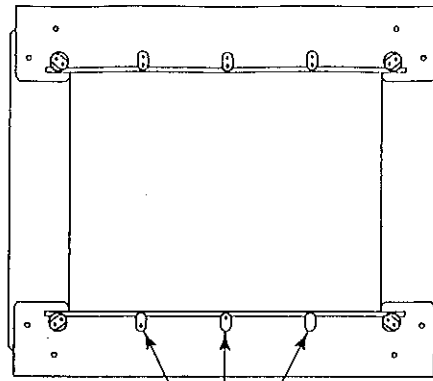

If light emission from the 2 LED's can not be seen, replace.

FIG. 15 a

- ① Turn power off.
- ② Remove the Back Door.
- ③ Disconnect the ASSY SENSOR CONNECTOR.
- ④ Pull out the ASSY SENSOR.

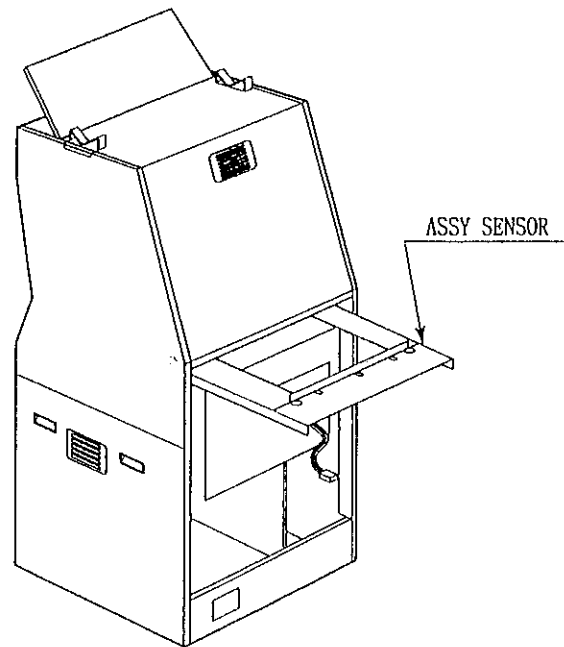

FIG. 15 b

- ⑤ Disconnect the connector from the both ends of the LED BD which shows defects.
- ⑥ Take out the 2 U Nuts to remove and replace the LED BD.

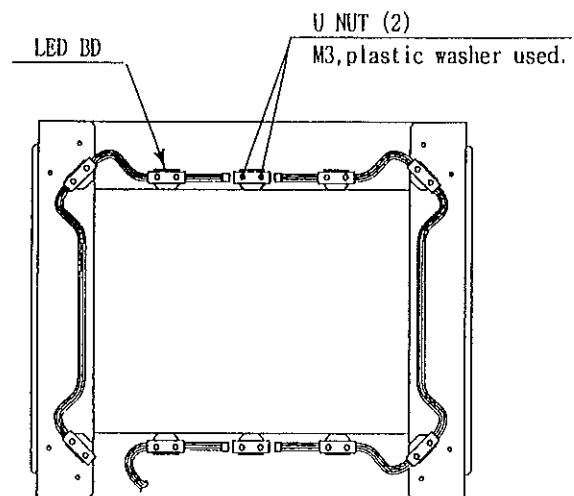

FIG. 15 c

REPLACEMENT OF FUSE



- In case fuse replacements other than those stated in this manual are necessary, contact where you purchased the product from for inquiries regarding this matter.
- Fuse replacements other than those specified can cause hazards and are strictly forbidden.
- In order to prevent an electric shock, be sure to turn power off and unplug from the socket outlet before performing work by touching the internal parts of the product.
- Be careful so as not to damage wirings. Damaged wiring can cause electric shock and short circuit hazards.
- Be sure to use fuses meeting specified rating. Using fuses exceeding the specified rating can cause fire and electric shock hazards.
- After eliminating the cause of the blowing of fuse, replace the fuse. Depending on the cause of fuse blowing, continued use with the fuse as is blown can cause generation of heat and fire hazard.

Remove the Back Door by referring to 12-3, and the fuse appears at the position shown in Photo 15.

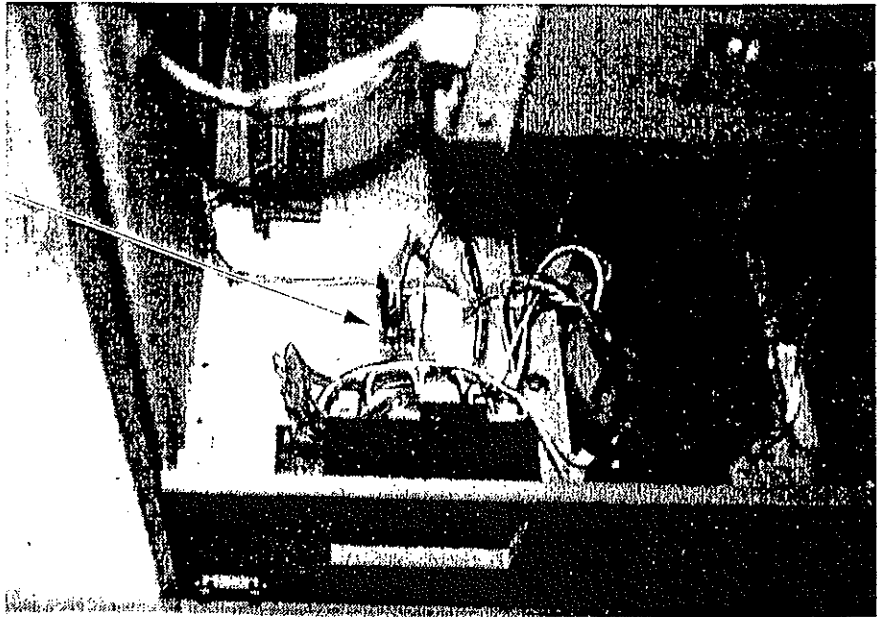

PHOTO 15

16. GAME BOARD



- In order to prevent electric shock and short circuit hazards, be sure to turn power off before performing work.
- Be careful so as not to damage wirings. Damaged wiring can cause fire, electric shock and short circuit hazards.
- Do not expose the Game BD, etc. without a good reason. Failure to observe this can cause electric shock hazard or malfunctioning.



In this product, setting changes are made during the test mode. The Game BD need not be operated. Use the Game BD, etc. as is with the same setting made at the time of shipment so as not to cause electric shock and malfunctioning.

16 - 1 REMOVING THE BOARD

To replace the IC BD (such as GAME BD, I/O BD, etc.) , take out the IC BD by using the following procedure:

- ① Turn the MAIN SW off.
- ② Take off the screw to unlock and open FRONT DOOR LEFT. Depending on cabinets, the front door may not have this screw.
- ③ The shield case is contained inside FRONT DOOR LEFT.
- ④ Disconnect all the Connectors which connect the Base and the Cabinet.
- ⑤ The shield case is secured to the base (wooden). Take off the wing bolt which secures the base to the cabinet and take out the shield case together with the base.
- ⑥ Take off the 2 screws to remove the case lid. The game BD is contained in the shield case.

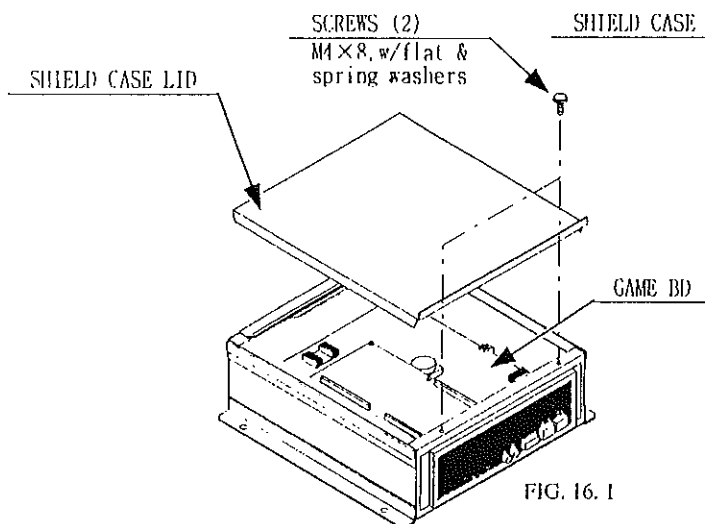

FIG. 16.1

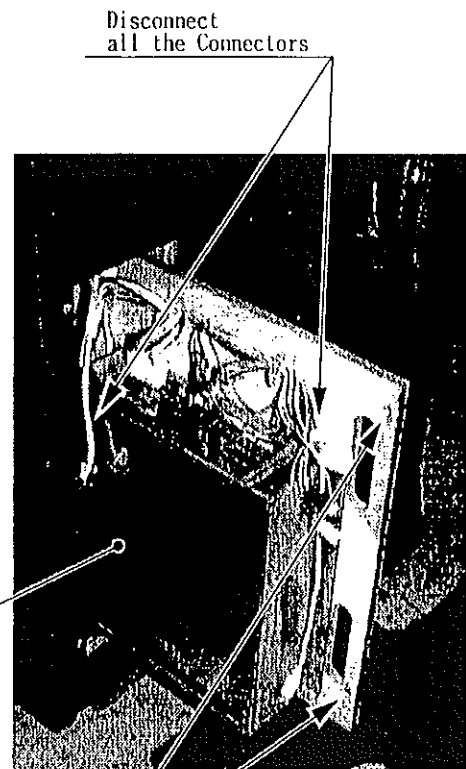

PHOTO 16.1

16 - 2 COMPOSITION OF GAME BOARD

GAME BD HOD USA (833-13635-01):For USA
GAME BD HOD EXP (833-13635-02):For OTHERS
GAME BD HOD KOR (833-13635-03):For KOREA
GAME BD HOD AUS (833-13635-04):For AUSTRALIA

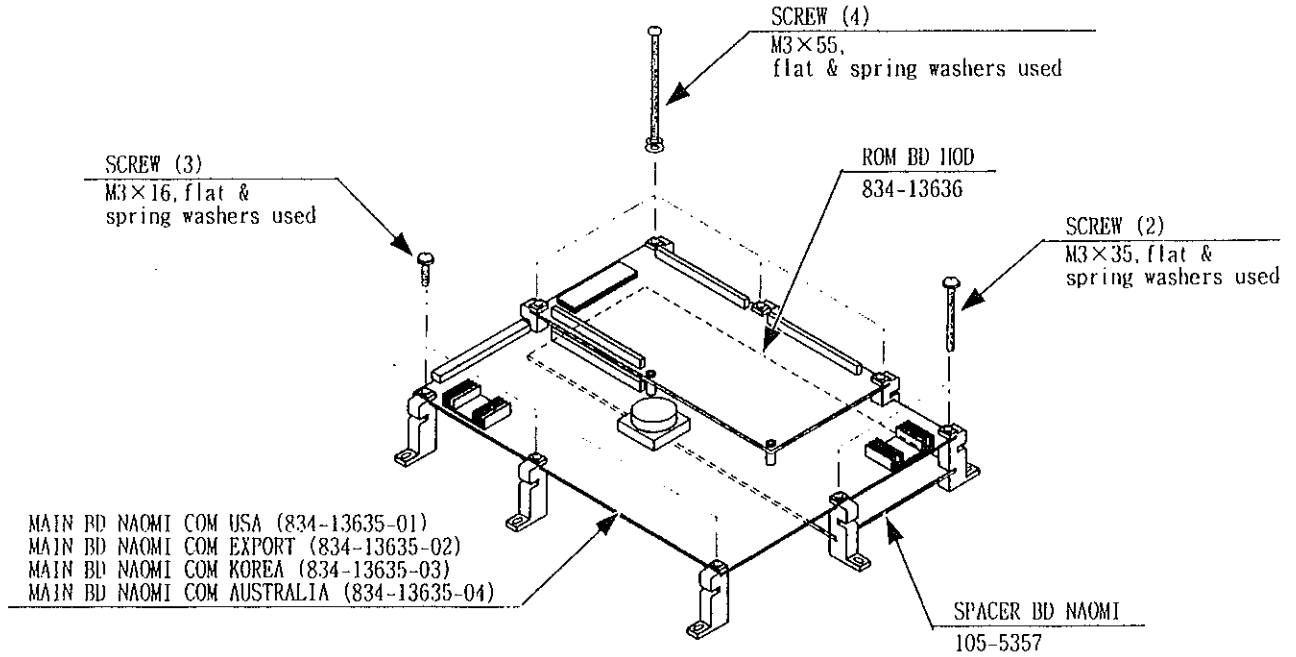
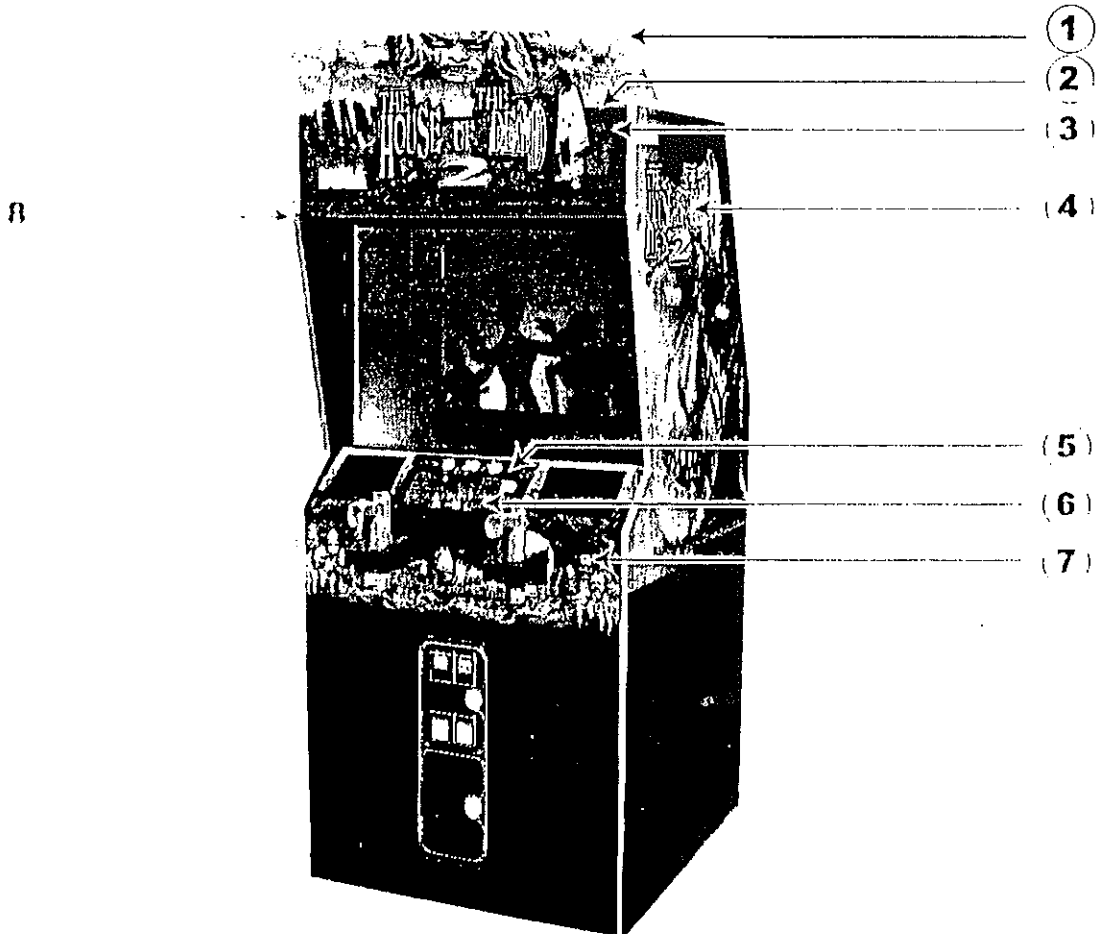

FIG. 16.2

17. DESIGN RELATED PARTS

For the Warning Display stickers, refer to Section 1.



- | | | | |
|----------|--|----------|---|
| 1 | 423-0326
BILLBOARD PLATE R HOD U/ R | 5 | HOD-2301
INSTR PLATE HOD U/ R |
| 2 | HOD-3504
LANP COVER-B | 6 | 422-0713-01
PLAY INSTR SH HOD U/ R ENG |
| 3 | 423-0325
BILLBOARD PLATE HOD U/ R | 7 | HOD-2201-B
CONT PNL SEET HOD |
| 4 | HOD-1504
STICKER SIDE R HOD U/ R | 8 | HOD-1503
STICKER SIDE L HOD U/ R |

18. PARTS LIST

① TOP ASSY HOD U/R

(D-1/2)

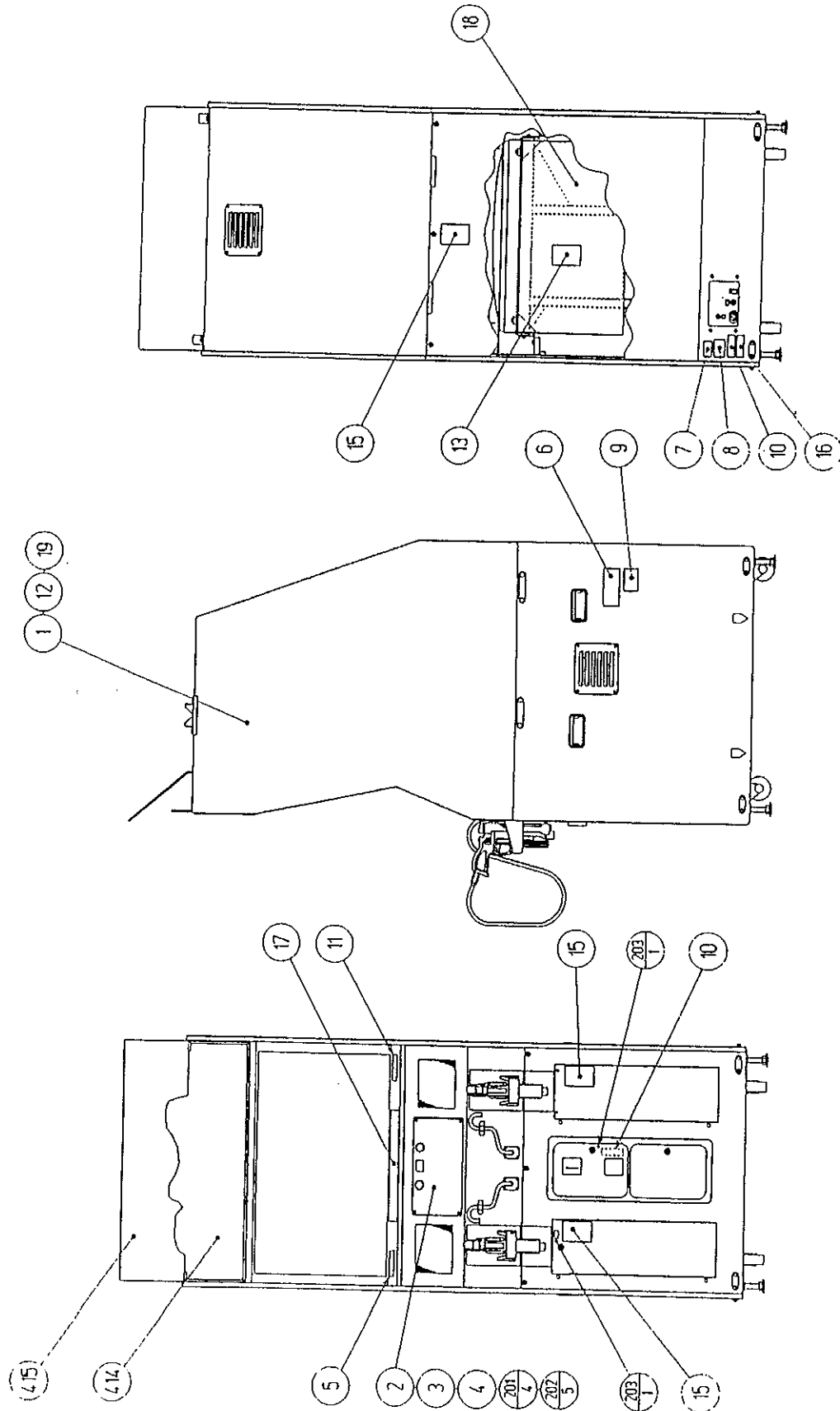

① TOP ASSY HOD U/R

(D-2/2)

ITEM NO.	PART NO.	DESCRIPTION	NOTE
1	HOD-10001	ASSY CABINET U/R	
2	HOD-2300	ASSY SW PANEL	
3	422-0713-01	PLAY INSTR SH HOD U/R ENG	
4	421-10042- ~	DENOMI SH 1GAME ~	
9	421-8408	STICKER ELEC SPEC TAIWAN	TAIWAN
13	440-DS0013XEG	STICKER D MONITOR ENG	
14	SGM-4323	POLY COVER 900 × 1300 × 1800	
15	440-WS0002XEG	STICKER W POWER OFF ENG	
17	440-CS0109-EG	STICKER C ZMB U/R ENG	
18	PRC-1045	COVER	
19	421-9486-01	INSTR SH ACCESSORY ENG	
201	000-T00410-0C	M SCR TH CRM M4 × 10	
202	090-0024	S E TAPE 19MM × 50M ROLL L=70	
203	008-T00412-0B	TMP PRF SCR TH BLK M4 × 12	
401	601-6604-30	CARTON BOX 30	
402	SGM-2675	POLYETHYLENE BAG 240 × 370	
403	420-6428-04	OWNERS MANUAL HOD U/R ENG	
405	220-5576	KEY MASTER FOR 220-5575	
406	SGM-4111	KEY BAG (SGB-1035X)	
407	514-5036-5000	FUSE 6.4 × 30 5000MA 125V	
408	509-5080	SW MICRO TYPE	
409	390-5160	LAMP WG B TYPE 6V 3W	
411	600-6724	AC CABLE CONNECT TYPE 15A	TAIWAN
	600-6618	AC CABLE CONNECT TYPE FOR EXP	OTHERS
412	600-6729	AC CABLE CONNECT TYPE 15A	
413	SGM-4441	POLY BAG 780 × 1000 × 0.05	
414	423-0325	BILLBOARD PLATE HOD U/R	
415	423-0326	BILLBOARD PLATE R HOD U/R	
416	090-0174	GLASS CLEANER NAC S-100	
417	HOD-60040	WIRE HARN FREQ. CHANGE	
418	280-5009-01	CORD CLAMP 21	
/	GPD-0002X	SHIPPING BRKT	
/	421-8740	CAUTION INSTR COP U/R	
/	008-T00416-0B	TMP PRF SCR TH BLK M4 × 16	
/	421-6690-06	STICKER 110V	AC 110V AREA
/	421-6690-03	STICKER 220V	AC 220V AREA
/	421-6690-05	STICKER 240V	AC 240V AREA

② ASSY CABINET U/R (HOD-10001)

(D-1/2)

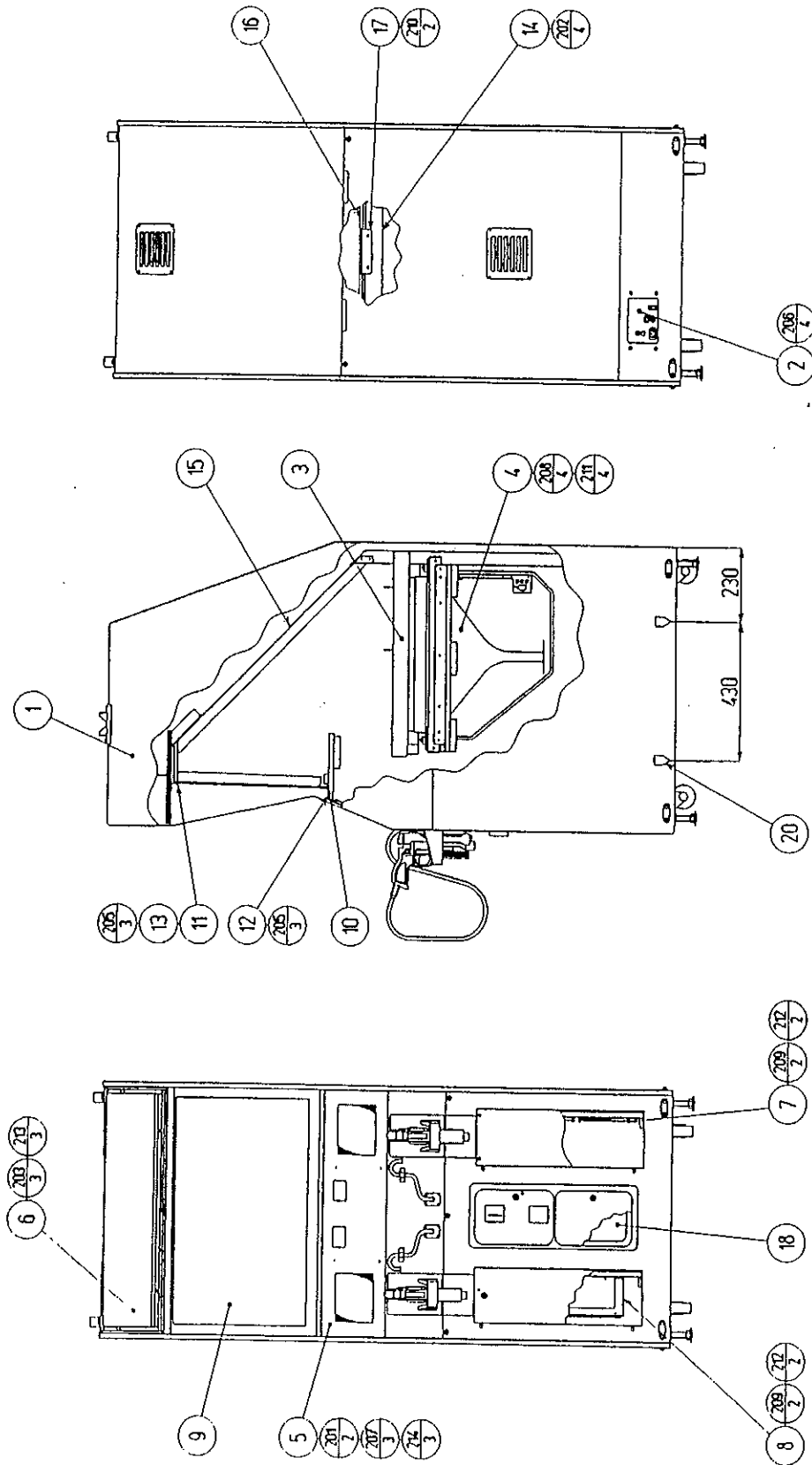

② ASSY CABINET U/R (HOD-10001)

(D-2/2)

ITEM NO.	PART NO.	DESCRIPTION	NOTE
1	HOD-1500	ASSY SUB-CABI U/R	
2	JPT-1540	AC UNIT	
3	HOD-1550	ASSY SENSOR	
4	HOD-1570	ASSY MONITOR 29 31K	
5	HOD-2200	ASSY CONT PNL U/R	
6	HOD-3500	ASSY BILLBOARD	
7	HOD-4500	ASSY PWR SPLY U/R	
8	HOD-4600	ASSY MAIN BD U/R	
9	JPT-1510	FRONT GLASS	
10	AIN-1032	RUBBER PACKING	
11	AIN-1033	GLASS HOLDER UPPER	
12	JPT-1509	GLASS HOLDER LOWER	
13	AIN-1035	CUSHION	
14	AIN-1044	MIRROR BRKT	
15	AIN-1038	MIRROR	
16	AIN-1039	MIRROR SASH	
17	AIN-1040	MIRROR HOLDER	
18	253-5366	CASH BOX	
20	421-8885	STICKER CAUTION FORK	
201	000-F00416	M SCR FH M4 × 16	
202	000-P00412-W	M SCR PH W/FS M4 × 12	
203	000-T00420-OB	M SCR TH BLK M4 × 20	
205	000-T00516-OB	M SCR TH BLK M5 × 16	
206	000-T00520-OB	M SCR TH BLK M5 × 20	
207	000-T00525-OB	M SCR TH BLK M5 × 25	
208	030-000612-S	HEX BLT W/S M6 × 12	
209	032-000430	WING BLT M4 × 30	
210	050-F00400	FLG NUT M4	
211	060-F00600	FLT WSHR M6	
212	068-441616	FLT WSHR 4.4-16 × 1.6	
213	068-441616-OB	FLT WSHR BLK 4.4-16 × 1.6	
214	069-000017-OB	FLT WSHR BLK 5.5-16 × 1.6	

③ ASSY SUB-CABI U/R (HOD-1500)

(D-1/3)

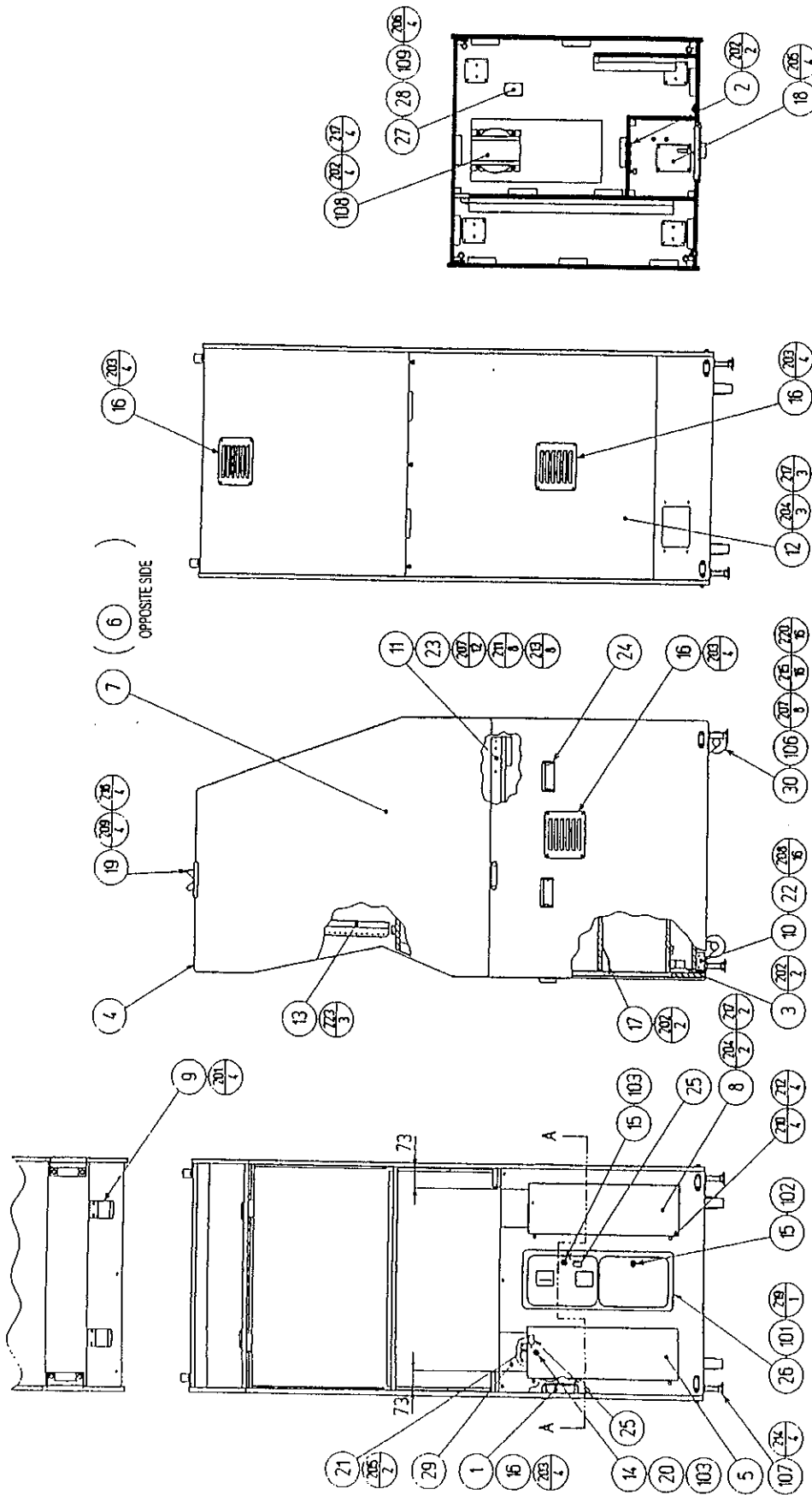

SECTION A-A

③ ASSY SUB-CABI U/R (HOD-1500)

(D-2/3)

ITEM NO.	PART NO.	DESCRIPTION	NOTE
1	HOD-1530	FAN UNIT	
2	HOD-1540	SW UNIT	
3	610-0395-01	METER UNIT S	
4	HOD-1501	WOODEN CABINET	
5	HOD-1502	FRONT DOOR L	
6	HOD-1503	STICKER SIDE L HOD U/R	
7	HOD-1504	STICKER SIDE R HOD U/R	
8	HOD-1505	FRONT DOOR R	
9	JPT-1507	HOOK BRKT	
10	ARC-1006	LEG BRACKET	
11	AIN-1008	MONITOR SUPPORT BRKT	
12	COP-1503	BACK DOOR	
13	COP-1506	WIRE COVER	
14	DP-1148X	LKG TNG	
15	DP-1167	TNG LKG	
16	253-5460-01	AIR VENT BLACK	
17	105-5169	LOCK BRACKET W	
18	105-5171	CHUTE PLATE SINGLE	
19	105-5258-01	SHIPPING HOOK BRKT RED	
20	117-0062	PLATE LOCK RETAINER	
21	117-5098	TNG RETAINER PLATE	
22	117-5233	PLATE LEG BRACKET BLACK	
23	117-5284	PLATE 6-80 BLACK	
24	253-5396	CABINET HANDLE	
26	421-7501-02	STICKER 6.3V 0.15A	
27	838-11856-01	CONNECT BD W/FUSE & COVER	
28	421-6595-05	STICKER 5A (80426)	
29	JPT-1508	PROTECT SHEET B	
30	SCR-1008	NUT PLATE FOR CASTER	
101	220-5482-91- ~	ASSY C.C 2DR ~	TAIWAN, KOREA, HONG KONG
	220-5237-92- ~	ASSY C.C 2DR ~	
102	220-5574	CAM LOCK W/KEYS	
103	220-5575	CAM LOCK MASTER W/O KEY	
104	280-5275-SR10	CORD CLAMP SR10	
105	310-5029-F20	SUMI TUBE F F 20MM	
106	601-9377	CASTER FAI=75	
107	601-5699X	LEG ADJUSTER BOLT M16 × 75	
108	560-5316	XFMR 100V5A 12.5V6A	
109	514-5036-5000	FUSE 6.4 × 30 5000MA 125V	
110	280-5009-01	CORD CLAMP 21	
111	280-0419	HARNESS LUG	
112	601-0460	PLASTIC TIE BELT 100 MM	

③ ASSY SUB-CABI U/R (HOD-1500)

(D-3/3)

ITEM NO.	PART NO.	DESCRIPTION	NOTE
201	000-P00416-W	M SCR PH W/FS M4 × 16	
202	000-P00420-W	M SCR PH W/FS M4 × 20	
203	000-T00420-OB	M SCR TH BLK M4 × 20	
204	000-T00430-OB	M SCR TH BLK M4 × 30	
205	011-T00312	TAP SCR TH 3 × 12	
206	011-T00325	TAP SCR TH 3 × 25	
207	011-T03512	TAP SCR TH 3.5 × 12	
208	030-000630-SB	HEX BLT BLK W/S M6 × 30	
209	030-000830-SB	HEX BLT W/S BLK M8 × 30	
210	031-000530-OB	CRG BLT BLK M5 × 30	
211	031-000630-OB	CRG BLT BLK M6 × 30	
212	050-F00500	FLG NUT M5	
213	050-F00600	FLG NUT M6	
214	050-H01600	HEX NUT M16	
215	060-F00600	FLT WSHR M6	
216	060-F00800-OB	FLT WSHR BLK M8	
217	068-441616-OB	FLT WSHR BLK 4.4-16 × 1.6	
218	011-F00310	TAP SCR FH 3 × 10	
219	000-P00408-W	M SCR PH W/FS M4 × 8	
220	030-000625-S	HEX BLT W/S M6 × 25	
221	050-F00400	FLG NUT M4	
222	010-P00406-F	S-TITE SCR PH W/F M4 × 6	
223	012-P00308-OB	TAP SCR #2 PH BLK 3 × 8	
301	600-6455-02	WIRE HARN C. C DOOR SINGLE	
302	600-6709-52	WIRE HARN EARTH 400MM	
303	600-6709-54	WIRE HARN EARTH 150MM	
315	600-6743-200	ASSY RGB CABLE 200CM	
317	HOD-6001	ASSY WIRE CABINET U/R	
318	600-6925-049	WIRE HARN EARN EARTH ASSY SENSOR	

④ FAN UNIT (HOD-1530)

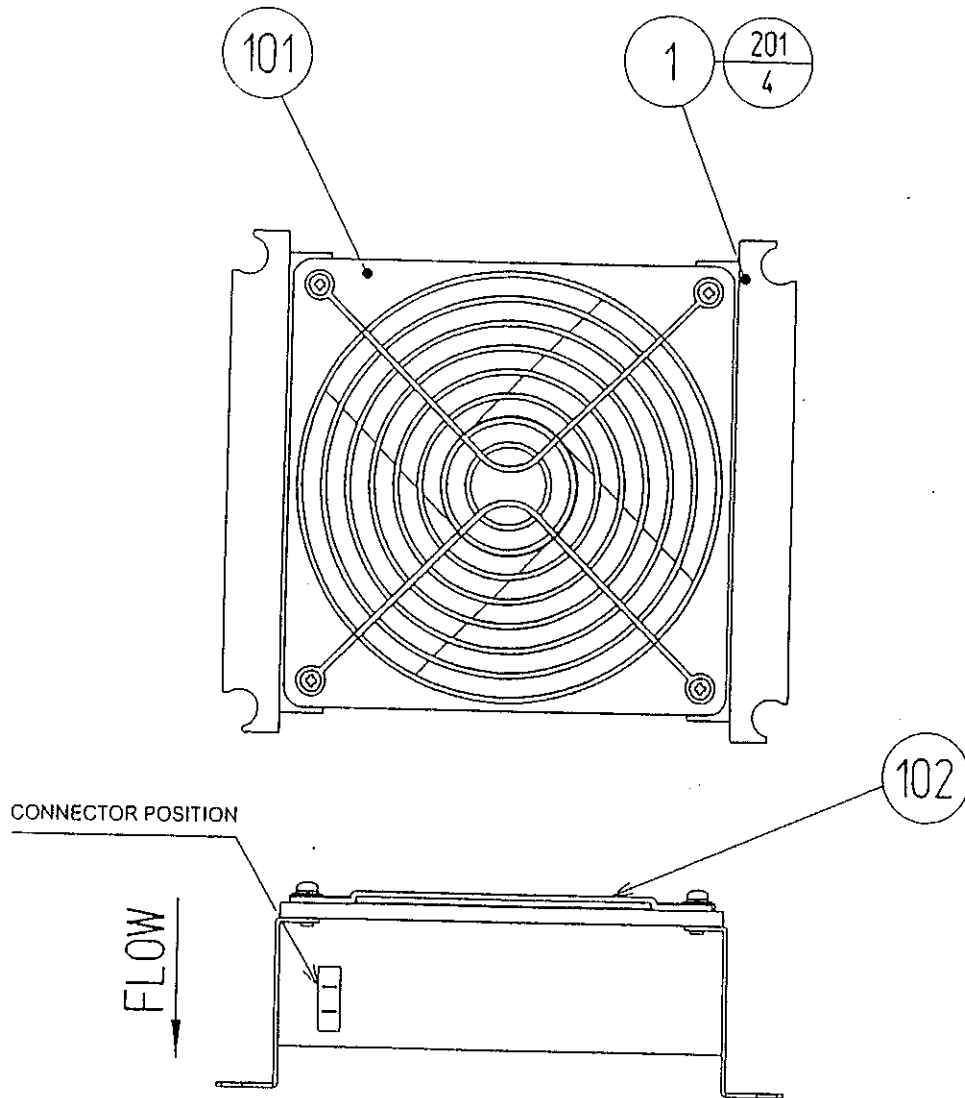

ITEM NO.	PART NO.	DESCRIPTION	NOTE
1	105-5340-01	FAN BRKT LONG	
101	260-0011-02	AXIAL FLOW FAN AC100V 50-60HZ	
102	601-8543	FAN GUARD	
103	280-5275-SR10	CORD CLAMP SR10	
201	000-P00312-W	M SCR PH W/FS M3 × 12	

⑤ SW UNIT (HOD-1540)

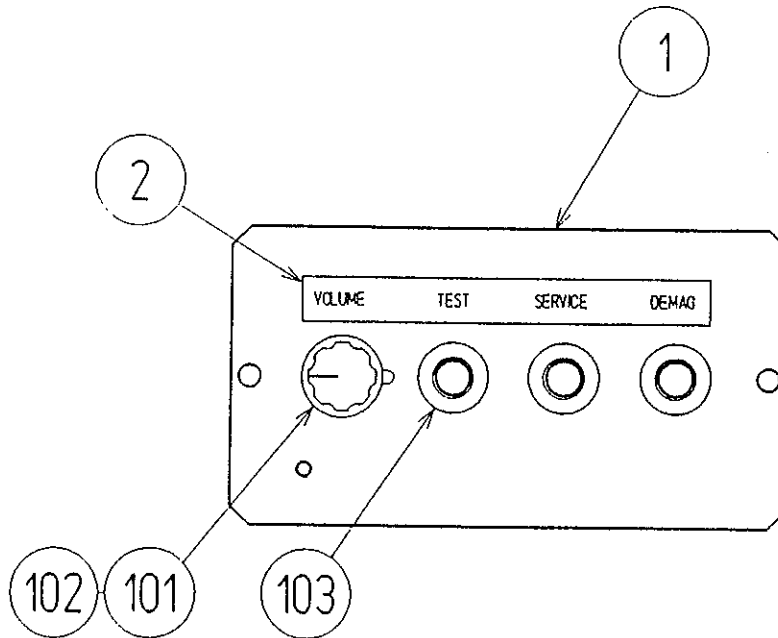

ITEM NO.	PART NO.	DESCRIPTION	NOTE
1	HOD-1541	SW PLATE	
2	421-9966	STICKER SW UNIT	
101	220-5179	VOL CONT B-5K OHM	
102	601-0042	KNOB 22 MM	
103	509-5028	SW PB 1M	
104	601-0460	PLASTIC TIE BELT 100 MM	
105	310-5029-015 512-5046-3000	SUMITUBE F D 15MM C.P 3000MA CE UL	TAIWAN OTHERS
301	600-6373-53	WIRE HARN TEST&SERVICE LEFT	
302	600-6373-55	WIRE HARN VOL. LEFT	

⑥ METER UNIT S (610-0395-01)

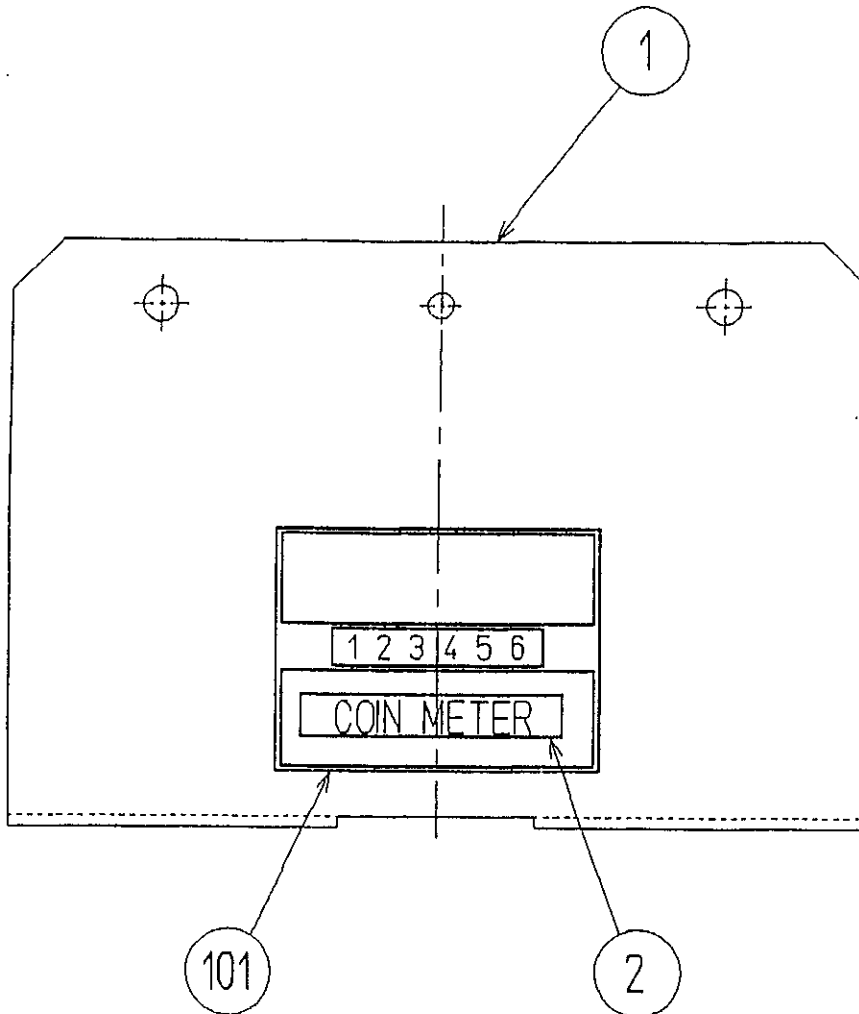

ITEM NO.	PART NO.	DESCRIPTION	NOTE
1	105-5233-01	METER BRKT S	
2	421-6591-01	STICKER COIN METER	
101	220-5412	MAG CNTR W/CONN	

⑦ AC UNIT (JPT-1540)

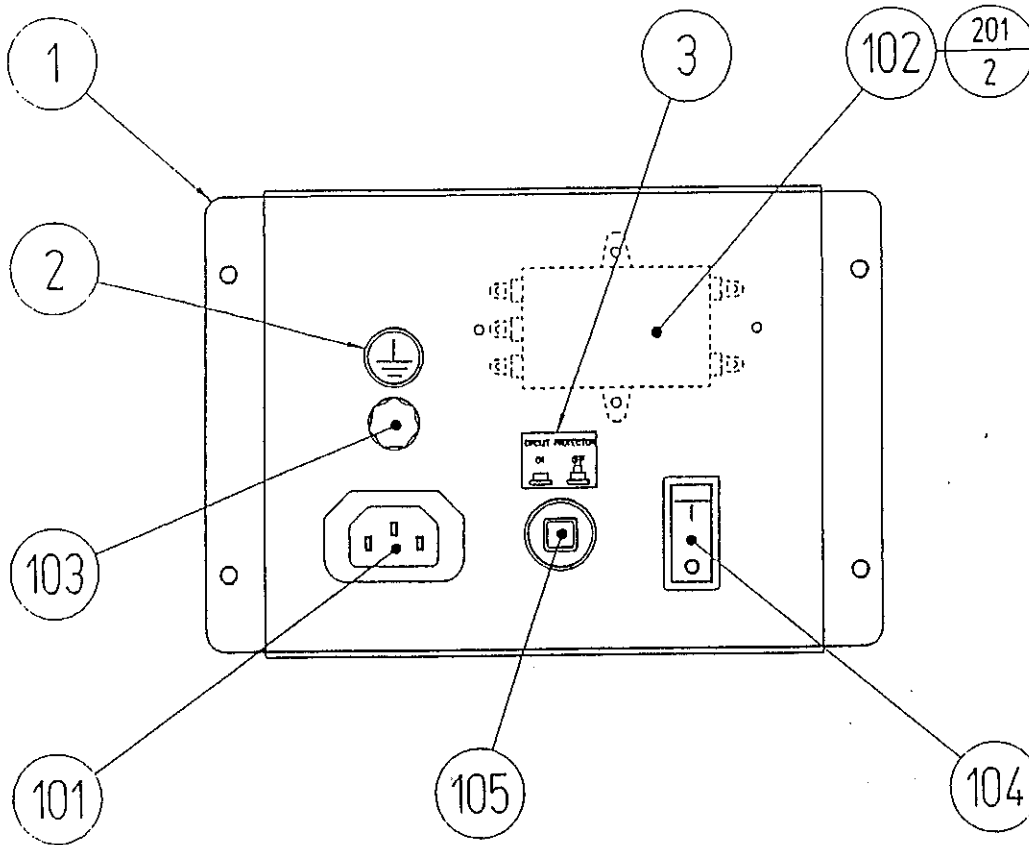

ITEM NO.	PART NO.	DESCRIPTION	NOTE
1	JPT-1541	AC BRACKET	
2	421-8202	STICKER EARTH MARK	
3	421-7468-02	STICKER C.P W/PIC	
101	214-0202	AC INLET PANEL TYPE	
102	270-5020	NOISE FILTER AC250V 6A	
103	280-0417	TERMINAL BINDING POST BLACK	
104	509-5453-V-B	SW ROCKER J8 V-B	
105	512-5046-5000	C.P 5000MA CE UL	
106	280-5009-01	CORD CLAMP 21	
107	601-0460	PLASTIC TIE BELT 100MM	
108	310-5029-F20	SUMI TUBE F F 20MM	
201	010-P00306-F	S-TITE SCR PH W/F M3 × 6	
301	600-6925-001	WIRE HARN C.P.	
302	600-6925-002	WIRE HARN N.FILTER IN	
303	600-6925-003	WIRE HARN N.FILTER OUT	
304	600-6925-043	WIRE HARN EARTH AC INLET	
305	600-6925-044	WIRE HARN EARTH AC UNIT	

⑧ ASSY SENSOR (HOD-1550)

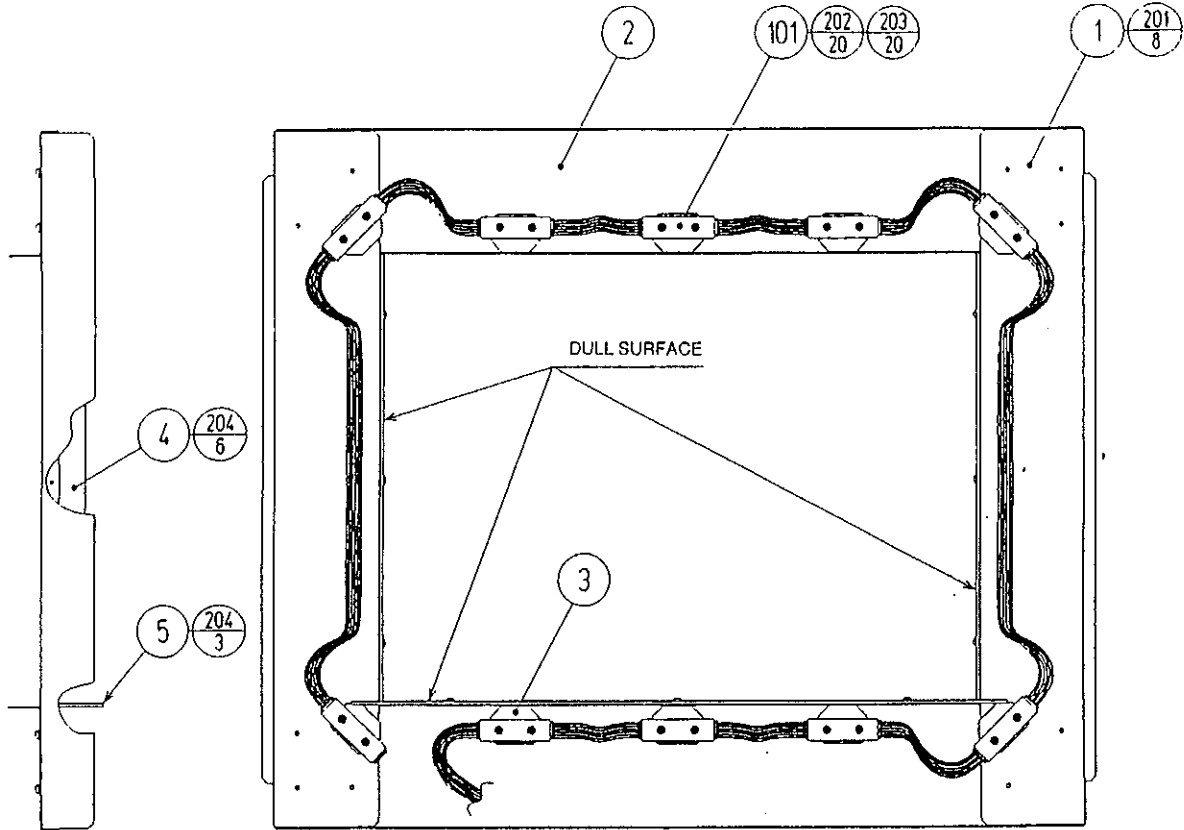

ITEM NO.	PART NO.	DESCRIPTION	NOTE
1	HOD-1551	SENSOR BRKT SIDE	
2	HOD-1552	SENSOR BRKT	
3	JPT-1082	IR COVER	
4	HOD-1553	MONITOR COVER SIDE	
5	HOD-1554	MONITOR COVER	
101	838-13145-02	LED BD GUN SENSE HOD	
102	280-5009-01	CORD CLAMP 21	
103	280-5275-SR10	CORD CLAMP SR10	
201	000-P00408-WB	M SCR PH W/FS BLK M4 × 8	
202	050-U00300	U NUT M3	
203	068-330808-PN	FLT WSHR PLASTIC 3.3-8 × 0.8	
204	000-T00408-0B	M SCR TH BLK M4 × 8	
301	600-6925-039	WIRE HARN LED BD A	
302	600-6925-040	WIRE HARN LED BD B	
303	600-6925-041	WIRE HARN LED BD C	
304	HOD-61008	WIRE HARN LED BD D	

⑨ ASSY MONITOR 29 31K (HOD-1570)

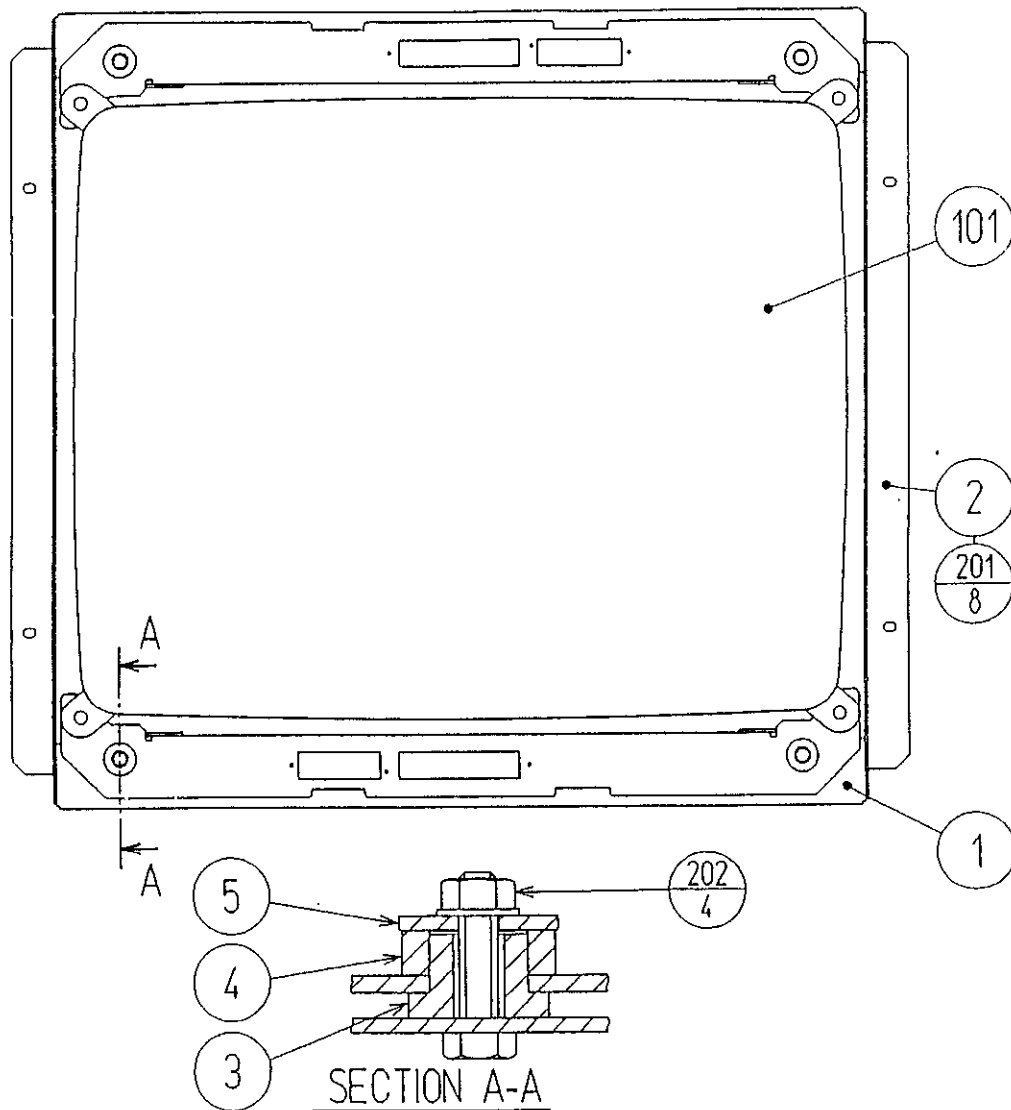

ITEM NO.	PART NO.	DESCRIPTION	NOTE
1	AIN-1026	MONITOR BRKT A	
2	AIN-1027	MONITOR BRKT B	
3	280-5112	BUSH FOR TV	
4	280-5113	COLLAR FOR TV	
5	280-5114	SPACER 6.4-25 × 2	
101	200-5787-01	ASSY CLR DSPL 29TYPE 31K MR	
201	000-P00512-W	M SCR PH W/FS M5 × 12	
202	050-F00600	FLG NUT M6	

⑩ ASSY CONT PNL U/R (HOD-2200)

(D-1/2)

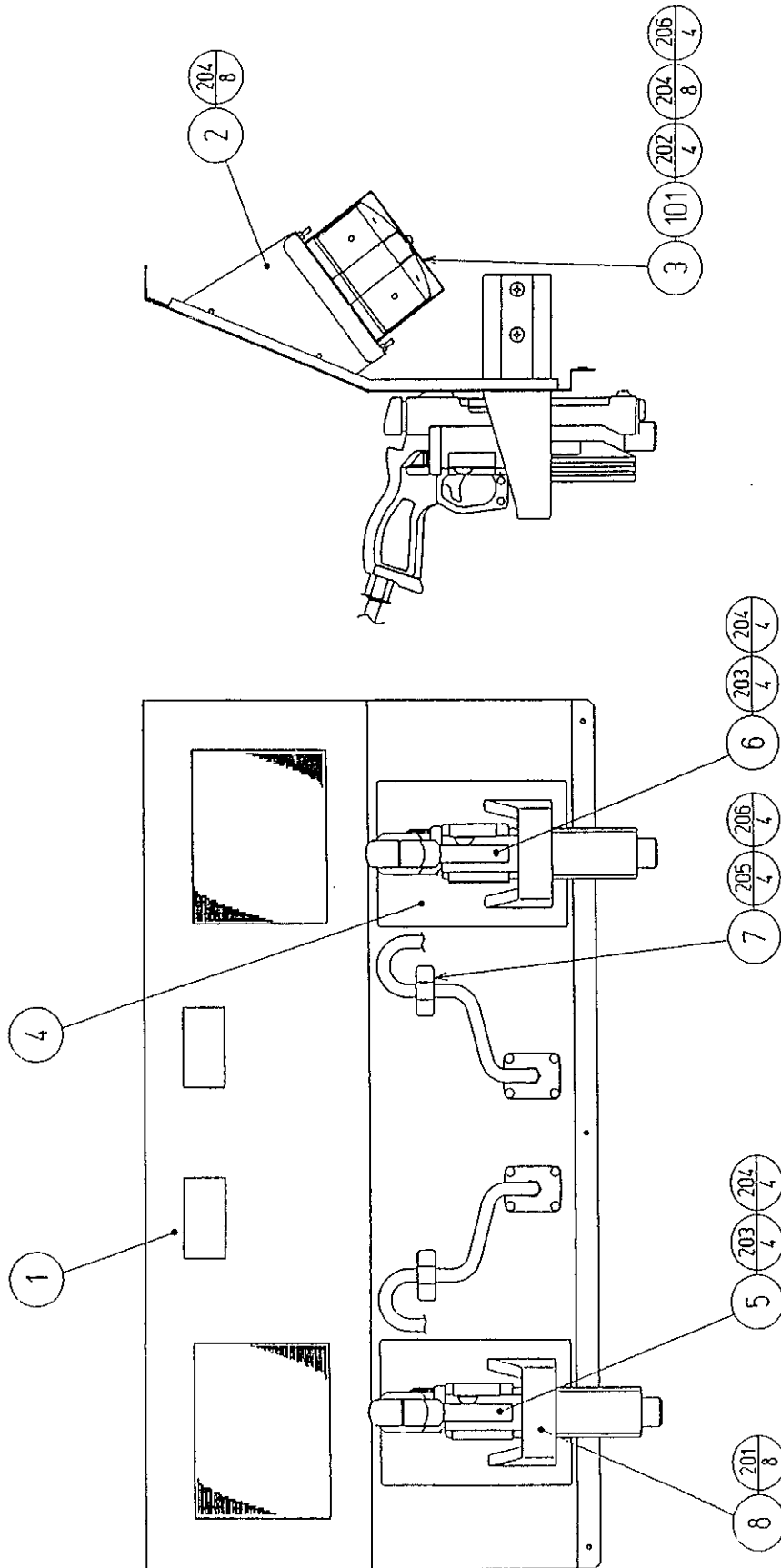

⑩ ASSY CONT PNL U/R (HOD-2200)

(D-2/2)

ITEM NO.	PART NO.	DESCRIPTION	NOTE
1	HOD-2201	CONT PNL BASE	
2	HOD-2202	SPEAKER BASE	
3	HOD-2203	SPEAKER HOLDER	
4	JPT-2204	PROTECT SHEET	
5	HOD-2250	CONTROL UNIT U/R 1P	
6	HOD-2260	CONTROL UNIT U/R 2P	
7	COP-2135	CABLE CLAMP DX	
8	CPT-1019	HOLDER	
101	130-5162	GULL BOX SPEAKER 80HM 8W	
102	280-5009-01	CORD CLAMP 21	
103	280-5275-SR10	CORD CLAMP SR10	
104	601-0460	PLASTIC TIE BELT 100 MM	
201	000-P00612-W	M SCR PH W/FS M6 × 12	
202	012-P00412	TAP SCR #2 PH 4 × 12	
203	031-000410-OC	CRG BLT CRM M4 × 10	
204	050-F00400	FLG NUT M4	
205	050-U00400	U NUT M4	
206	060-F00400	FLT WSHR M4	
207	000-P00410-W	M SCR PH W/FS M4 × 10	
301	600-6925-034	WIRE HARN EXT SW PANEL	
302	600-6925-036	WIRE HARN EXT SPEAKER B	
303	600-6925-046	WIRE HARN EARTH CONT PNL	

⑪ CONTROL UNIT U/R 1P (HOD-2250)

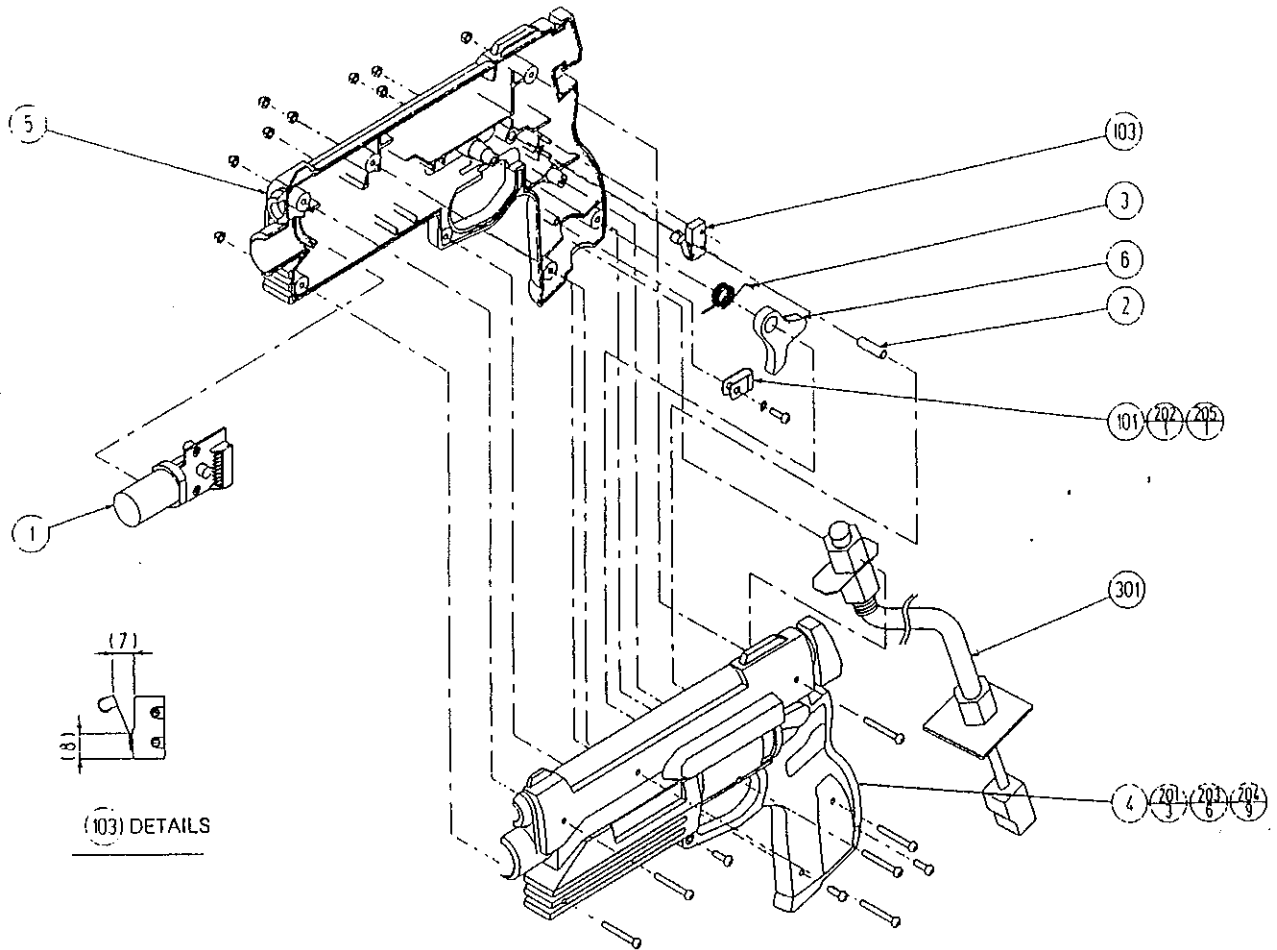

ITEM NO.	PART NO.	DESCRIPTION	NOTE
1	JPT-2030	SENSOR UNIT	
2	COP-2005	STOPPER PIN	
3	125-5124	TORSION SPRING	
4	253-5404-02	COVER LEFT RED	
5	253-5405-02	COVER RIGHT RED	
6	253-5406-02	TRIGGER RED	
101	280-5124-03	NYLON CLAMP NK03	
102	310-5029-D20	SUMITUBE F D 20 MM	
103	509-5080	SW MICRO TYPE	
104	601-0460	PLASTIC TIE BELT 100 MM	
201	000-P00308-0B	M SCR PH BLK M3 × 8	
202	012-P00308	TAP SCR #2 PH 3 × 8	
203	FAS-000015	M SCR PH BLK M3 × 25	
204	FAS-500006	CAP NUT TYPE 3 BLK M3	
205	060-F00300	FLT WSHR M3	
301	HOD-61009	WIRE HARN CONTROL UNIT 1P	

⑫ CONTROL UNIT U/R 2P (HOD-2260)

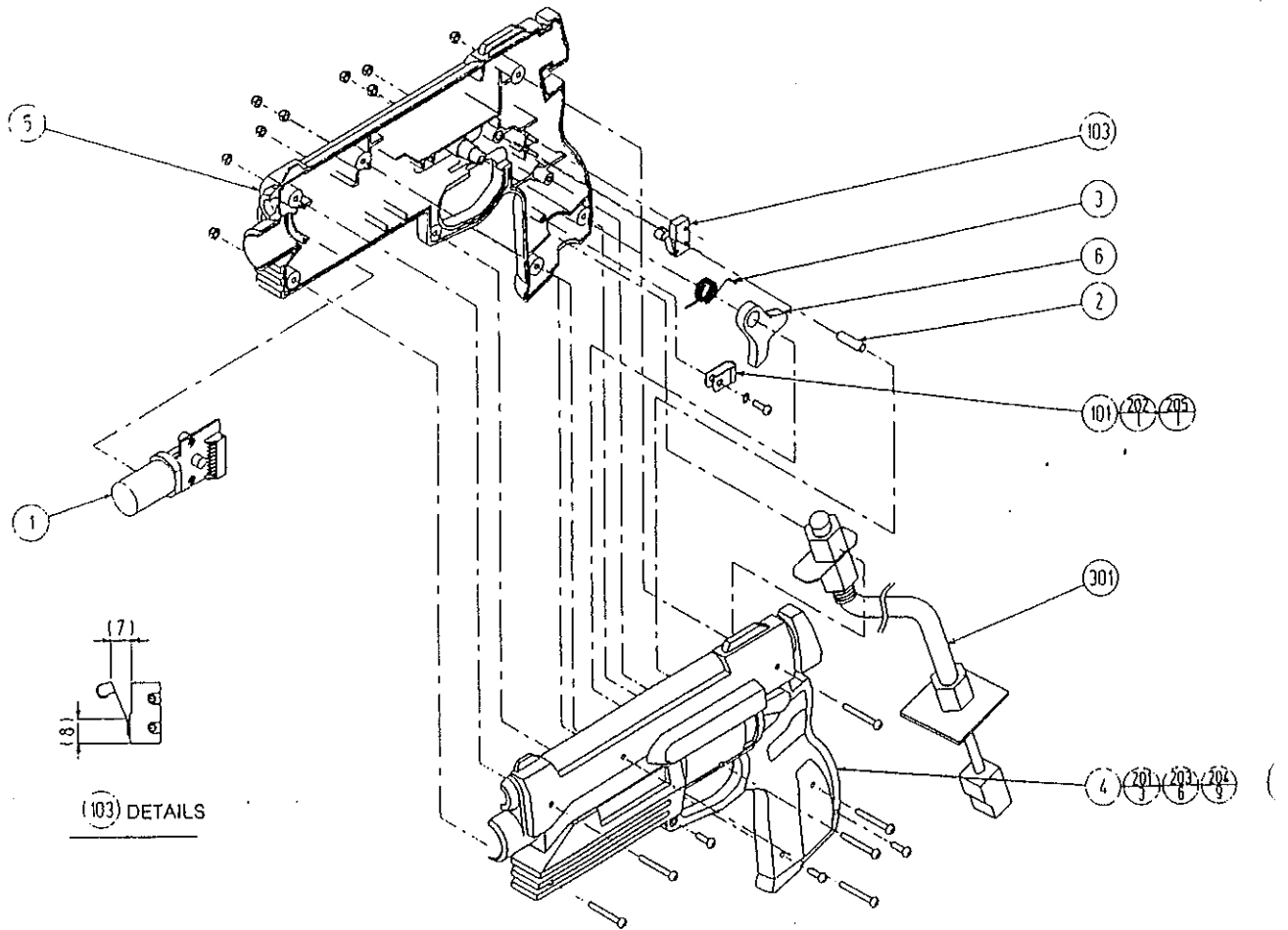

ITEM NO.	PART NO.	DESCRIPTION	NOTE
1	JPT-2030	SENSOR UNIT	
2	COP-2005	STOPPER PIN	
3	125-5124	TORSION SPRING	
4	253-5404-02	COVER LEFT RED	
5	253-5405-02	COVER RIGHT RED	
6	253-5406-02	TRIGGER RED	
101	280-5124-03	NYLON CLAMP NK03	
102	310-5029-D20	SUMITUBE F D 20 MM	
103	509-5080	SW MICRO TYPE	
104	601-0460	PLASTIC TIE BELT 100 MM	
201	000-P00308-0B	M SCR PH BLK M3 × 8	
202	012-P00308	TAP SCR #2 PH 3 × 8	
203	FAS-000015	M SCR PH BLK M3 × 25	
204	FAS-500006	CAP NUT TYPE 3 BLK M3	
205	060-F00300	FLT WSHR M3	
301	HOD-61010	WIRE HARN CONTROL UNIT 2P	

⑬ ASSY SW PANEL (HOD-2300)

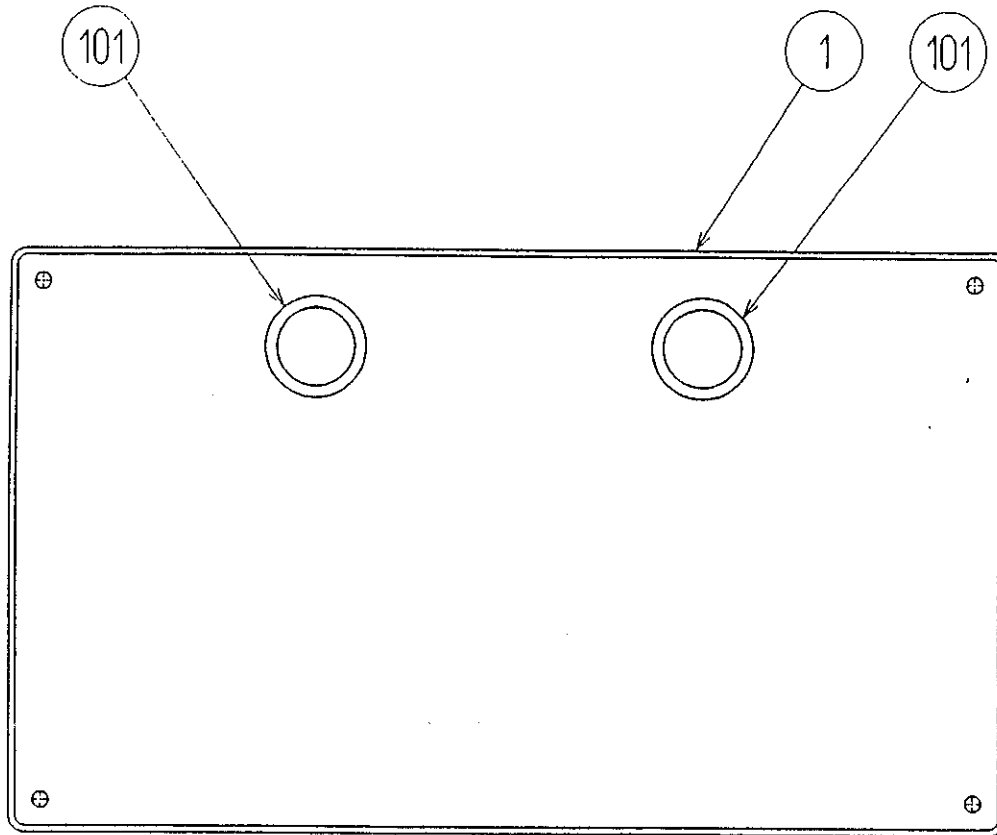

ITEM NO.	PART NO.	DESCRIPTION	NOTE
1	HOD-2301	INSTR PLATE HOD U/R	
101	509-5610-03YE	SW PB 30M YELLOW W/L WH 5V 3W	
301	600-6457-10	WIRE HARN START	
302	600-6457-36	WIRE HARN START EX	

14 ASSY BILLBOARD (HOD-3500)

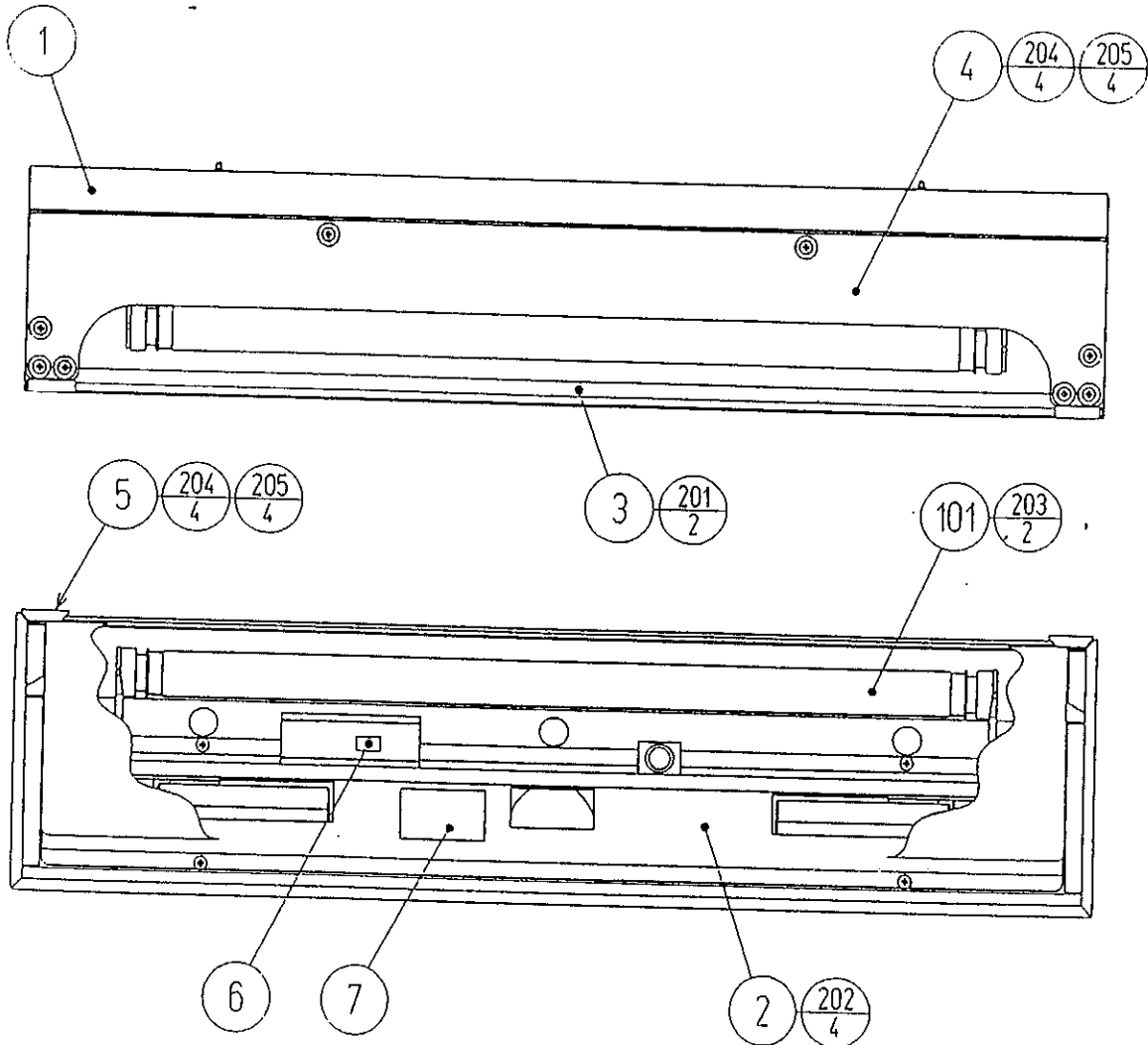

ITEM NO.	PART NO.	DESCRIPTION	NOTE
1	HOD-3501	BILLBOARD CASE	
2	JPT-3502	REFLECTOR	
3	JPT-3503	LAMP COVER A	
4	HOD-3504	LAMP COVER B	
5	HOD-3505	BILLBOARD UPPER SUSH	
6	421-7501-17	STICKER FL 20W	
7	440-WS0012XEG	STICKER W HIGH TEMP ENG	
101	390-5538-20SD	ASSY FL20W SD W/CONN HIGH L	
	390-5636-20SD	ASSY FL20W SD W/CONN HIGH S	
	390-5637-20SD	ASSY FL20W SD W/CONN HIGH T	
102	280-5275-SR10	CORD CLAMP SR10	
201	000-F00408-0B	M SCR FH BLK M4 x 8	
202	000-T00408-0B	M SCR TH BLK M4 x 8	
203	000-P00430-W	M SCR PH W/FS M4 x 30	
204	000-T00412-0B	M SCR TH BLK M4 x 12	
205	068-441616-0B	FLT WSHR BLK 4.4-16 x 1.6	
301	600-6925-035	WIRE HARN FL	

⑮ ASSY PWR SPLY U/R (HOD-4500)

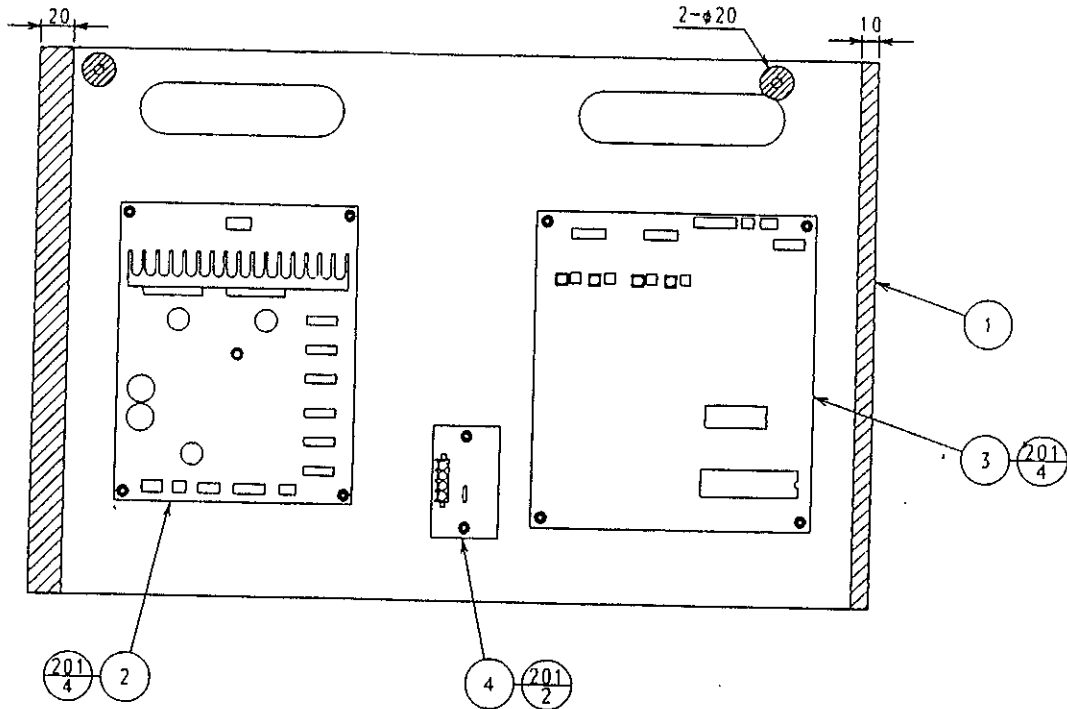

NOTE : MAKE SURE THAT THERE IS WIRING, ETC. IN THE SLASH MARK PORTIONS.

ITEM NO.	PART NO.	DESCRIPTION	NOTE
1	JPT-4501	PWR SPLY BASE U/R	
2	838-11650-29	EQ PWR AMP JPT C	
3	838-13143-04	IC BD GUN SENSE HOD UR	
4	839-0979	LAMP COVER B	
101	280-0419	HARNES LUG	
102	280-5009-01	CORD CLAMP 21	
103	601-0460	PLASTIC TIE BELT 100 MM	
104	601-10397-01	SLIONTEC AL TAPE 8060 200 × 240	
105	270-5052-04	L. FILTER D	
106	270-5117	FERRITE CORE TDK ZCAT3035-1330	
201	011-P00325	TAP SCR PH 3 × 25	
202	011-T03512	TAP SCR TH 3.5 × 12	
203	011-F00310	TAP SCR FH 3 × 10	
301	600-6925-007	WIRE HARN EQ. AMP AC IN	
302	600-6925-008	WIRE HARN EQ. AMP VR	
303	600-6925-009	WIRE HARN EQ. AMP SOUND IN	
304	600-6925-010	WIRE HARN EQ. AMP SPEAKER	
305	600-6925-014	WIRE HARN IC BD TO MAIN BD	
306	600-6925-015	WIRE HARN IC BD TO LED BD	
307	600-6925-048	WIRE HARN IC BD TO SENSOR	

①⑥ ASSY MAIN BD U/R (HOD-4600)

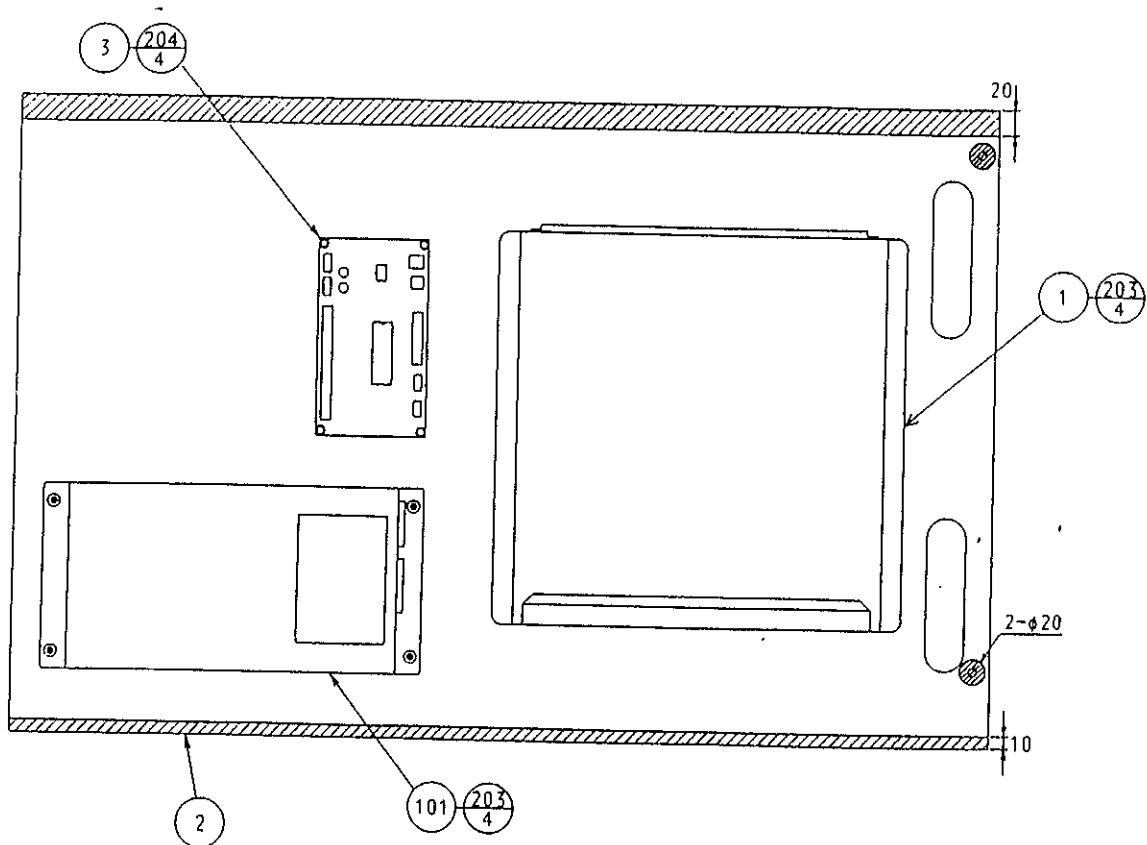

NOTE : MAKE SURE THAT THERE IS WIRING, ETC. IN THE SLASH MARK PORTIONS.

ITEM NO.	PART NO.	DESCRIPTION	NOTE
1	HOD-4200-01 HOD-4200-02 HOD-4200-03 HOD-4200-04	ASSY SHIELD CASE USA ASSY SHIELD CASE EXP ASSY SHIELD CASE KOR ASSY SHIELD CASE AUS	USA OTHERS KOREA AUSTRALIA
2	HOD-4601	MAIN BD BASE U/R	
3	837-13551	I/O CONTROL BD FOR JVS	
101	400-5330-03	SW REGU FOR MODEL3	
102	280-0419	HARNESS LUG	
103	280-5009-01	CORD CLAMP 21	
201	011-T03512	TAP SCR TH 3.5 × 12	
202	011-F00310	TAP SCR FH 3 × 10	
203	000-P00416-W	M SCR PH W/FS M4 × 16	
204	011-P00325	TAP SCR PH 3 × 25	
301	HOD-61001	WIRE HARN MAIN BD U/R01	
302	HOD-61002	WIRE HARN MAIN BD U/R02	
303	HOD-61003	WIRE HARN MAIN BD U/R03	
304	HOD-61004	WIRE HARN MAIN BD U/R04	
305	HOD-61006	WIRE HARN MAIN BD U/R05	
306	HOD-61007	WIRE HARN MAIN BD U/R06	
307	600-7141-100	CABLE JVS TYPE A-B 100CM	

①⑦ ASSY SHIELD CASE ~ (HOD-4200-01 ~ 04)

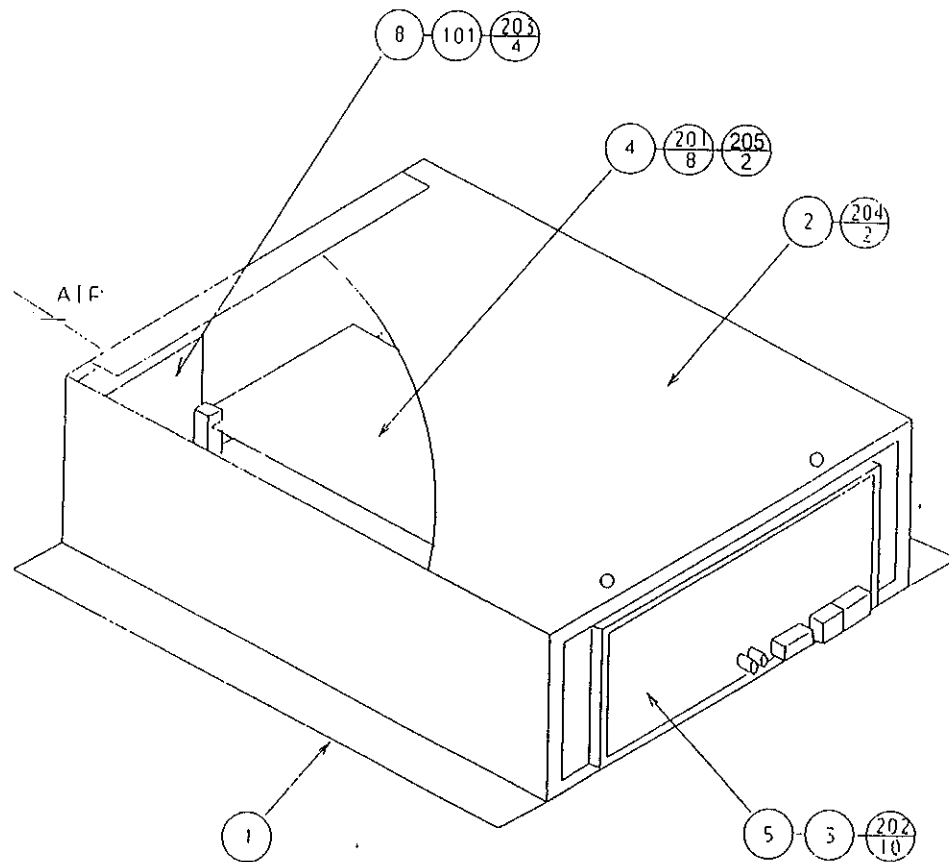

ITEM NO.	PART NO.	DESCRIPTION	NOTE
1	105-5345	SHIELD CASE NAOMI	
2	105-5346	SHIELD CASE LID NAOMI	
3	105-5347	FILTER BD BRKT NAOMI	
4	833-13635-01	GAME BD HOD USA	USA OTHERS KOREA AUSTRALIA
	833-13635-02	GAME BD HOD EXP	
	833-13635-03	GAME BD HOD KOR	
	833-13635-04	GAME BD HOD AUS	
5	839-1069	FLT BD NAOMI	
6	421-6510-136351	STICKER 833-13635-01	USA OTHERS KOREA AUSTRALIA
	421-6510-136352	STICKER 833-13635-02	
	421-6510-136353	STICKER 833-13635-03	
	421-6510-136354	STICKER 833-13635-04	
7	421-9174	STICKER CAUTION ANTISTATIC	
8	105-5351	FAN MOTOR BRKT NAOMI	
9	421-10023	STICKER BD SERIAL NUMBER	
10	601-10488	CARTON BOX NAOMI METAL	
101	260-0064	FAN MOTOR DC12V	
102	280-5275-SR10	CORD CLAMP SR10	
201	010-P00310-F	S-TITE SCR PH W/F M3 × 10	
202	010-P00306-F	S-TITE SCR PH W/F M3 × 6	
203	050-F00400	FLG NUT M4	
204	000-P00408-W	M SCR PH W/FS M4 × 8	
205	010-P00365-F	S-TITE SCR PH W/F M3 × 65	
301	HOD-60037	WIRE HARN FAN SHIELD CASE	

19. WIRE COLOR CODE TABLE

THE WIRE COLOR CODE is as follow:

A	PINK
B	SKY BLUE
C	BROWN
D	PURPLE
E	LIGHT GREEN

Wires other than those of any of the above 5 single colors will be displayed by 2 alphanumeric characters.

1	RED
2	BLUE
3	YELLOW
4	GREEN
5	WHITE
7	ORANGE
8	BLACK
9	GRAY

If the right-hand side numeral of the code is 0, then the wire will be of a single color shown by the left-hand side numeral (see the above).

Note 1: If the right-hand side alphanumeric is not 0, that particular wire has a spiral color code. The left-hand side character shows the base color and the right-hand side one, the spiral color.

<Example> 51 WHITE / RED

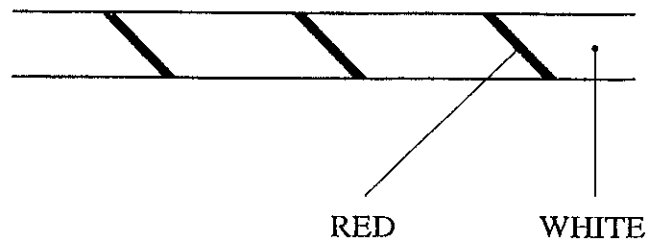

Note 2: The character following the wire color code indicates the size of the wire.

K:	AWG18, UL1015
L:	AWG20, UL1007
None:	AWG22, UL1007

THE HOUSE OF THE DEAD 2 DXタイプ、U/Rタイプ 取扱説明書正誤表

取扱説明書に誤りがありました。以下のように訂正いたします。

● 9-2③ (DXは35、36ページ。U/Rは29、30ページ)

(D) の文章と表1を以下に変更します。

(D) COIN/CREDIT SETTING (#1~#27)

コイン投入に対するクレジットの増加分を設定します。設定は#1から#27まであり、(Y)枚のコインを入れたときに、〇〇クレジットになるという表わし方をしています。ただし、#27はFREE PLAYとなります。

詳しい表示は表1(COMMON)を参照ください。

表1 COIN/CREDIT SETTING (COIN CHUTE COMMON TYPE)

設定番号	コイン1の動作		コイン2の動作	
SETTING #1	1 COIN	1 CREDIT	1 COIN	1 CREDIT
SETTING #2	1 COIN	2 CREDITS	1 COIN	1 CREDIT
SETTING #3	1 COIN	3 CREDITS	1 COIN	1 CREDIT
SETTING #4	1 COIN	4 CREDITS	1 COIN	1 CREDIT
SETTING #5	1 COIN	5 CREDITS	1 COIN	1 CREDIT
SETTING #6	1 COIN	2 CREDITS	1 COIN	2 CREDITS
SETTING #7	1 COIN	5 CREDITS	1 COIN	2 CREDITS
SETTING #8	1 COIN	3 CREDITS	1 COIN	3 CREDITS
SETTING #9	1 COIN	4 CREDITS	1 COIN	4 CREDITS
SETTING #10	1 COIN	5 CREDITS	1 COIN	5 CREDITS
SETTING #11	1 COIN	6 CREDITS	1 COIN	6 CREDITS
SETTING #12	2 COINS	1 CREDIT	2 COINS	1 CREDIT
SETTING #13	1 COIN	1 CREDIT	2 COINS	1 CREDIT
SETTING #14	1 COIN	2 CREDITS	2 COINS	1 CREDIT
SETTING #15	1 COIN	1 CREDIT	1 COIN	1 CREDIT
	2 COINS	3 CREDITS	2 COINS	3 CREDITS
SETTING #16	1 COIN	3 CREDITS	1 COIN	1 CREDIT
			2 COINS	3 CREDITS
SETTING #17	3 COINS	1 CREDIT	3 COINS	1 CREDIT
SETTING #18	4 COINS	1 CREDIT	4 COINS	1 CREDIT
SETTING #19	1 COIN	1 CREDIT	1 COIN	1 CREDIT
	2 COINS	2 CREDITS	2 COINS	2 CREDITS
	3 COINS	3 CREDITS	3 COINS	3 CREDITS
	4 COINS	5 CREDITS	4 COINS	5 CREDITS
SETTING #20	1 COIN	5 CREDITS	1 COIN	1 CREDIT
			2 COINS	2 CREDITS
			3 COINS	3 CREDITS
			4 COINS	5 CREDITS
SETTING #21	5 COINS	1 CREDIT	5 COINS	1 CREDIT
SETTING #22	1 COIN	2 CREDITS	3 COINS	1 CREDIT
			5 COINS	2 CREDITS
SETTING #23	2 COINS	1 CREDIT	2 COINS	1 CREDIT
	4 COINS	2 CREDITS	4 COINS	2 CREDITS
	5 COINS	3 CREDITS	5 COINS	3 CREDITS
SETTING #24	1 COIN	3 CREDITS	2 COINS	1 CREDIT
			4 COINS	2 CREDITS
			5 COINS	3 CREDITS
SETTING #25	1 COIN	1 CREDIT	1 COIN	1 CREDIT
	2 COINS	2 CREDITS	2 COINS	2 CREDITS
	3 COINS	3 CREDITS	3 COINS	3 CREDITS
	4 COINS	4 CREDITS	4 COINS	4 CREDITS
	5 COINS	6 CREDITS	5 COINS	6 CREDITS
SETTING #26	1 COIN	6 CREDITS	1 COIN	1 CREDIT
			2 COINS	2 CREDITS
			3 COINS	3 CREDITS
			4 COINS	4 CREDITS
			5 COINS	6 CREDITS
SETTING #27	FREE PLAY		FREE PLAY	

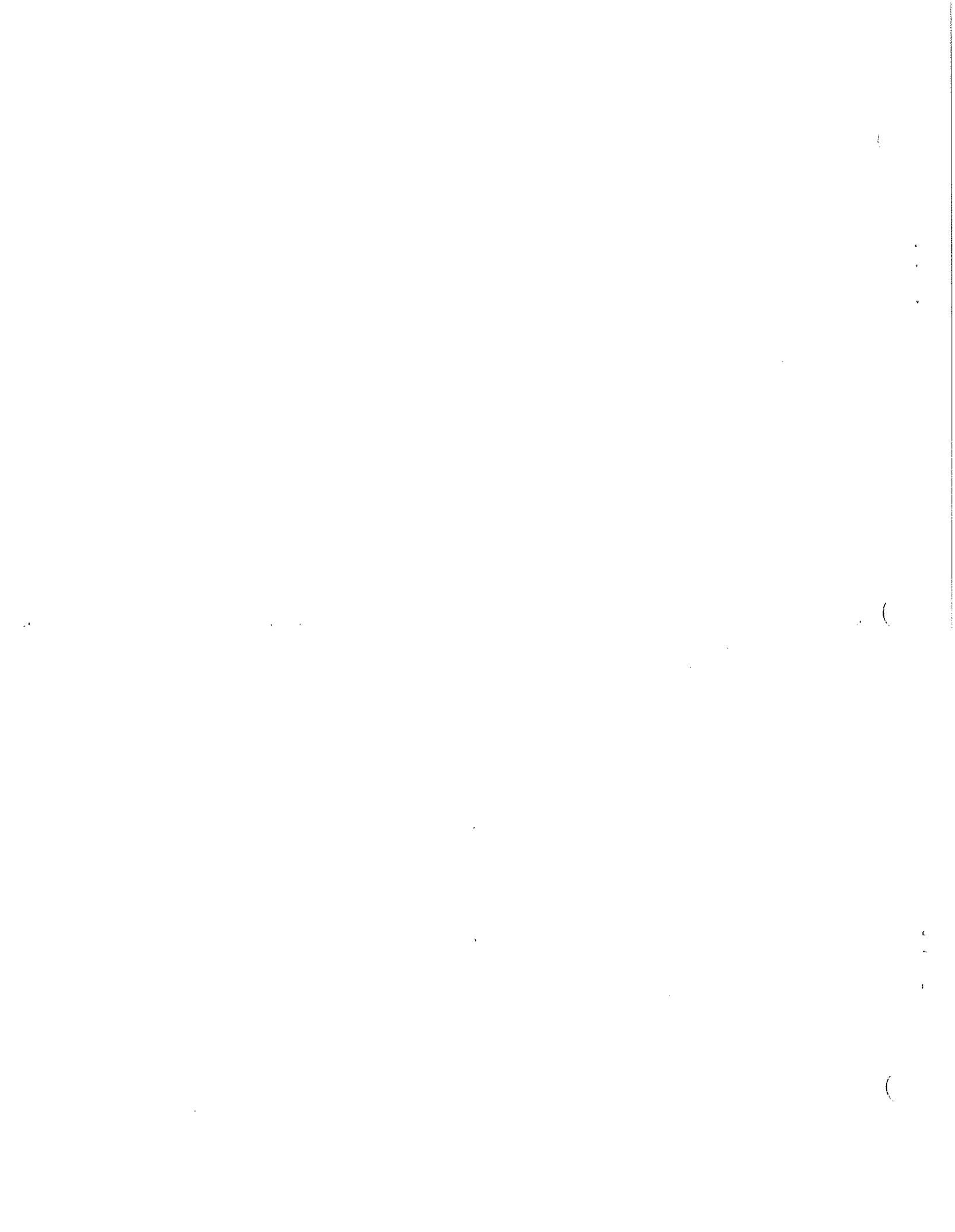

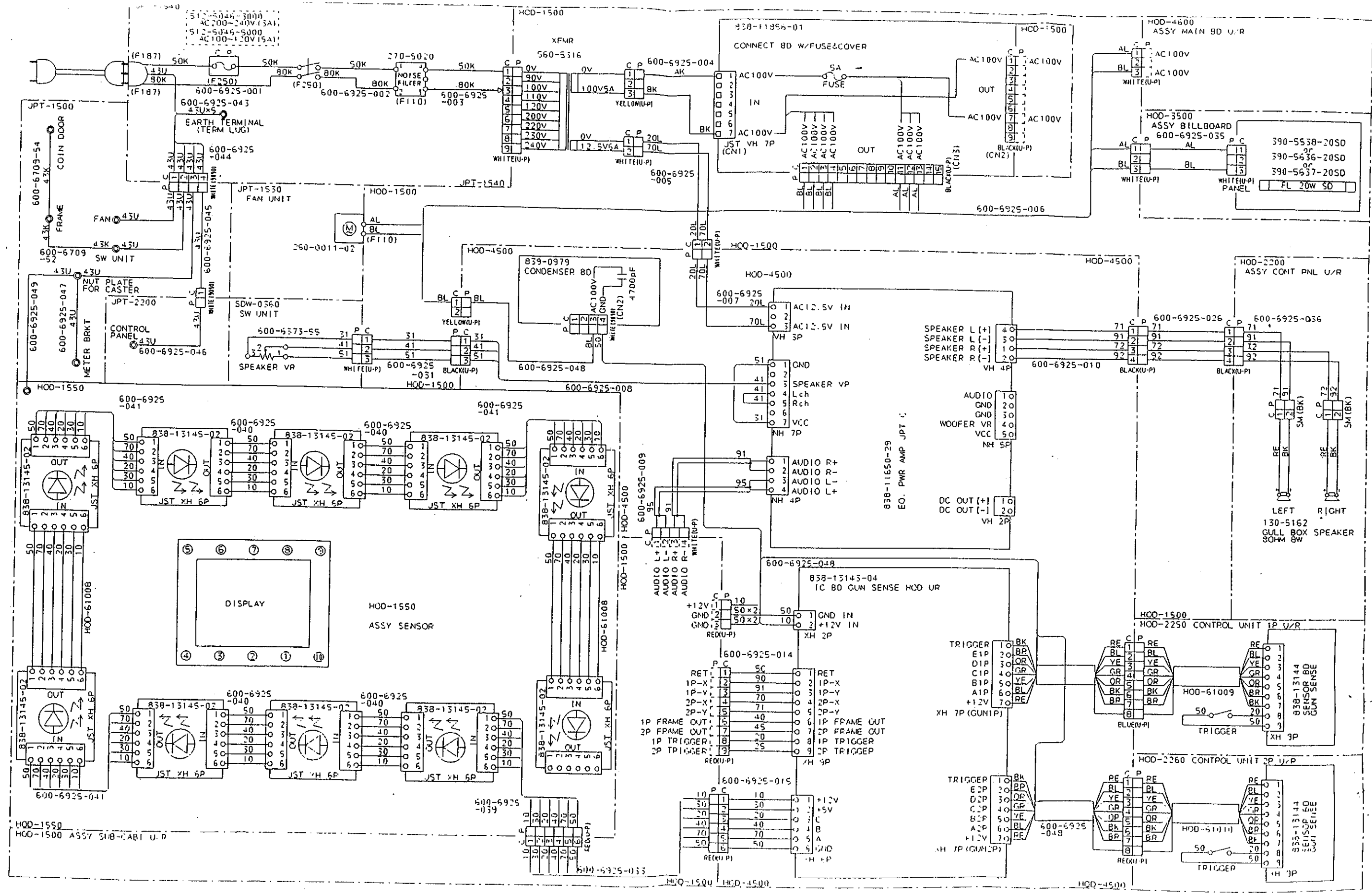

20. WIRING DIAGRAM (D-1/2)

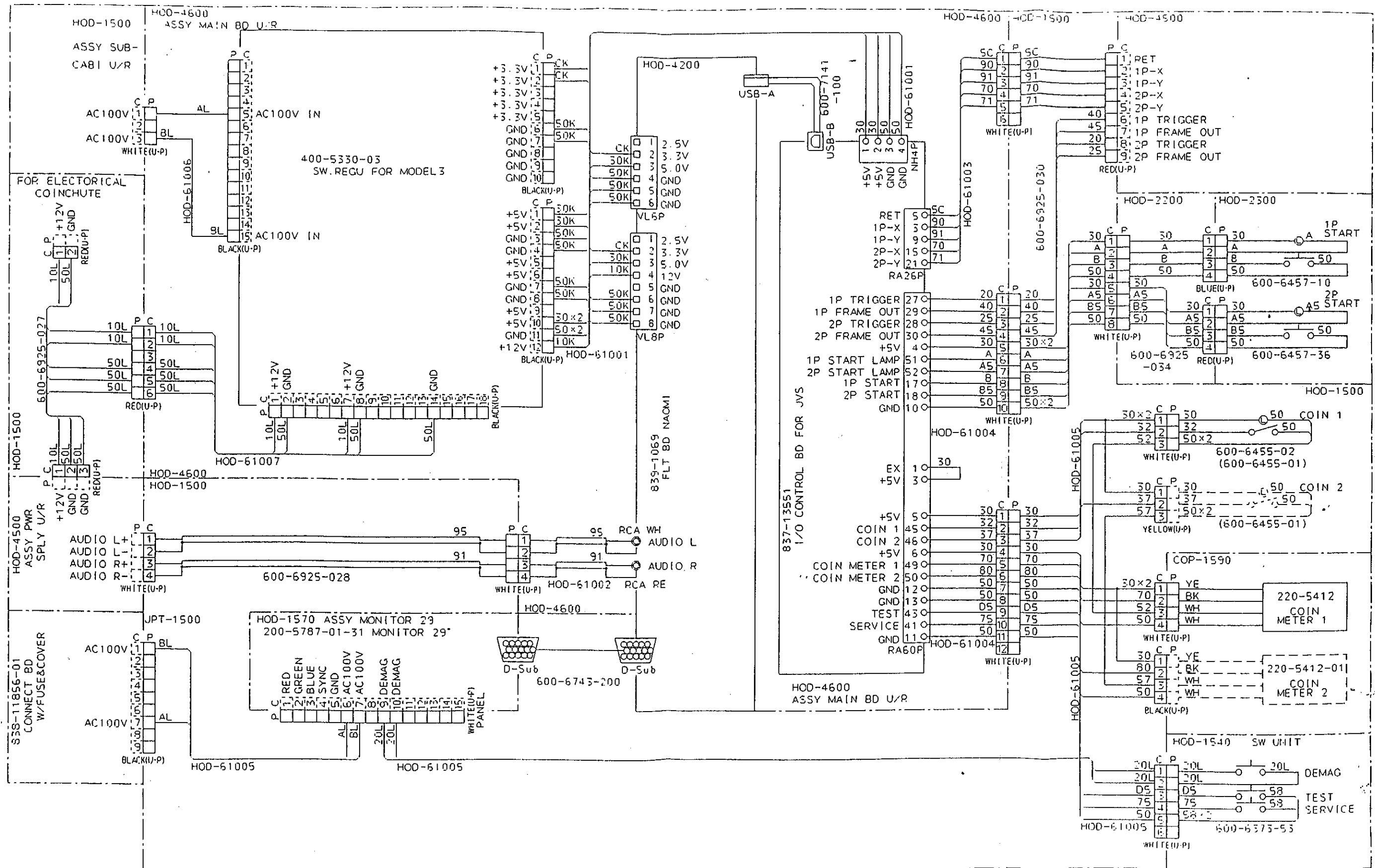

20. WIRING DIAGRAM (D-2/2)