



WORLD'S PREMIER GAMES

888-538-1000
 TEL (561) 588-5200
 FAX (561) 493-2999
 PARTS: (561) 493-3295 SERVICE: (561) 588-8446

51 Hypoluxo Rd.
 Hypoluxo, FL 33462-4501
 www.benchmarkgames.com

BIG RIG TRUCKIN'



**PLEASE READ FIRST BEFORE
 PLUGGING IN MACHINE**

21MAN-B

ALL RIGHT RESERVED. PAT. PENDING



Table of Contents

Game Set Up	3-4
General Game Play	5
Payout Percentage	6
Troubleshooting Guide	6-9
Truck will not dump when dump lever is hit.....	6
Bonus Target not paying out.....	7
Bonus Target Display not working.....	7
Dump Lever hit too easily.....	8
Coins are too low to enter Bonus Targets.....	8
Tickets pay out on complete misses.....	9
Service Instructions	10-13
Removing Top Glass.....	10
Replacing Playfield Light Bulbs.....	10
Replacing a Dump Motor.....	11
Adjusting Coin Ramp Height.....	11
Changing a Bonus Display Board.....	12
Changing a Bonus Opto Sensor.....	13
Programming Procedure	13
Programming Options	14
Wiring Diagrams and Schematics	16-25

Game Set Up

1. Bolt games together

- Remove top glass from game (see Removing Top Glass in Service Instructions section for directions).
- Remove (2) U-Channels① from back of game.
- Remove (2) Back Panels② from game by removing (12) Back Panel Screws③.
- Set games together aligning (3) bolt holes.
- Use supplied (3) Cabinet Bolts④ to bolt sides together. Two bolts are accessible from the front and one from the back of the game.
- Connect left and right cabinet harnesses⑤ together.

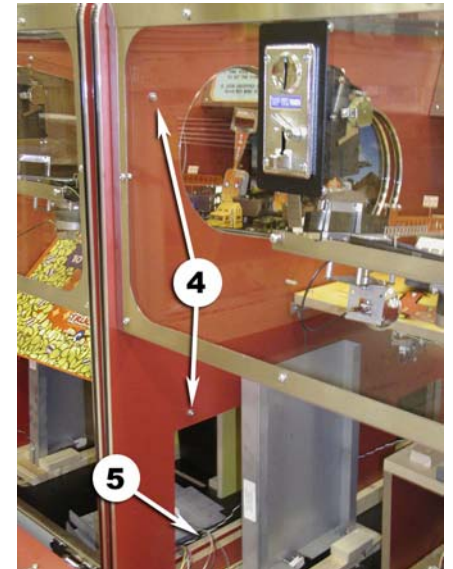
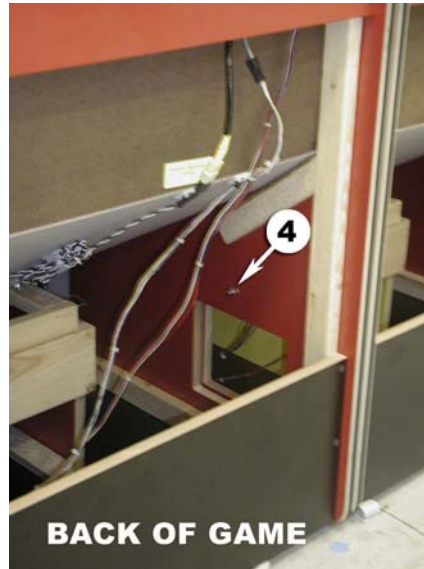

2. Mount Marquee

- Use supplied bolts and U-channel Brackets① to mount Marquee Box② to the back of the game.
- Fasten marquee harness with Harness Clips③ inside U-channel Brackets① and through hole in back of game and connect to the main harness.

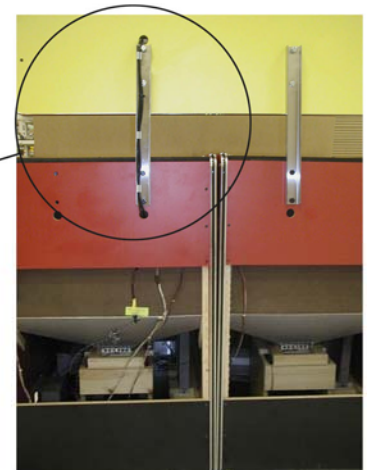
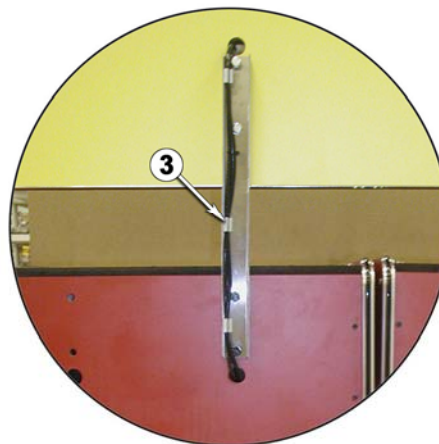
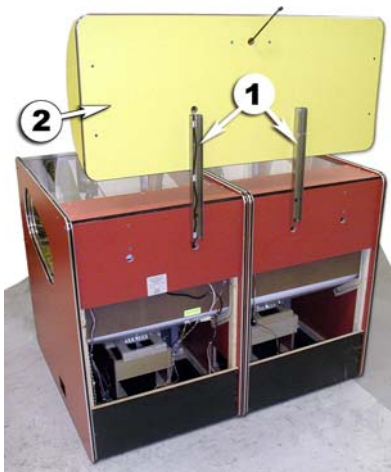

3. Mount Speaker Box

- a. Mount Speaker Bracket① to the back of the Marquee Box②.
- b. Connect speaker harness.
- c. Mount Speaker Box③ to Speaker Bracket① leaving the connector inside the box so it is not accessible.

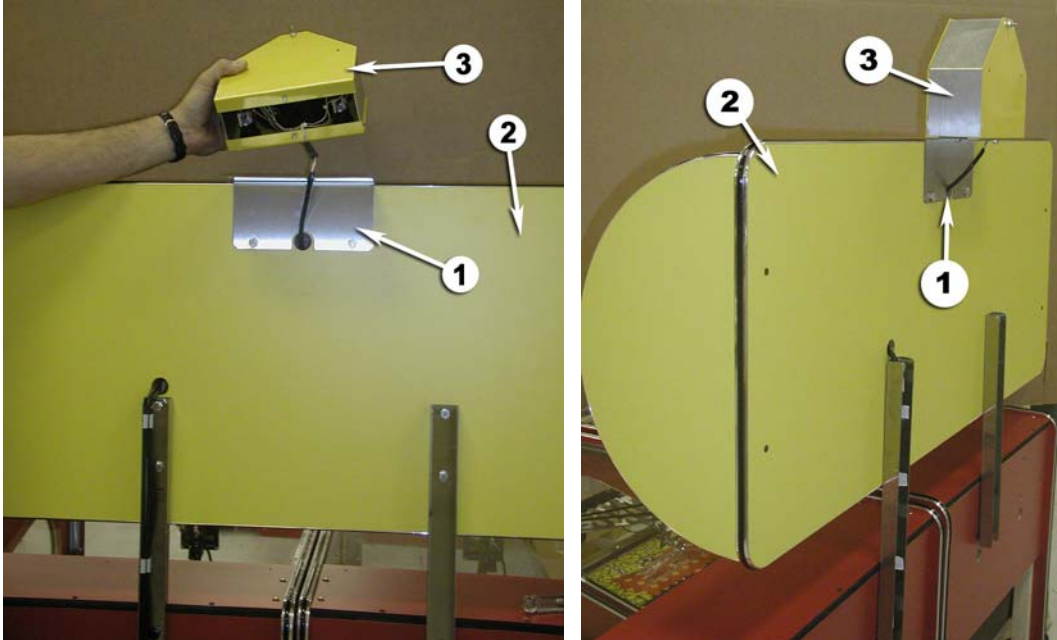

4. Seed Trucks

- a. Add 15 coins to each of the eight Truck Beds.



General Game Play

Big Rig Trucking is a fast coin roll down game. It is a two-player game and each side of the game plays independently. The player times his coin drop, aiming to score. The coin ramp moves back and forth continuously. There are four trucks, and three bonus targets. Each Bonus Target contains a display, which shows the ticket value of that target. There will always be one target with a larger value than the other two. This value randomly moves among the three targets. The large target value builds to the maximum Bonus Target Value and then rolls over to the minimum value before building again. This roll over is not a result of a win as would be the case with a standard progressive style jackpot. The value constantly scrolls up in value until the maximum value is reached and then returns to the minimum value.

The player can score one of three ways with each coin:

1. **Fill the truck**-Each time a coin lands in one of the trucks, the player is awarded a programmable number of tickets (5 tickets default).
2. **Dump the Truck**-When a coin hits one of the four dump levers, the corresponding truck is dumped. The player is awarded a programmable value per coin (10 tickets default). *Note:* The dump lever must be completely pushed back for the player to score a dump.
3. **Hit a Bonus Target**-When the coin rolls through one of the three bonus targets, the player is awarded the number of tickets displayed on that target at that moment.

Payout Percentage

Before adjusting the payout percentage, several weeks of payout average should be realized. It is normal to see large swings in payout percentage within short collection periods. A long-term average should be looked at before adjusting.

The payout percentage for the Big Rig can be adjusted by changing programmable values. For maximum revenue we recommend leaving the default settings. We Programming Procedure section for programming options.

Troubleshooting Guide

Please note that the Benchmark Games circuit boards are very reliable and electrically well protected. If there is a problem with the game, it is likely not a pcb. Verify connections, switches, mechanical operation, etc., before assuming a pcb problem.

Problem:

Truck Will Not Dump When dump lever is hit

Narrow the problem down:

- If the dump switch is hit and you get a “stand clear” sound, the switch is good, you have another problem
- None of the four trucks within one side of the cabinet dump
 - The dump motors and switches are probably OK. This symptom indicates that there is probably a loss of 5 Volts to the motors or a problem with a connection between the dump motor harness and the main controller board. Less likely, but possible is a bad main controller board. First check for 5 volts to all of the motors. If OK, check the dump motor switch signal at the board. If you do not get a good signal there, work up through the harness until you find the open connection. If you are getting a good signal at the controller board, the controller board is probably bad.
- One of the four trucks does not dump, but the corresponding dump motor runs
 - If a dump switch is hit and the motor runs but the truck does not dump, the switch and wiring are OK. The problem is either the Dump Linkage① or a bad Dump Motor Assembly②. Check to see if the Dump Linkage① is properly connected. If the linkage seems OK, the problem is the Dump Motor Assembly②. A motor assembly can be destroyed if there is something “jammed”, preventing the dump bed from dumping. Before replacing the motor, remove the linkage at the Motor Cam③ and check to make sure the Dump Bed④ moves freely.
- One of the four trucks does not dump and the corresponding dump motor does not run
 - The Main Controller PCB is probably OK. This problem is probably a result of loss of 5 Volts to the motor or a bad Dump Switch⑤ or the wiring for the associated Dump Motor Switch. First check for 5 Volts between the red wire on the motor and ground. If OK, check the switch and the wire from the switch to the main harness. If the switch and wiring seem OK, it could be the motor. You can do a quick motor check by switching the connection from the bad Dump Motor Assembly② or to the main harness with a main harness connection to a working motor.
- One of the trucks dumps continuously
 - This symptom is the result of a bad Cam Switch⑥ or the associated wiring. It could also be that the switch is good, but for some reason it is not switching in the Cam Detent⑦. Check the Cam Switch⑥ and the wiring. Make sure the switch is electrically switching in the Cam Detent⑦.

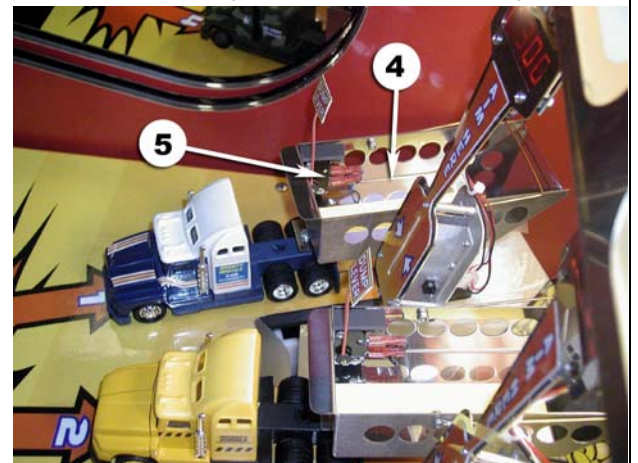
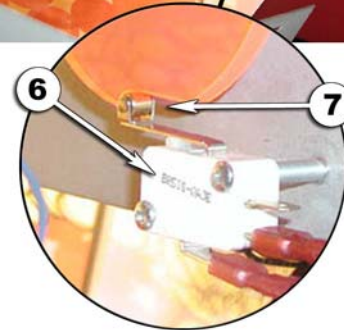
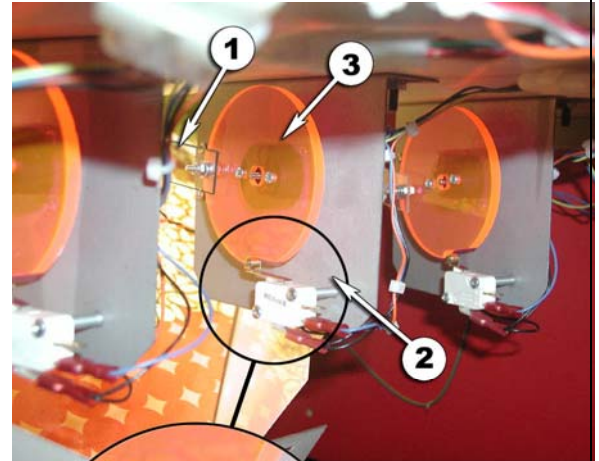

Bonus Target not paying out

- Check to be sure the Opto Sensor Board① is working by positioning an opaque material through the Target Slot② and within the 'horseshoe' of the sensor and look for the Opto LED③ to come on. You can ***use a mirror behind the Target Assembly***④ ***to look for the Opto LED***③.
 - If the LED comes on, there is probably a bad signal connection between the Opto Sensor Board① and the main controller board or a bad Opto Sensor Board. Check for a low transition at the main output of the Opto Sensor Board① when the Opto LED③ on the Opto Sensor Board① is on. If you get a low signal here, trace the signal to the main controller board looking for an open in the harness. If you get a low signal all of the way to the main controller board, the main controller board is probably bad
 - If the Opto LED③ does not come on, check voltage and ground to the Opto Sensor Board①. If voltages look OK, you probably have a bad Opto Sensor Board①.

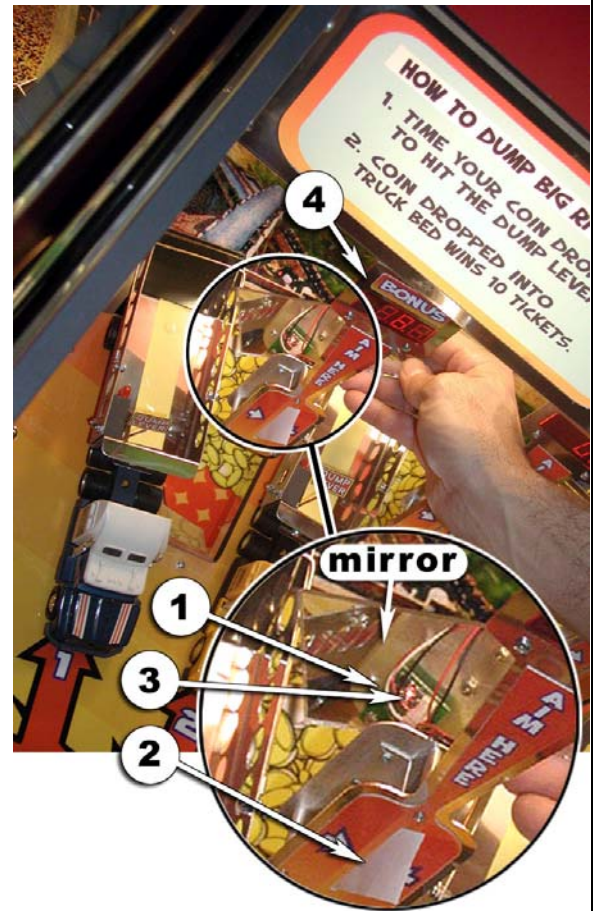

Bonus Target Display not working

- Check voltages and wiring at the Target Display Board①. If OK, try to plug another display into the same connector to verify a bad board.
- Verify Correct dip switch setting. See "Changing a Bonus Display Board" in the Service Instructions section for details.

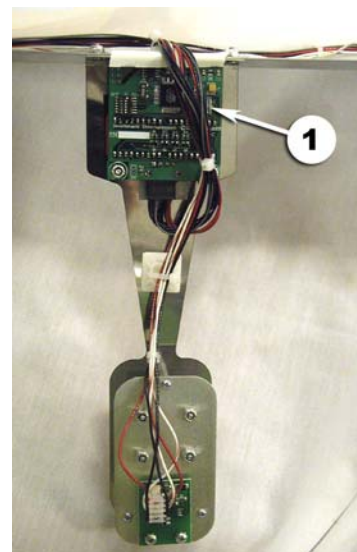

Rear View of Bonus Target

Dump lever hit too easily

- Check the height of the coin when it rolls off of the Coin Ramp① and past the Dump Lever Flag②. It should not be possible for the coin to contact the Dump Lever Flag②. To dump the truck, the coin must hit the Dump Lever Mast③, under the Dump Lever Flag②.
 - If it is possible for the coin to hit the Dump Lever Flag②, the Coin Ramp Bracket needs to be adjusted. See Adjusting Coin Ramp Height in the Service Instructions section.

Coins are too low to enter the Bonus Targets

- Either the Bonus Target(s)④ are bent back out of range of the coin, or the Coin Ramp Bracket needs adjustment.
 - Refer to Adjusting Coin Ramp Height in the Service Instructions section to verify that the coin ramp is set at the proper height. If the problem still exists, try carefully bending the Bonus Targets④ forward toward the front of the game.

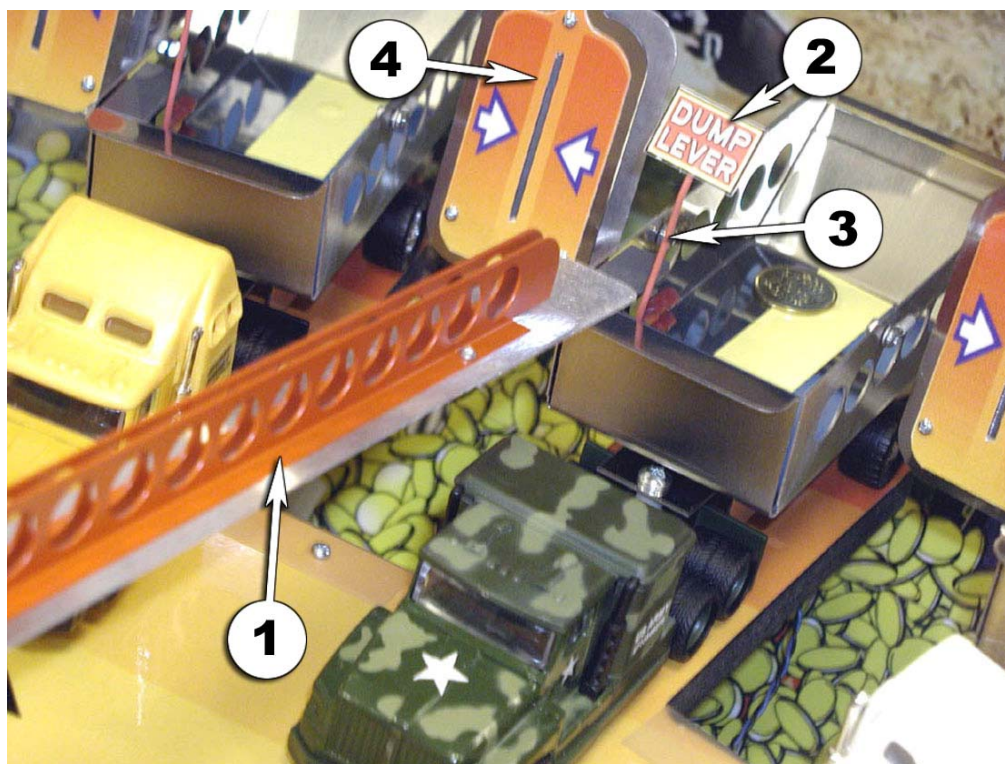

Tickets pay out on complete misses

- Mercy ticket option is active or
- Problem with Coin Chute Sensor Assembly①.
Note: it may be necessary to remove the Coin Chute Sensor Assembly① in order to perform all of the troubleshooting tips.

1. Check for Mechanical Problem

- Push the Coin Plate② back toward the front of the game. The Opto LED③ should light up. If it does not, check if the screw mounted to the coin plate is breaking the opto beam. If it is not, check the coin plate to make sure it is mounted properly and moving freely. Check the screw position to be sure it is centered in the opto path. You can adjust the alignment between the Opto Screw④ and the Opto Sensor Board⑤ by loosening the two sensor mount screws⑥ and moving the Opto Sensor Board⑤ up or down vertically before retightening.

2. Check for Electrical Problem

- Check to see if the Opto Sensor Board⑤ is working by interrupting the opto by positioning something opaque in the "Horseshoe"⑦ part of the sensor and watch to see if the Opto LED③ goes on.
 - i. If it does not, check ground and voltage to the board. If ground and voltage are good, the board is probably bad.
 - ii. If the Opto LED③ goes on, check to see if the output of the Opto Sensor Board⑤ is transitioning low when the opto is interrupted. If it is not going low, the board is bad. If it is transitioning low, you have a bad connection between the Opto Sensor Board⑤ and the main controller board or the main controller board is bad.

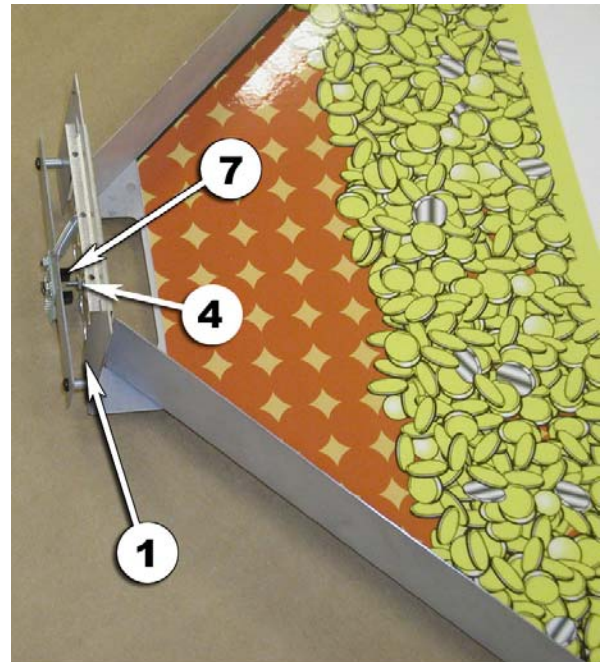
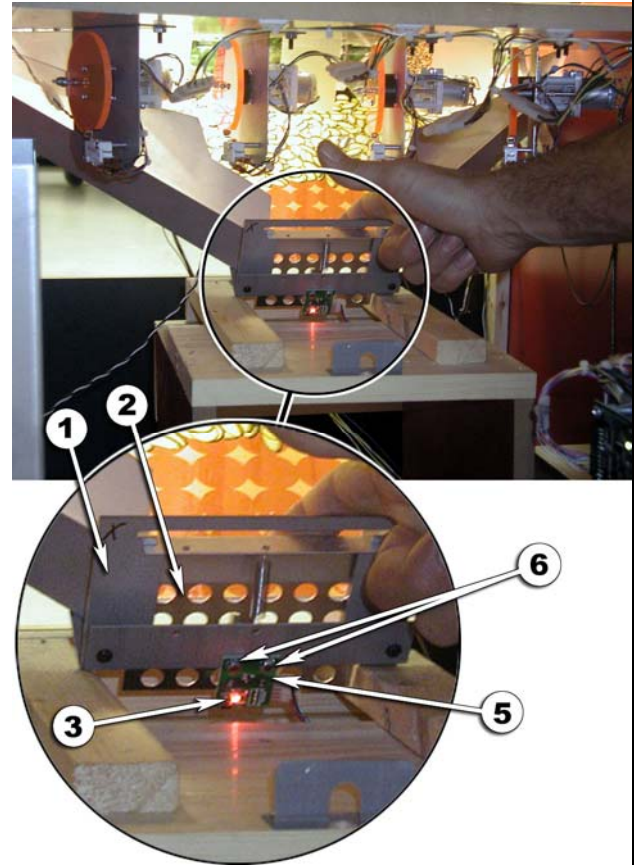

Shown with coin chute assembly removed from game

Service Instructions

Removing Top Glass

1. Open front door of cabinet
2. Remove Playfield Cover①
3. Reach up and slide Release Knob② to the right
4. Pull Glass Capture Bracket③ back to remove.
5. Remove Top Glass.

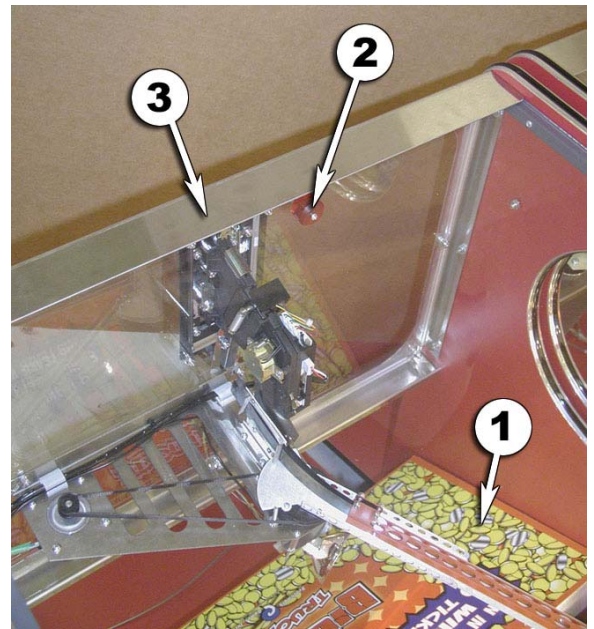

Replacing Playfield Light Bulbs

1. Power game OFF.
2. Reach underneath Instruction Plate① to access light bulbs-Replace with 30 Watt screw in fluorescent bulbs.



Replacing a Dump Motor

1. Remove the Dump Linkage Nut① to free the Dump Linkage Arm②
2. Remove (2) Motor Assembly Mounting Nuts③ and remove the Motor Assembly④
3. Remove the Dump Cam⑤ by removing (2) Cam Mount Screws⑥
4. Replace the Dump Cam⑤ on the new Motor Assembly④ so that the Cam Switch Roller⑦ sits in the Cam Detent⑧. If the Cam Switch Roller⑦ does not sit in the detent, remove the Dump Cam⑤ and reinstall it turned 180 degrees. **Do not attempt to turn the cam while it is assembled on the motor as you will destroy the assembly.**
5. Install new Motor Assembly④ leaving mount screws loose and reconnect Dump Linkage Arm②.
6. Adjust motor location.
 - a. Locate the Dump Bed on the truck in the down position.
 - b. Tighten the Motor Assembly Mounting Nuts③ in position so that there is no slack in the Dump Linkage Arm② while the dump bed is in the down position.

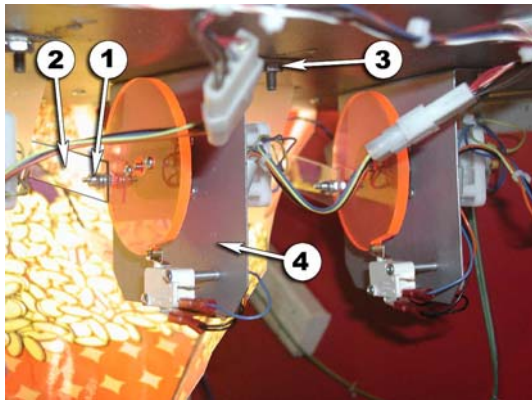

View looking in from front door



Worms-Eye View

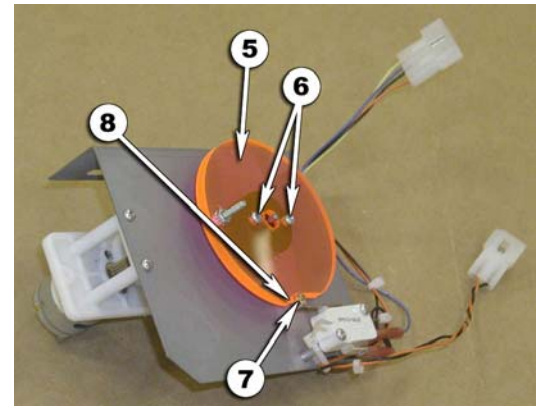

Motor Assembly out of game

Adjusting Coin Ramp Height

- Bend Ramp Bracket① so that the tip of the coin ramp is 3-3/4" above the Playfield②. Verify that the coin rolls off of the ramp high enough to enter the Bonus Targets③, and low enough to go under the Dump Lever Flags④.
 - Note: For the game to play properly, the coin must hit the Dump Lever Mast⑤ under the Dump Lever Flag④ in order to dump the truck. The coin should never hit the Dump Lever Flag④.

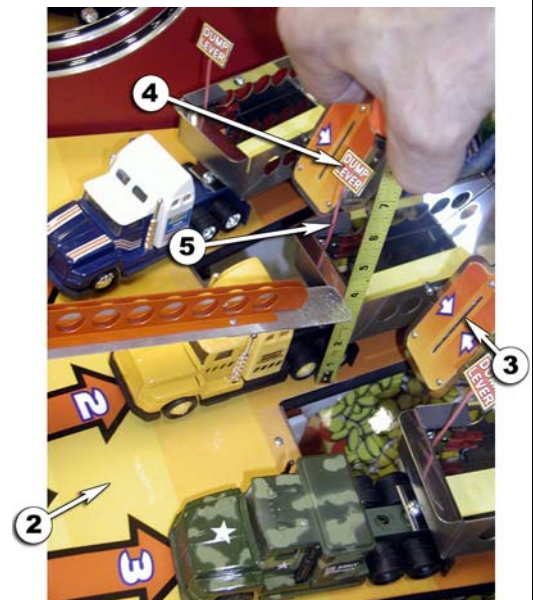
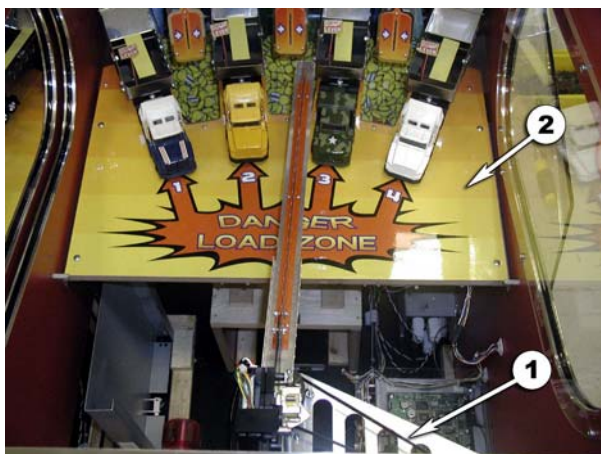

Changing a Bonus Display Board

1. Remove Instruction Plate① by removing (4) Instruction Plate Mount Screws②.
2. Disconnect harness.
3. Replace Bonus Display Board③
 - a. **Important:** Each display contains a Dipswitch④ and a terminating connector. If you are replacing a display it is important to set the Dipswitches to the correct positions and locate a Shunt⑤ across the Termination Connector⑥ on the proper Bonus Display Board③. Each display has a different setting. See Bonus Display Dipswitch Chart for correct settings. Only the 'A' display should contain the Shunt⑤.
4. Reinstall Instruction Plate and reconnect harness.

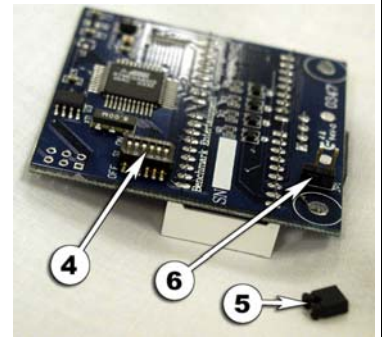
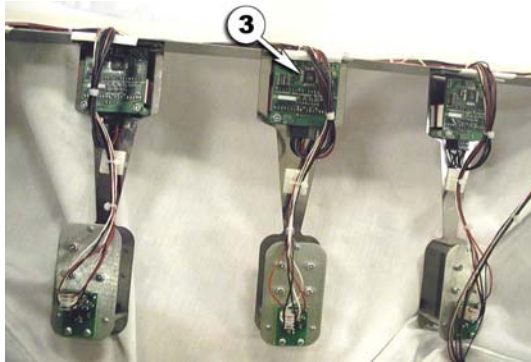

Rear View of Bonus Displays

Display #	Switch Number					
	1	2	3	4	5	6
A (shunt)	ON	ON	OFF	OFF	OFF	OFF
B	OFF	OFF	ON	OFF	OFF	OFF
C	ON	OFF	ON	OFF	OFF	OFF
D	OFF	OFF	OFF	OFF	OFF	OFF
E	ON	OFF	OFF	OFF	OFF	OFF
F	OFF	ON	OFF	OFF	OFF	OFF

Changing Bonus Opto Sensor

1. Remove (3) Opto Assembly Mount Screws①.
2. Detach harness at connector and remove (2) Opto Mount Screws②.
3. Replace Opto Sensor Board③, Reconnect Harness, and mount screws.

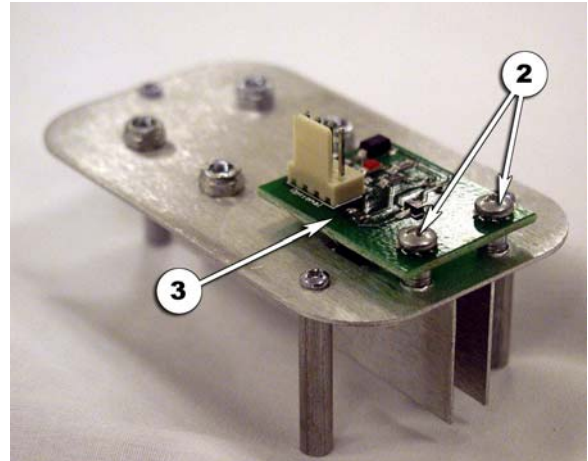

Opto Assembly removed from game

Programming Procedure for Big Rig

Press and hold Programming Button #1 ① located next to the main controller board. After two seconds Bonus Display D② will display a 1. At this time release Programming Button #1 ①. You are now in programming mode. Bonus Display 1 will display the programming option number and the value for that option will be shown on Bonus Display E③. Depressing Programming Button #1 ① will change to the next programming option, and depressing the Programming Button #2 ④ will change the value of the option.

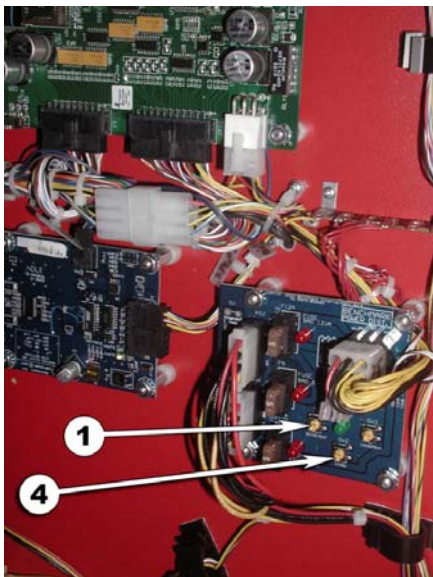

Programming Options

Option 1: Mercy Ticket

This option sets whether or not a ticket is paid for a miss.

0 = No Mercy Ticket

1 = One Mercy Ticket

Option 2: Coin Value Dumped Truck

This option sets the amount of tickets paid per coin when a truck is dumped. Values are from 1 ticket to 12 tickets per coin. Depressing the Black Programming Button will change the value from 1 to 12, then back to 5 again. Default is 5 tickets.

Option 3: Attraction Mode Volume

This option sets the volume for sound effects generated during Attraction Mode (no play activity). The range is from 0 (Off) to 64 (Max). When this option is entered the background music will begin to play. Depressing and holding the Black Programming Button will increase the volume all the way to the Max and then reverse and decrease the volume all the way to Off. Depress and hold the Black Programming Button until the desired volume is reached.

Option 4: Play Mode Volume

This option sets the volume for sound effects generated during Play Mode. The range is from 0 (Off) to 64 (Max). When this option is entered the background music will begin to play. Depressing and holding the Black Programming Button will increase the volume all the way to the Max and then reverse and decrease the volume all the way to off. Depress and hold the Black Programming Button until the desired volume is reached.

Option 5: Attraction Mode Frequency

This option sets the frequency with which Attraction Mode takes place. The range is from every 5 to 30 minutes. Depressing the Black Programming Button will increase the value from 5 to 30 minutes, and then return to 5 minutes.

Option 6: Maximum Bonus Target Value

This option sets the maximum bonus allowed. Settings are 300, 500, 700, 900, and 1000 tickets. Depressing the Black Programming Button will increase the value to 1000, then return to 300.

Option 7: Bonus Target Increment Frequency

The Max Bonus value increases (in increments determined by Option 8) until it reaches the Maximum Bonus set in Programming Option 6. It then returns to a value of 200 tickets and starts incrementing again. Increasing the Bonus ticket value can be programmed with this option to occur every 1, 2, 3, 4, or 5 plays. Depressing the Black Programming Button will increase the value from 1 to 5 plays, then return to 1.

Option 8: Bonus Target Increment Value

This option sets the amount that the Bonus value increases each time that it progresses. Depressing the Black Programming Button will increase the value in increments of 10 from 20 to 100, then return to a value of 20.

Option 9: Empty Truck Dumped Value

This option sets the number of tickets paid if an empty truck is dumped. The values are 50, 100, and 150 tickets. Depressing the Black Programming Button will increase the value to 150, then return to 50.

Option 10: Coin Value in the Truck

This option sets the number of tickets paid if a coin lands in a truck. The values are from 1 to 12 tickets. Depressing the Black Programming Button will increase the value to 12, then return to 1.

Option 11: Reset Seed Values

This option resets the amount of coins present in the trucks. Depressing the Black Programming Button will reset all of the values to 15 coins per truck. When the Black Programming Button is depressed, the values will be reset and Programming Option 12 will be displayed. At this time release the Black Programming Button.

Option 12: Clear Tickets Owed.

This option resets the log of tickets that have been won but not dispensed. Depressing the Black Programming Button will set the log to zero and Programming Option 13 will be displayed. At this time release the Black Programming Button.

Option 13: Free Play

This option sets Free Play Mode. In this mode, the game action is normal, however no tickets are dispensed. If this mode is enabled, it will stay active until the power is reset. Note: Every time the Programming Mode is entered, this option will have to again be set to 1 if Free Play is desired.

0 = Free Play Mode Off

1 = Free Play Mode On

Option 14:

When Option 14 is displayed, depressing the Red Programming Button will return to Option 1 of the Programming Mode. Depressing the Black Programming Button will end Programming Mode and return to Normal Mode.

DEFAULT VALUES

The following are the recommended default values:

1. Mercy Ticket = 0, No Mercy Ticket
2. Coin Value Dumped Truck = 5 Tickets per Coin
3. Attraction Mode Volume = 42
4. Play Mode Volume = 42
5. Attraction Mode Frequency = every 5 minutes
6. Maximum Bonus Target Value = 500
7. Bonus Target Increment Frequency = every play
8. Bonus Target Increment Value = 50
9. Empty Truck Dumped Value = 100
10. Coin Value in the Truck = 10

right side cabinet wire harness

c- is symbol for connector

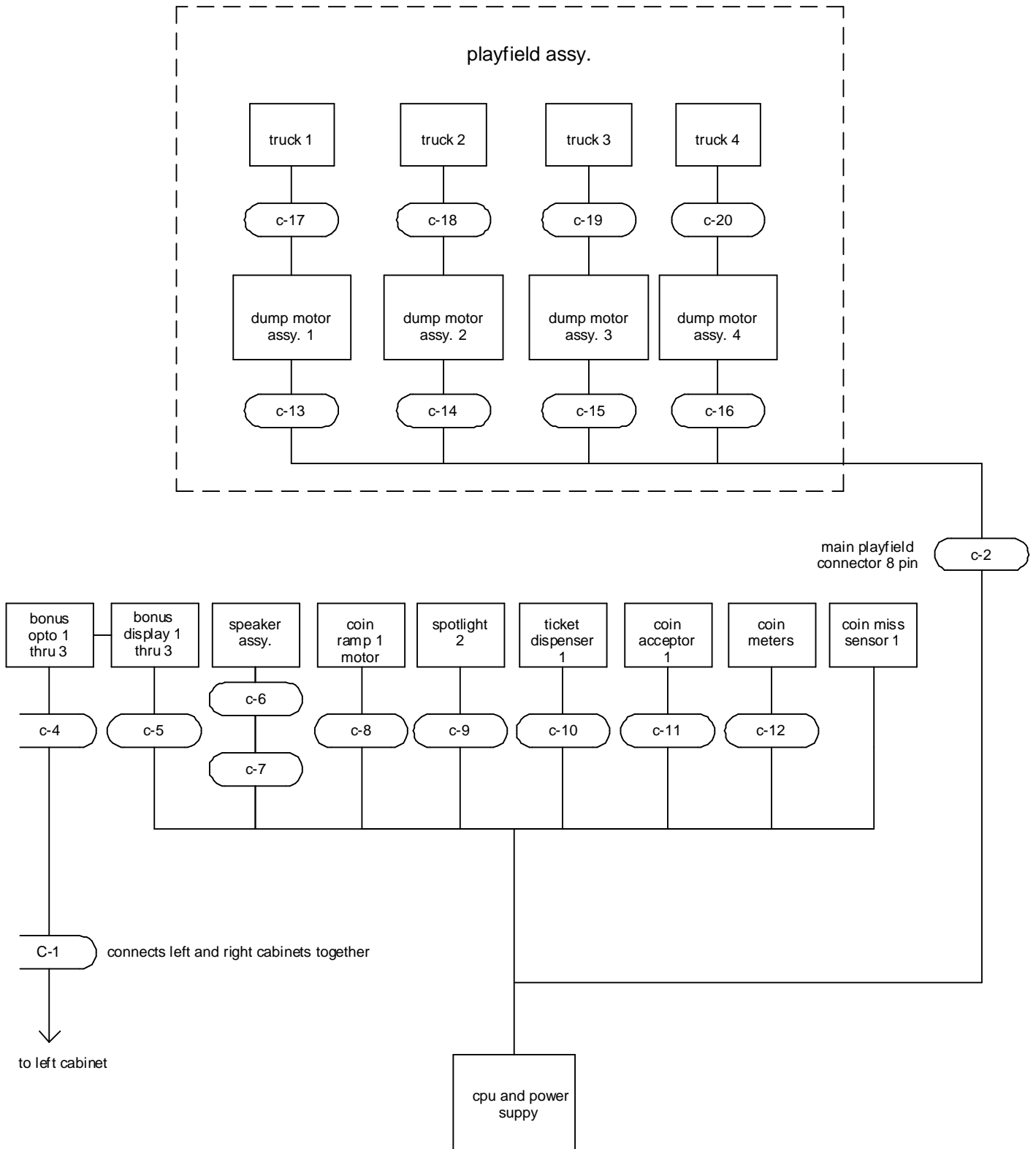

right side playfield dump motors

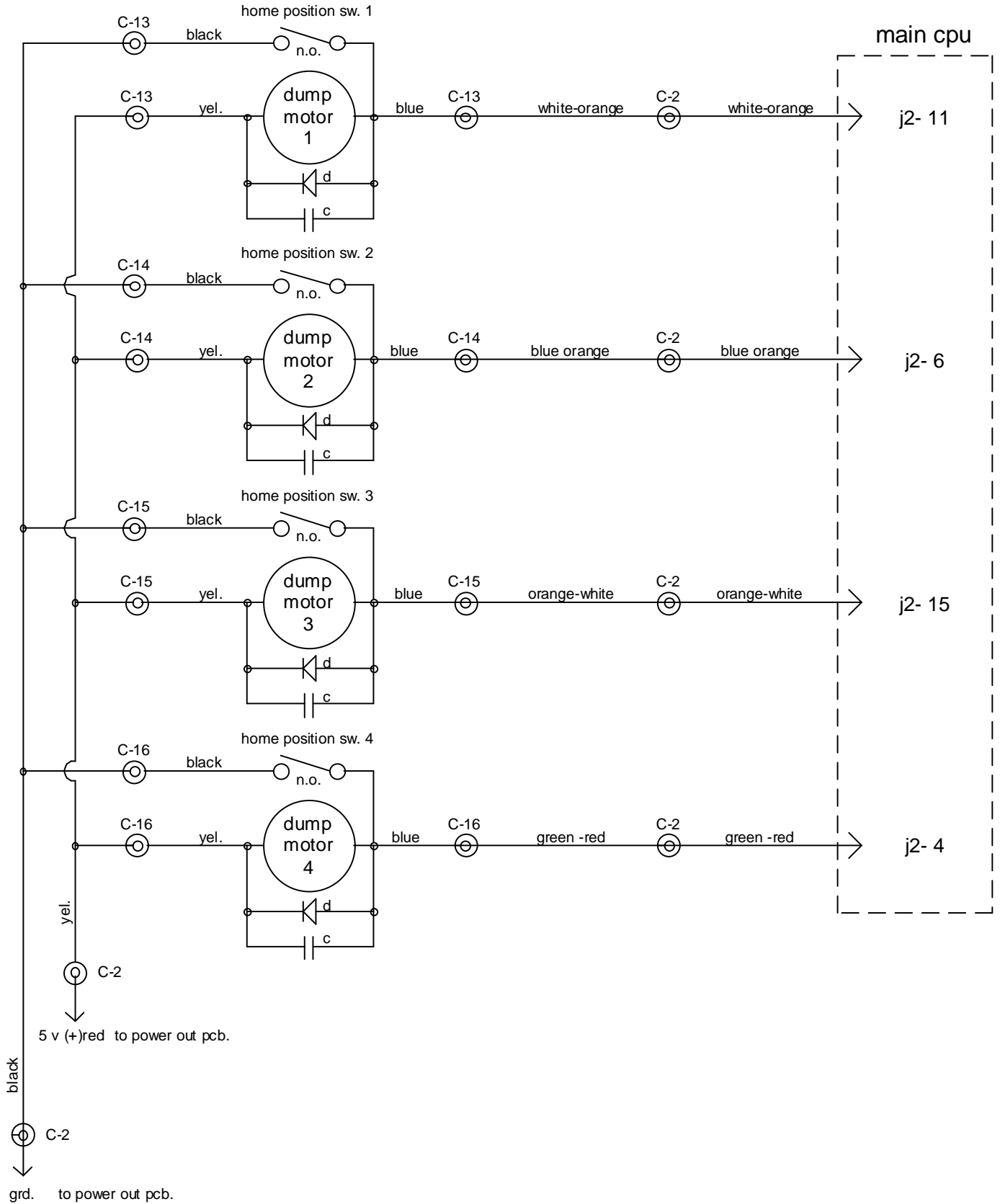

right side cabinet

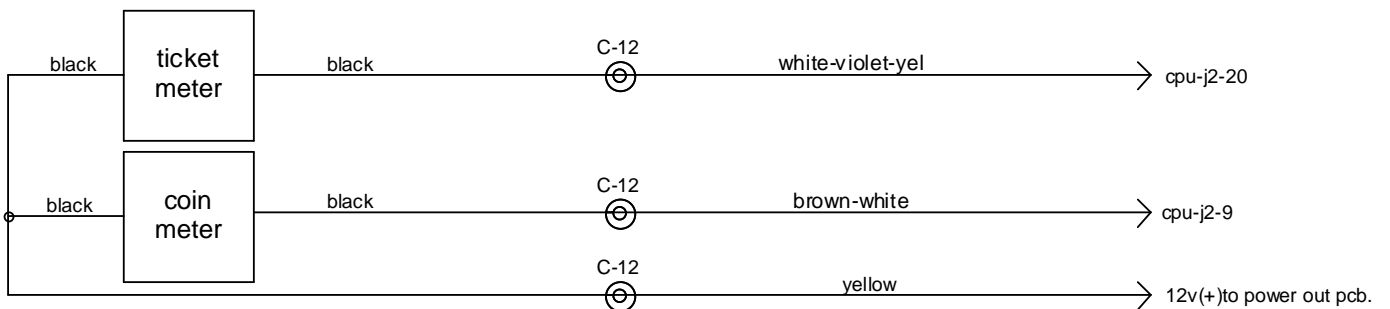
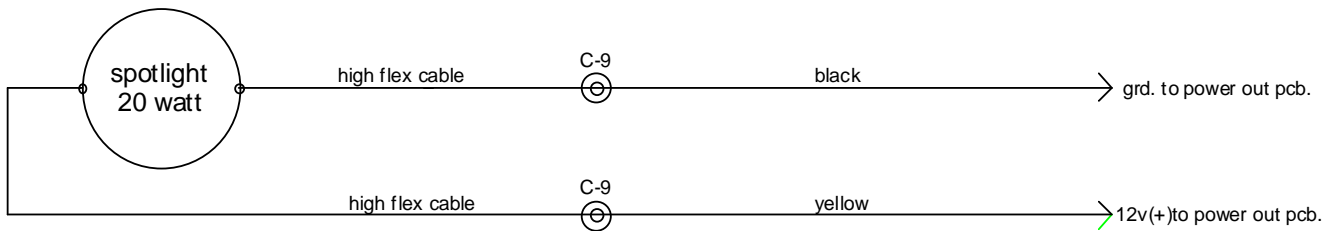
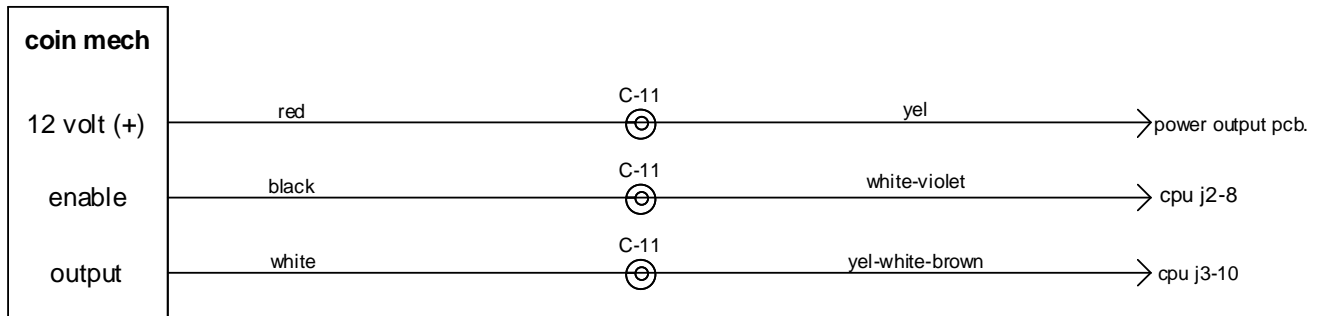
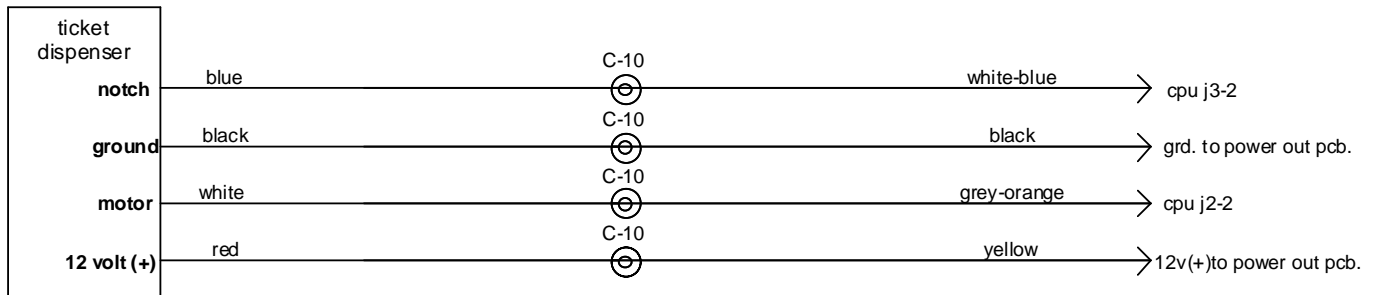
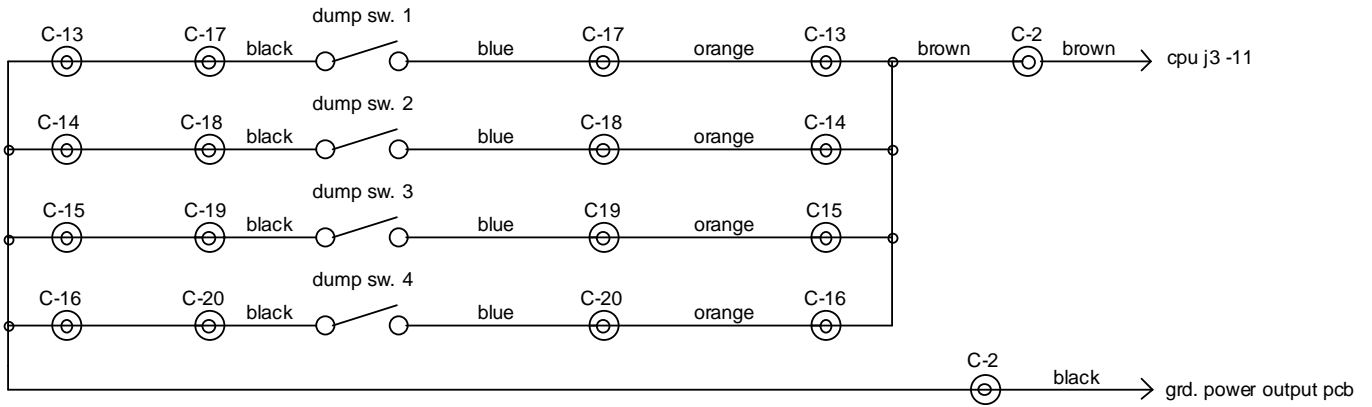

right side cabinet

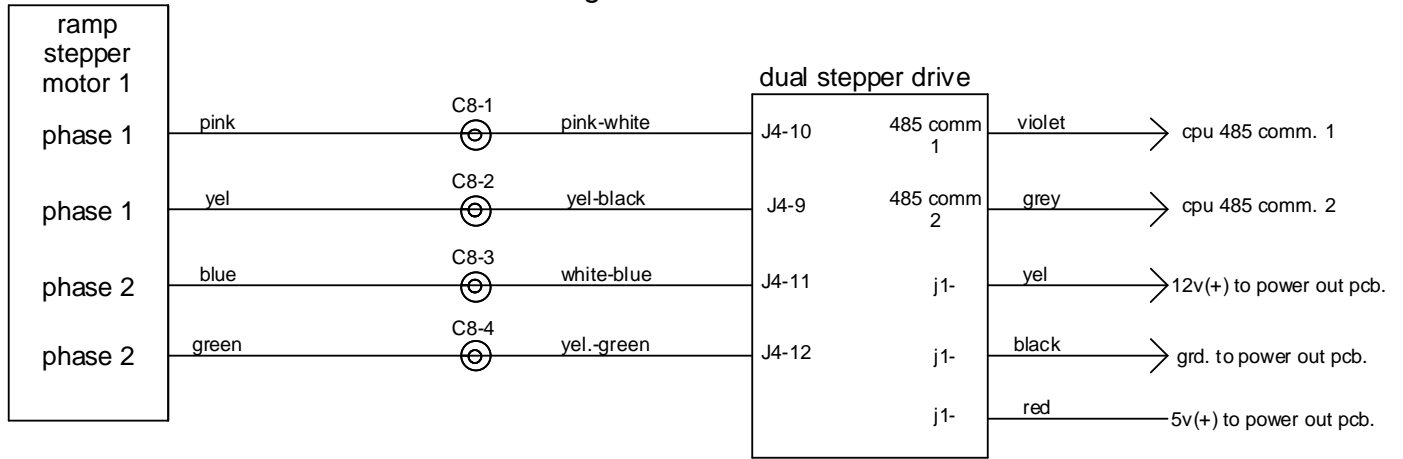

bonus target assy.

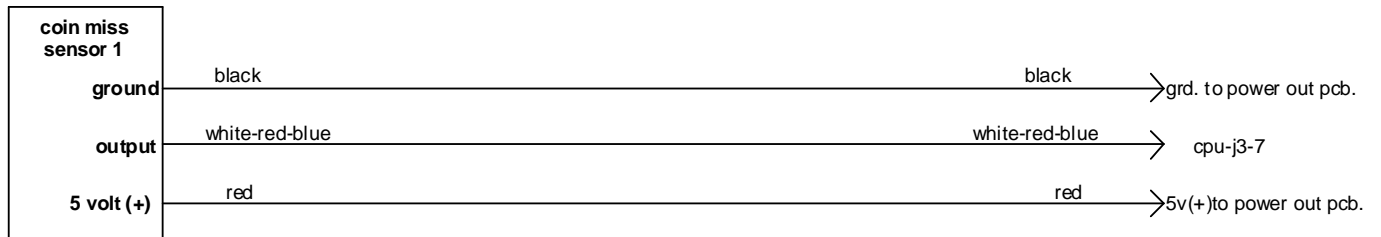
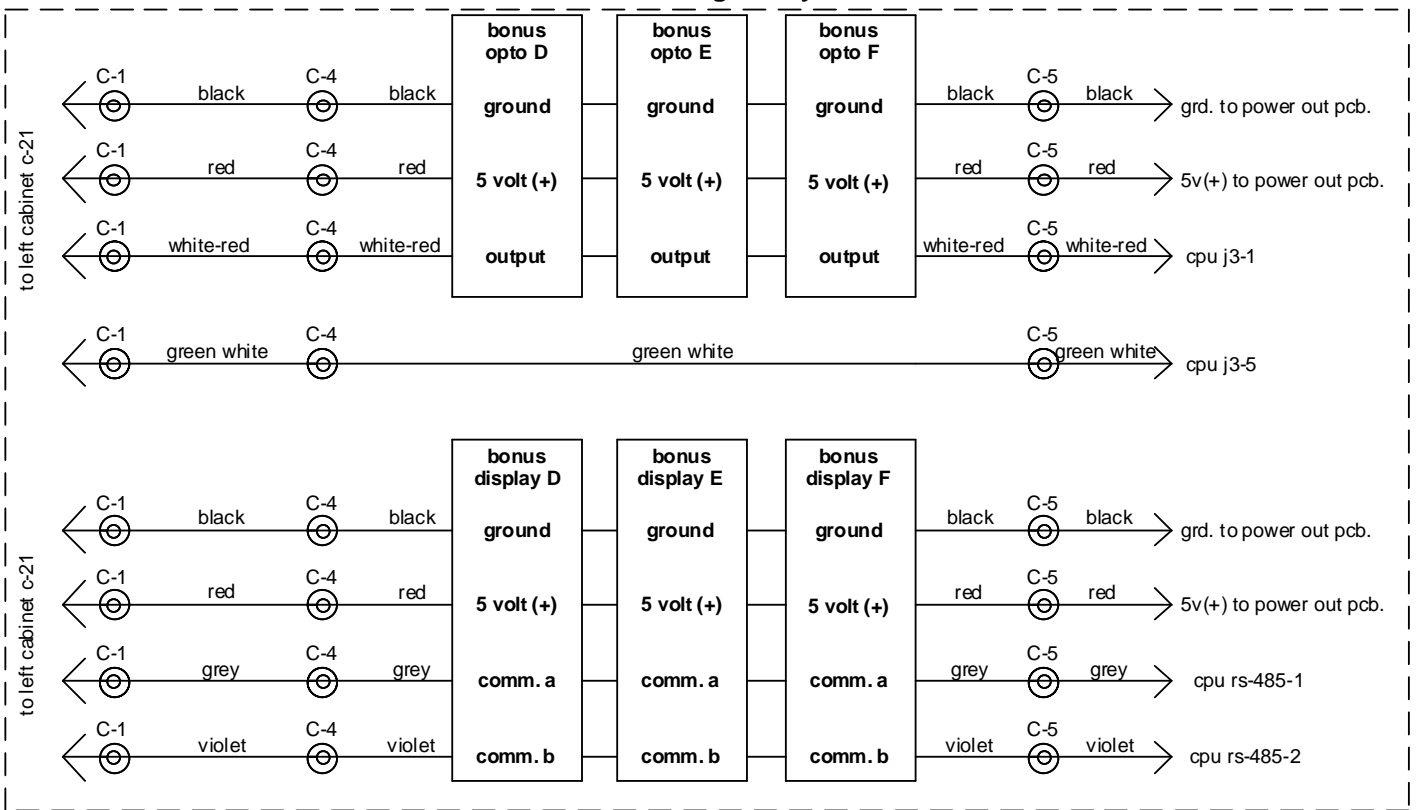

RIGHT SIDE CABINET

speaker-header assy.

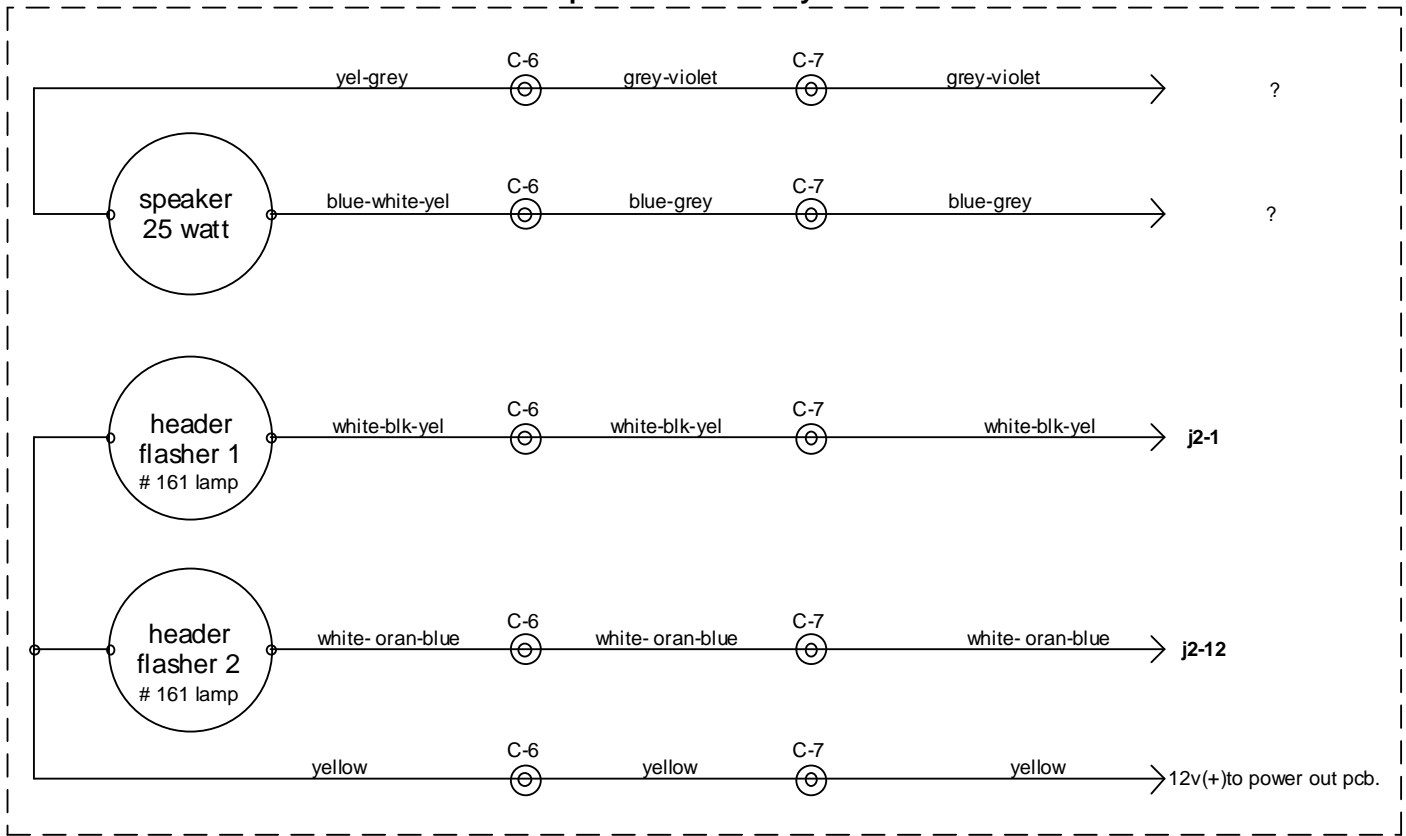

right side cabinet wire harness

c- is smybol for connector

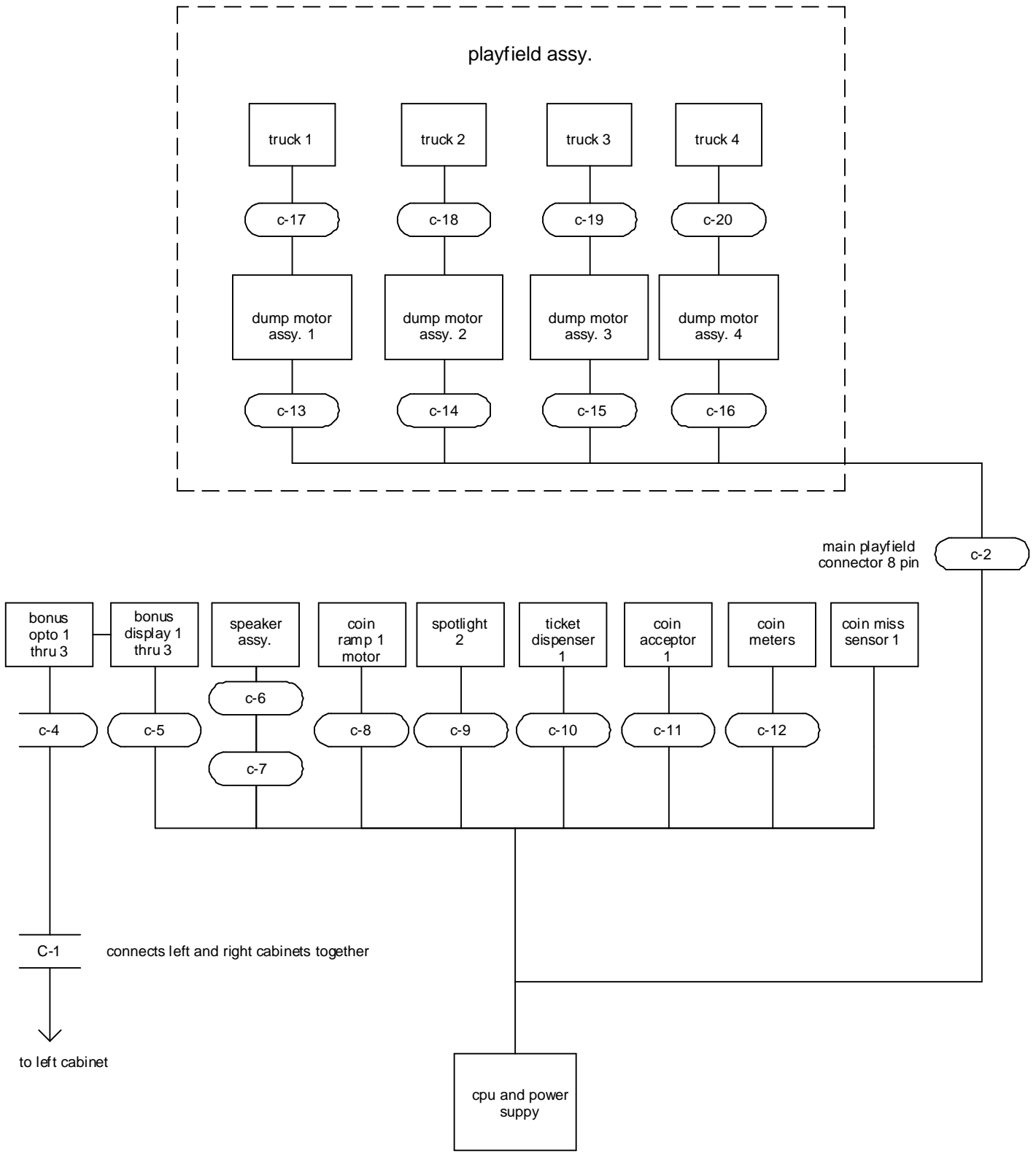

left side playfield dump motors

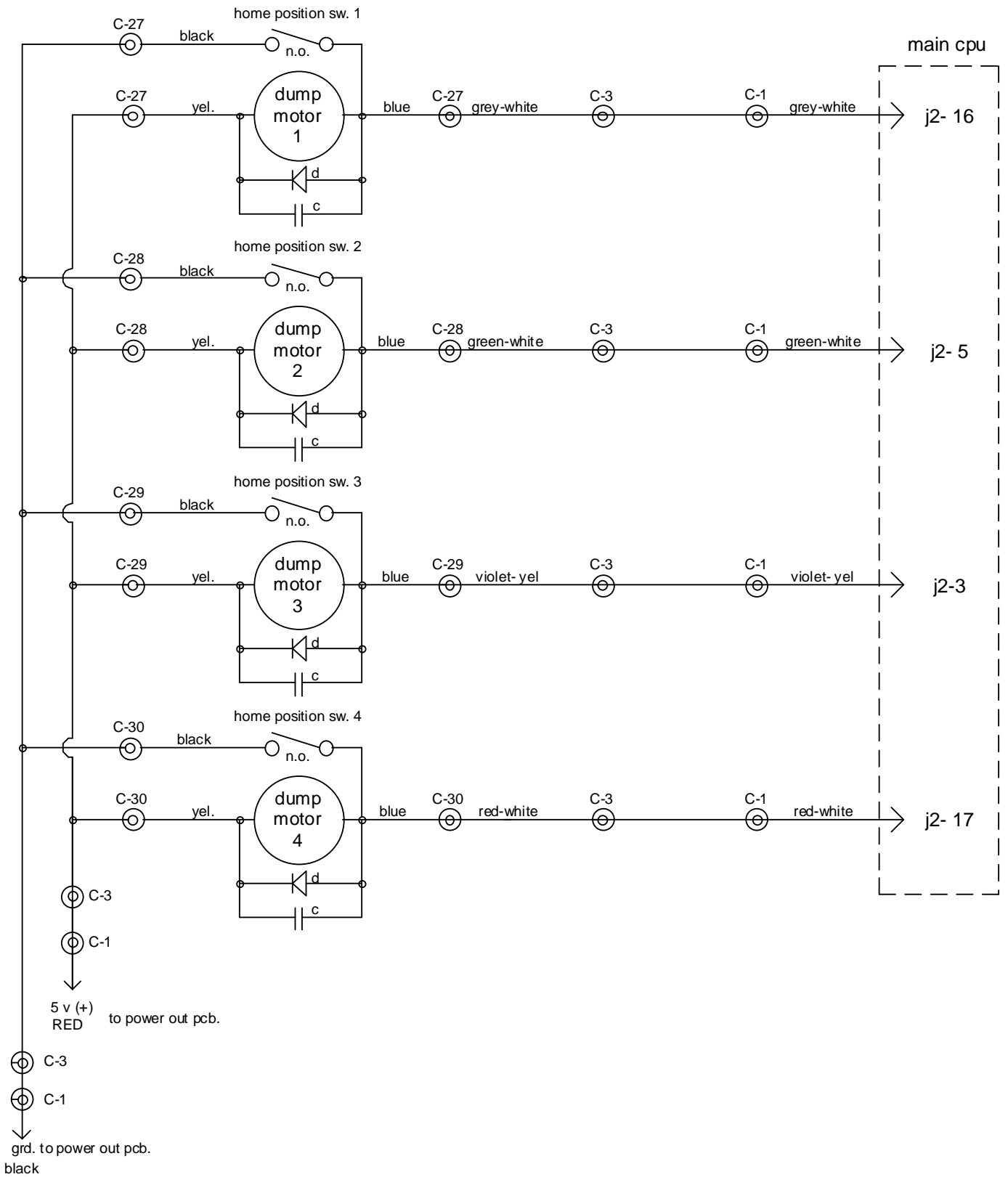

left side cabinet

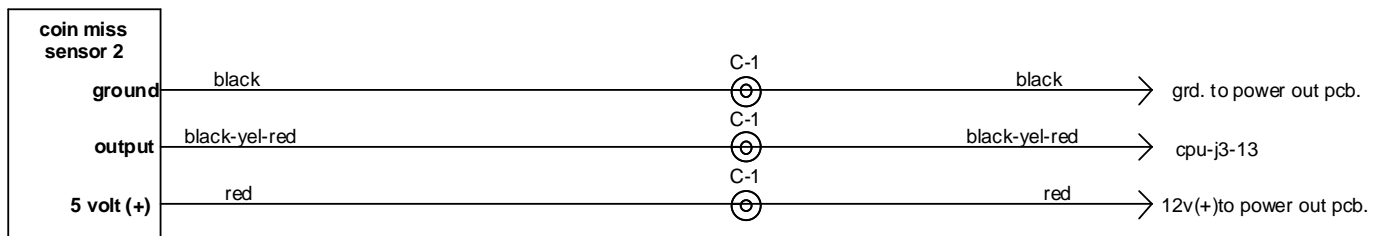
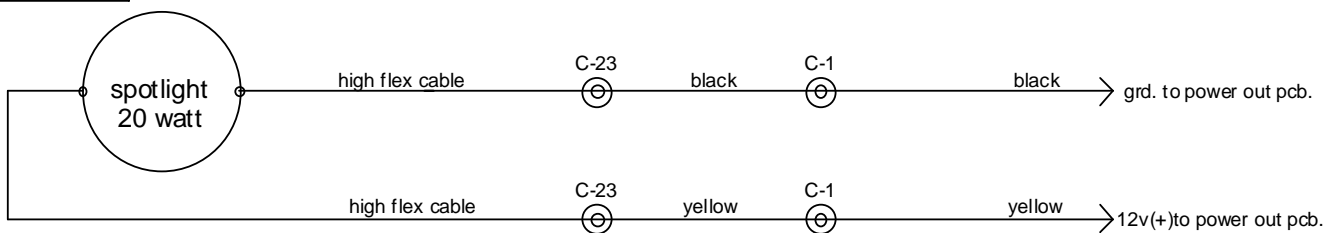
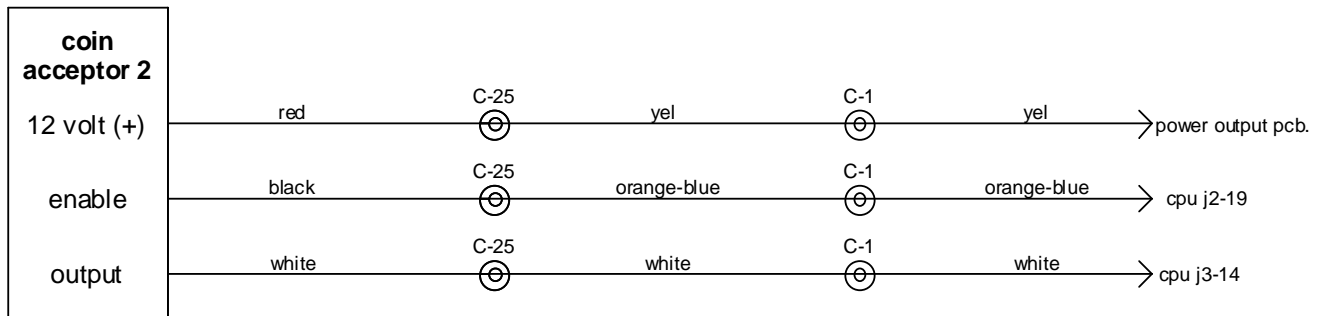
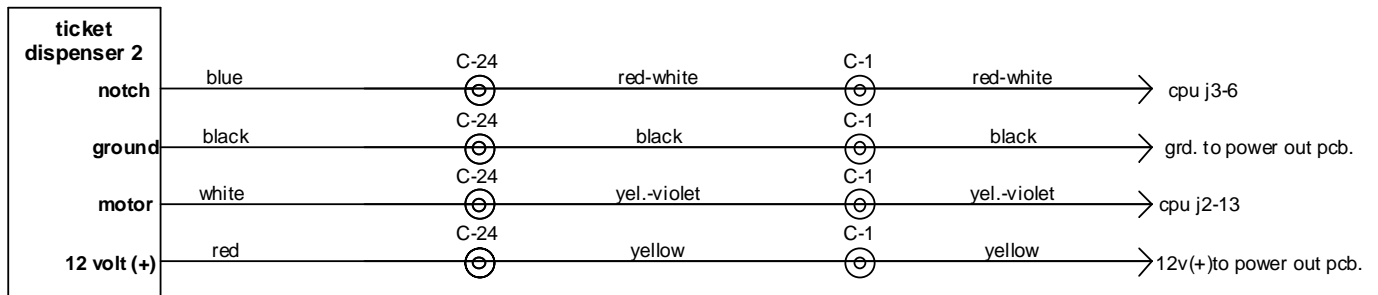
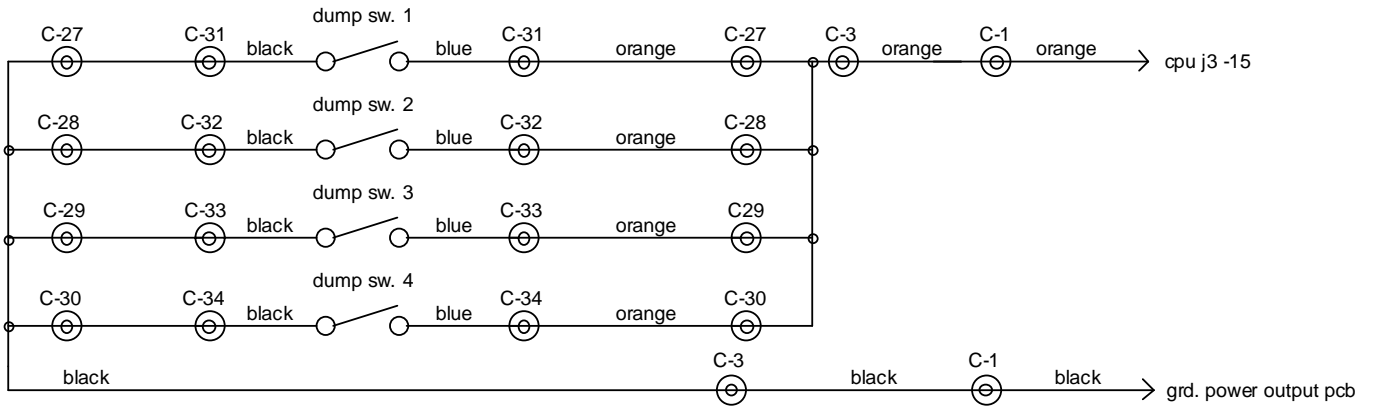

note C-1 connects right side to left side

left side cabinet

bonus target assy. left cabinet

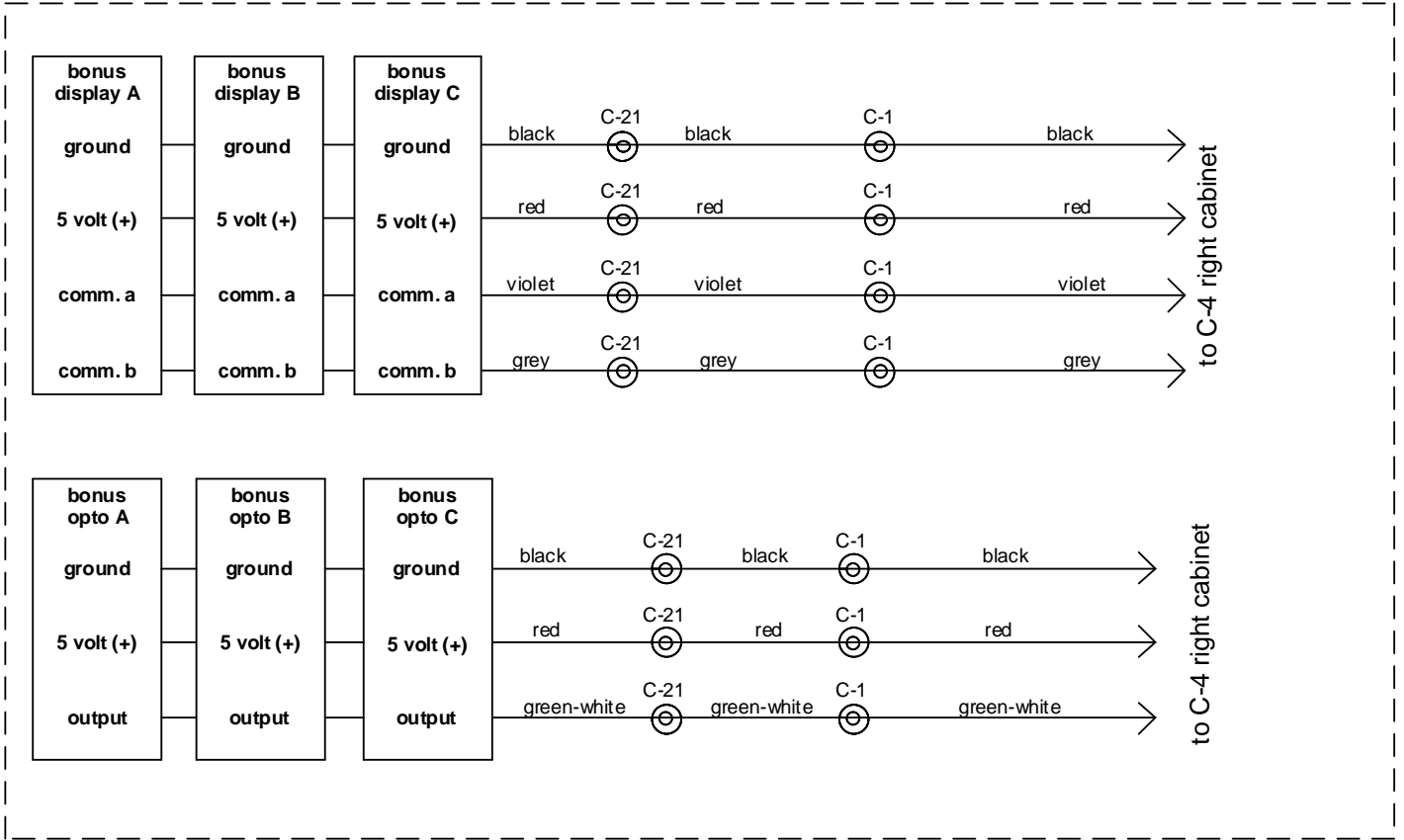

left side cabinet

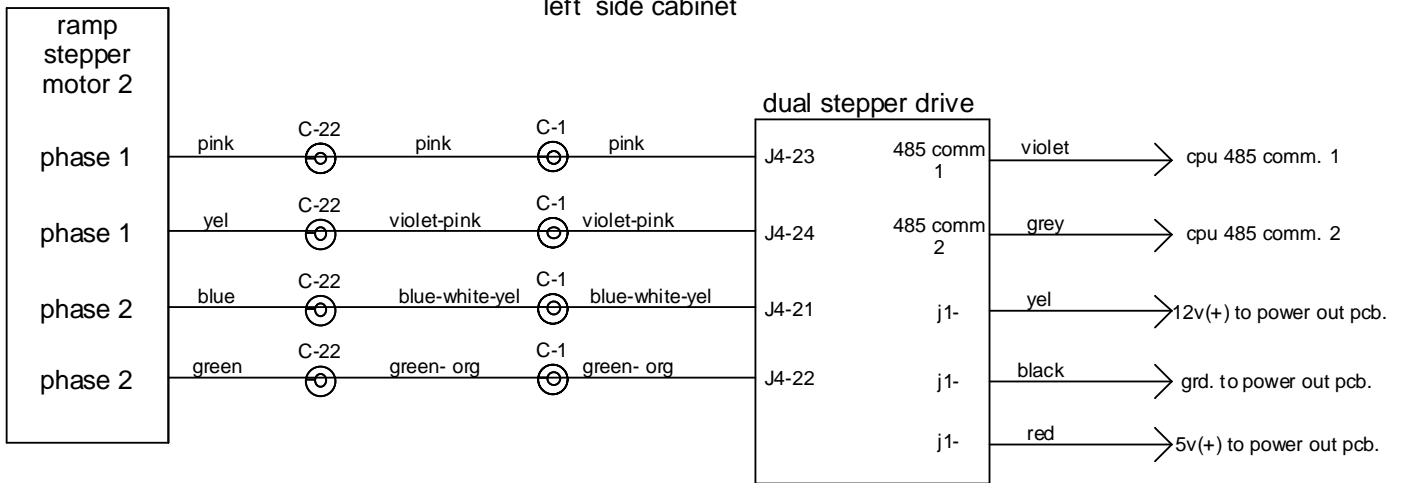

C-1 IS CONNECTOR FOR LEFT AND RIGHT CABINET