

# MC SERIES Bill Acceptors



## INSTALLATION AND SERVICE MANUAL



# TABLE OF CONTENTS

---

## SECTION 1: GENERAL INFORMATION

Introduction.....	3
Product Features.....	3
For your records.....	3
Unpacking.....	3
Installation.....	3
Diagnostic LED.....	3

## SECTION 2: MAINTENANCE

Cleaning Material.....	4
Cleaning.....	4

## SECTION 3: NAMING CONVENTION

MC Series Naming.....	5
-----------------------	---

## SECTION 4: COMPONENT EXPLANATION

Input Power Requirements .....	6
Bill Acceptance.....	6
Bezel Types.....	6
Component Definition.....	7
Dip Switch Configurations.....	8
MC2600/MC2800 Slimline Bezel.....	9
MC2600/MC2800 Standard Bezel.....	10
MC7200 Slimline Bezel.....	11
MC7200 Standard Bezel.....	12
18 Pin Mating Connector.....	13
6 Pin Mating Connector.....	13
30 Pin Mating Connector.....	13
16 Pin Mating Connector.....	13

## SECTION 5: DISASSEMBLY

Tools Needed.....	14
Removing the Cashbox Assembly.....	14
Removing Motors from Stacking Assembly.....	15
Removing the Bezel.....	15
Removing the Front Cover.....	16
Removing Harness from microboard.....	17
Removing Bottom Sensor Assembly.....	17
Removing Microboard.....	18
Removing Drive & Stacker Chassis Assembly..	21
Removing Top Sensor Assembly.....	22
Removing Stacker Plate.....	22
Removing Belts.....	24
Removing Motors.....	27
Disassembling Bottom Sensor Assembly.....	28
Removing Encode Wheel.....	26
Removing Side Sensor.....	29
Removing Top Sensor Board.....	31

## SECTION 6: PARTS LIST

Overview.....	32
MC Series Drive Chassis Assembly.....	34
Drive & Stacker Chassis.....	35

## SECTION 7: PC BOARD INTERFACE CONNECTIONS

PC Board & Part Numbes.....	36
MC Series Cashboxes.....	36
110 VAC Pulsed Interface (30 Pin).....	37
110 VAC Vend Serial Interface (30 Pin).....	37
24 VAC Pulsed Interface (30 Pin).....	38
24 DC MDB Interface (30 Pin).....	38
12V MDB Interface & MDB	
Wake/Sleep(16 Pin).....	39
12V Ardac2/ITC Serial Interface (16 Pin).....	39
12V Pulse Interface (16 Pin).....	40

## SECTION 8: HARNESS INTERFACES

Harness # 027202.....	41
Harnes # 027281.....	41
Harness # 408730.....	42
Harness # 408721.....	42
Harness # 408720.....	43
Harness # 408731.....	43
Accessory Kit # 408903.....	44
Harness # 408732.....	44

## SECTION 1: GENERAL INFORMATION

### Introduction

This manual contains information on installing, operating, and maintaining the MC Series bill acceptors. This manual is intended for owners, route operators and shop-level technicians as a primary source of information. Taking time to read this manual and becoming familiar with this information will help you obtain the best performance from your MC Series bill acceptor.

### Product Features

- Bill widths accepted: MC2600 and MC2800 (66mm), MC7200 (72mm)
- Operating Voltages: 110VAC, 24VAC, 24VDC, 12VDC
- Communication Interface: MDB, Pulse, Vend Serial, ccTalk, ICT serial and Ardac 2 serial over RS232.
- Four-Way Acceptance
- Mounting: Upstack or Downstack
- Lighted Bezel (on standard mask only)
- Coupon capable
- Superior Stringing Protection

### Operating Temperature Range:

0°F - 150°F

### For Your Records

A label indicating the model number and serial number is affixed to the lower left hand side (when facing the bill inlet). of the bill acceptor. Refer to the model and serial number whenever you call upon Coinco/Money Controls for information or service.

### Unpacking

After unpacking the unit, inspect for any possible shipping damage. If damaged, notify the shipping company immediately. Keep the carton and packing material to reuse if you need to transport or ship the bill acceptor in the future. Labels indicating the model and serial number are on the side of the bill acceptor.

Refer to these numbers when calling upon your Coinco Service Center representative for information or service.

### Installation

**NOTE: The Metal mounting plate must be connected to earth ground.**

1. Remove power from host machine.
2. Set bill acceptor dip switches. (see Page 4).
3. Install the bill acceptor into the host machine using the mounting studs and hardware in the machine.
4. Install / Connect the proper interface harness to the host machine.
5. Apply power to the machine, verify that the Green Flashing Arrows on the front of the bill acceptor are ON and blinking. This condition indicates that the bill acceptor is ready to accept bills.
  - If the Lights are off, check wiring harness connections and make sure power is applied.
  - Also check the rear diagnostic LED, the status codes are listed on the cashbox and in Figure 2 below.
6. Check Operation, once the Green Arrows are flashing, insert bills to verify proper acceptance and credit.

Diagnostic LED	
# of LED Flashes	Status
Normal Pulse Rate 1 pulse per second	Ready
Fast Pulse Rate 3 pulses per second	Check Stacker/Cashbox
Not Lit	Check Power
Steady ON	Replace Acceptor
2 Flashes	Bill Inhibited
3 Flashes	Disabled by Host
4 Flashes	Clear Bill Path
5 Flashes	Clean Bill path

## SECTION 2: MAINTENANCE

### Maintenance

#### Recommended Cleaning Material:

A mild solution of detergent can be used for cleaning the belts, bill path and sensor lenses, as well as for general cleaning of the acceptor. Beverages or other water-soluble liquids which have been spilled on or into the acceptor can usually be removed with warm soapy water. External surfaces can be cleaned with a damp cloth.

Note: Petroleum-based cleaners and freon-based propellants can damage plastic and some electronic components. Scouring pads and stiff brushes may harm the circuit boards and can mar the plastic. These items should never be used when cleaning the bill acceptor.

#### Cleaning the Optical Sensor Lenses and Gray Scales

**Warning:** *Remove power from the bill acceptor before opening the bill path.*

Remove the cash box and bottom sensor housing from the acceptor. To clean the optical sensor lenses and gray scales use a "Lint Free" cloth with a mild detergent. Repeat the cleaning process as needed until all the sensor surfaces are free of contaminants. Remember to clean both sensor lenses.

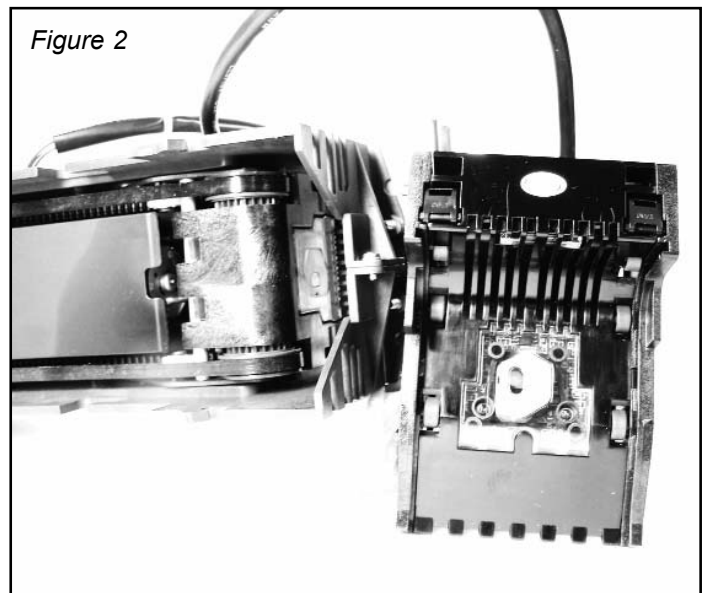

# SECTION 3: NAMING CONVENTION

## MC Series Model Naming Convention (Coinco Part #MC925926 Rev. 7)

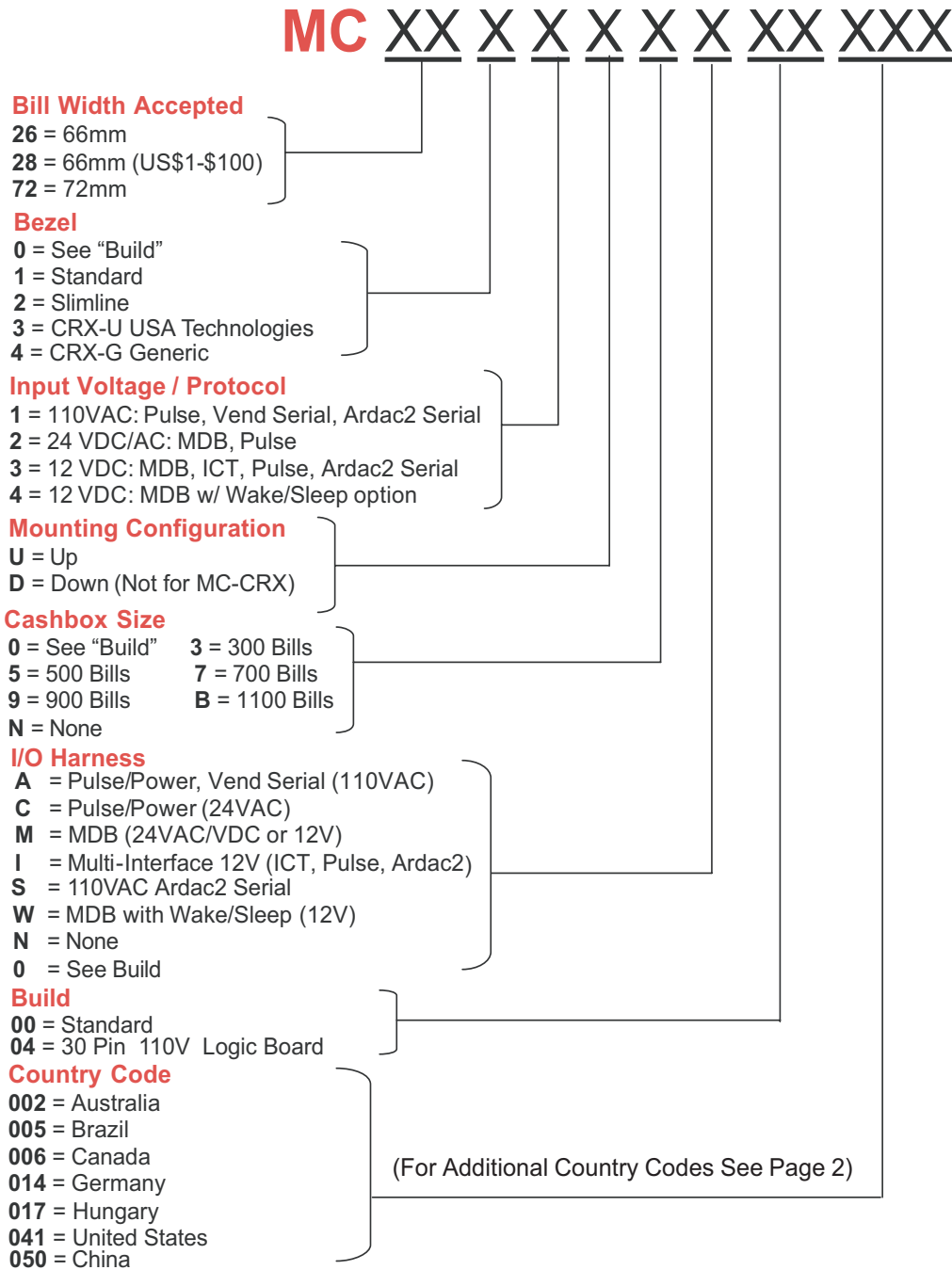

## Retrofit Card Reader Only

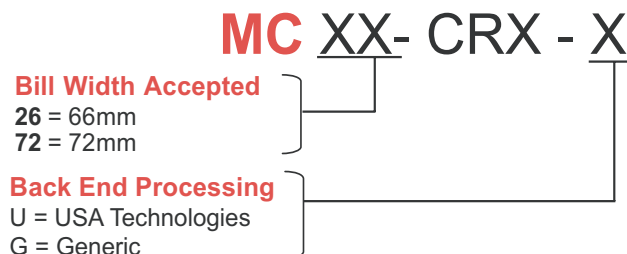

## SECTION 4: COMPONENT EXPLANATION

---

### Input Power Requirements

MCxxx1	120 VAC	90-135VAC @1.0A
MCxxx2	24VAC	20-32VAC @1.5A
MCxxx2	24VDC (MDB)	20-45VDC @1.5A
MCxxx3/MCxxx4	12VDC	10-14VDC @4A

### Bill Acceptance:

US MC2600 66mm	\$1	\$5	\$10	\$20		
US MC2800 66mm	\$1	\$5	\$10	\$20	\$50	\$100
CANADA MC7200 72mm	\$5	\$10	\$20	\$50	\$100	
EURO	€5	€10	€20			

### Bezel Types

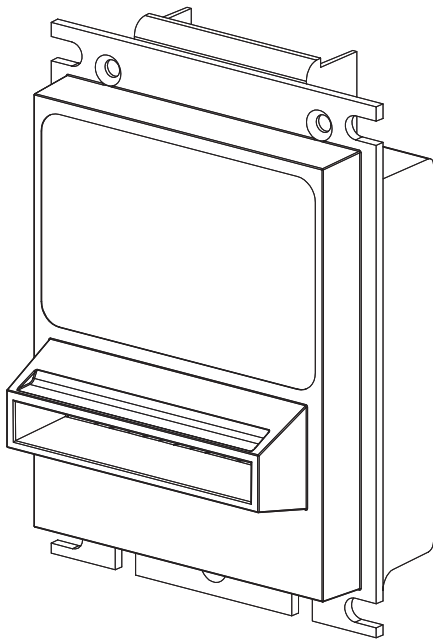

**Slimline Bezel**

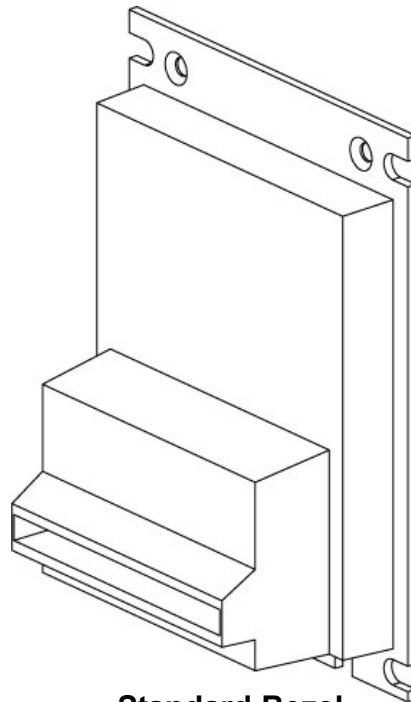

**Standard Bezel**

*NOTE: Both bezels available in downstack configuration.*

## SECTION 4: COMPONENT EXPLANATION

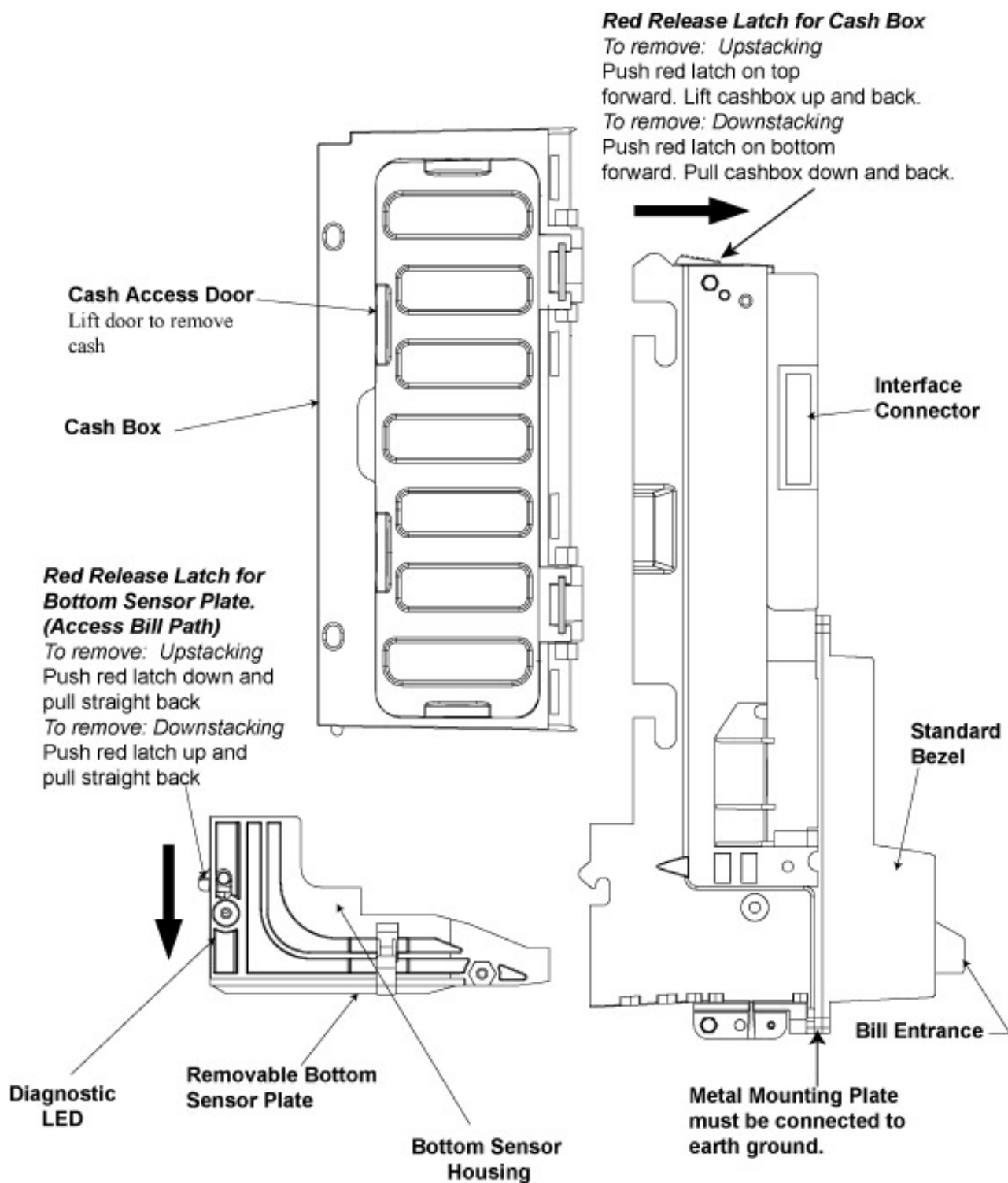

## SECTION 4: COMPONENT EXPLANATION

	US Dip Switch ON/OFF (MC2600)	US Dip Switch ON/OFF (MC2800)	Canada Dip Switch ON/OFF (MC7200)	Euro Dip Switch ON/OFF
Switch 1	\$1 enable/disable	\$10 enable/disable	\$10 enable/disable	€5 enable/disable
Switch 2	\$5 enable/disable	\$20 enable/disable	\$20 enable/disable	€10 enable/disable
Switch 3	\$10 enable/disable	\$50 enable/disable	\$50 enable/disable	€20 enable/disable
Switch 4	\$20 enable/disable	\$100 enable/disable	\$100 enable/disable	RESERVED
Switch 5	4 Pulse/1 Pulse per \$	4 Pulse/1 Pulse per \$	4 Pulse/ Pulse per \$	RESERVED
Switch 6	Always/Harness enabled	Always/Harness enabled	Always/Harness enabled	RESERVED
Switch 7	Short Pulse/Long Pulse	Short Pulse/Long Pulse	Short Pulse/Long Pulse	RESERVED
Switch 8	Coupon enable/disable	Coupon enable/disable	Coupon enable/disable	RESERVED

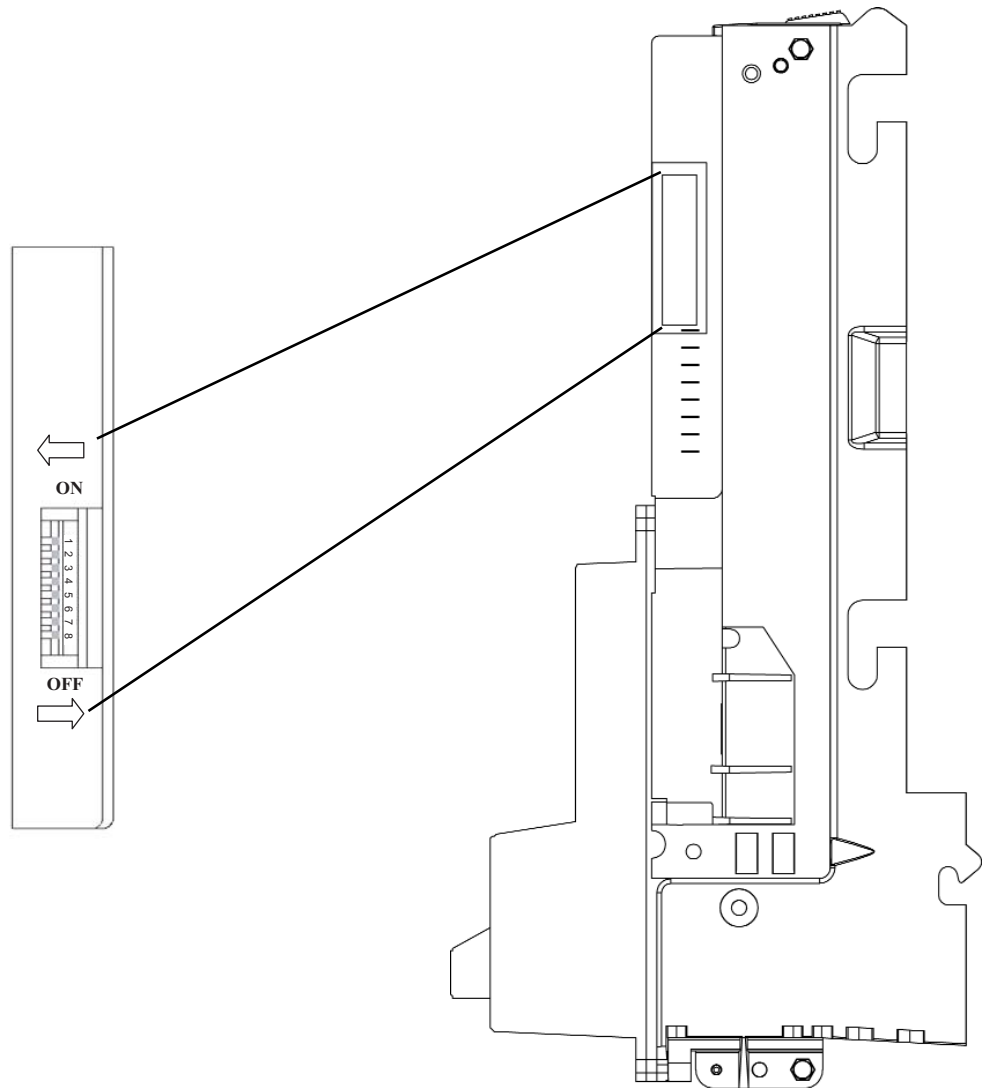



## SECTION 4: COMPONENT EXPLANATION

### MC2600/MC2800 with Slimline Bezel

1. All dimensions shown are for reference purposes and are subject to manufacturing and assembly tolerances.
2. All dimensions shown are in inches/millimeters

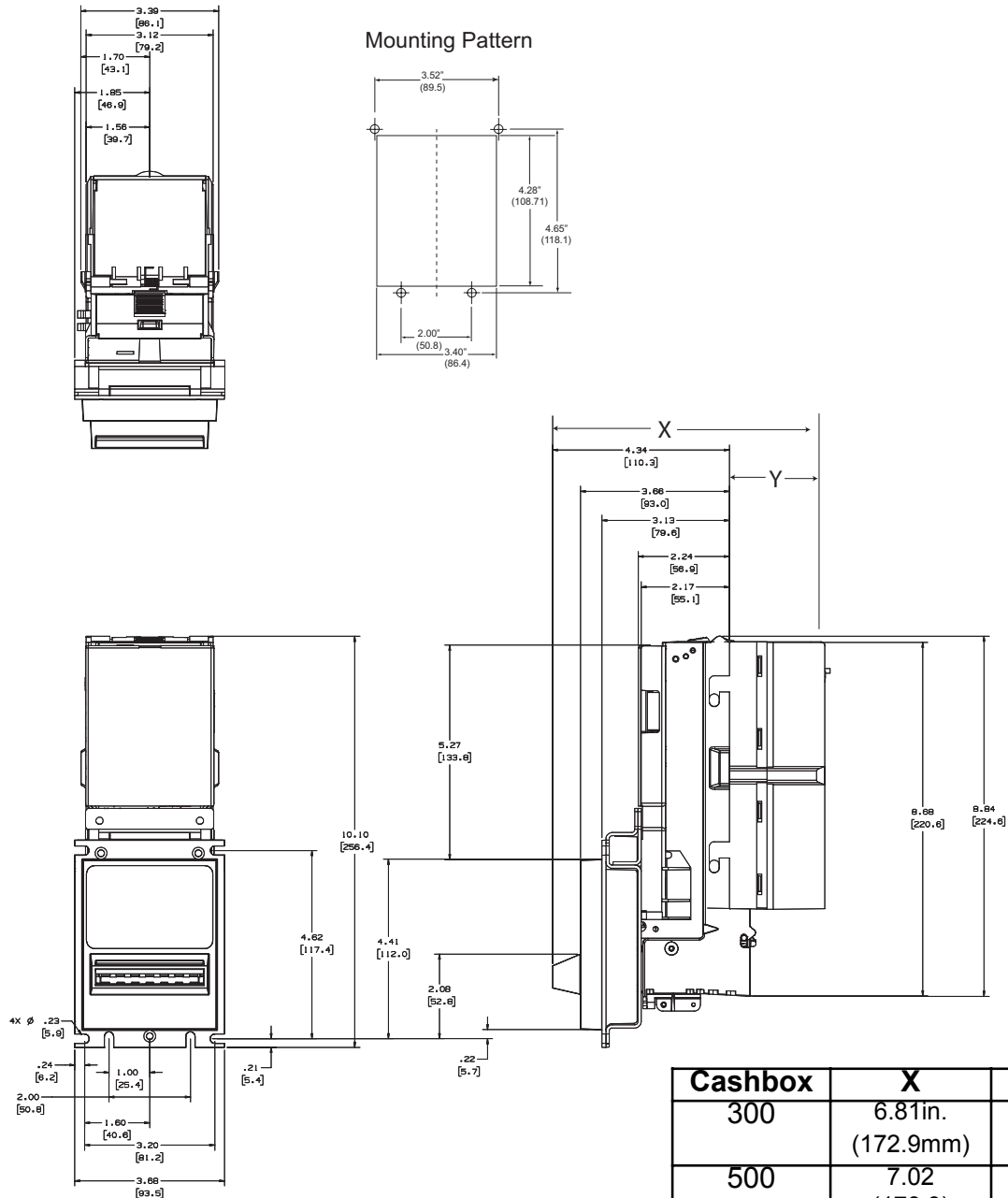

Cashbox	X	Y
300	6.81in. (172.9mm)	2.47in. (62.7mm)
500	7.02 (178.3)	2.67 (67.8)
700	8.06 (204.7)	3.72 (94.5)
900	9.10 (231.1)	4.76 (120.9)
1100	10.14 (257.6)	5.80 (147.3)

## SECTION 4: COMPONENT EXPLANATION

### MC2600/MC2800 w/ Standard Bezel

1. All dimensions shown are for reference purposes and are subject to manufacturing and assembly tolerances.
2. All dimensions shown are in inches/millimeters

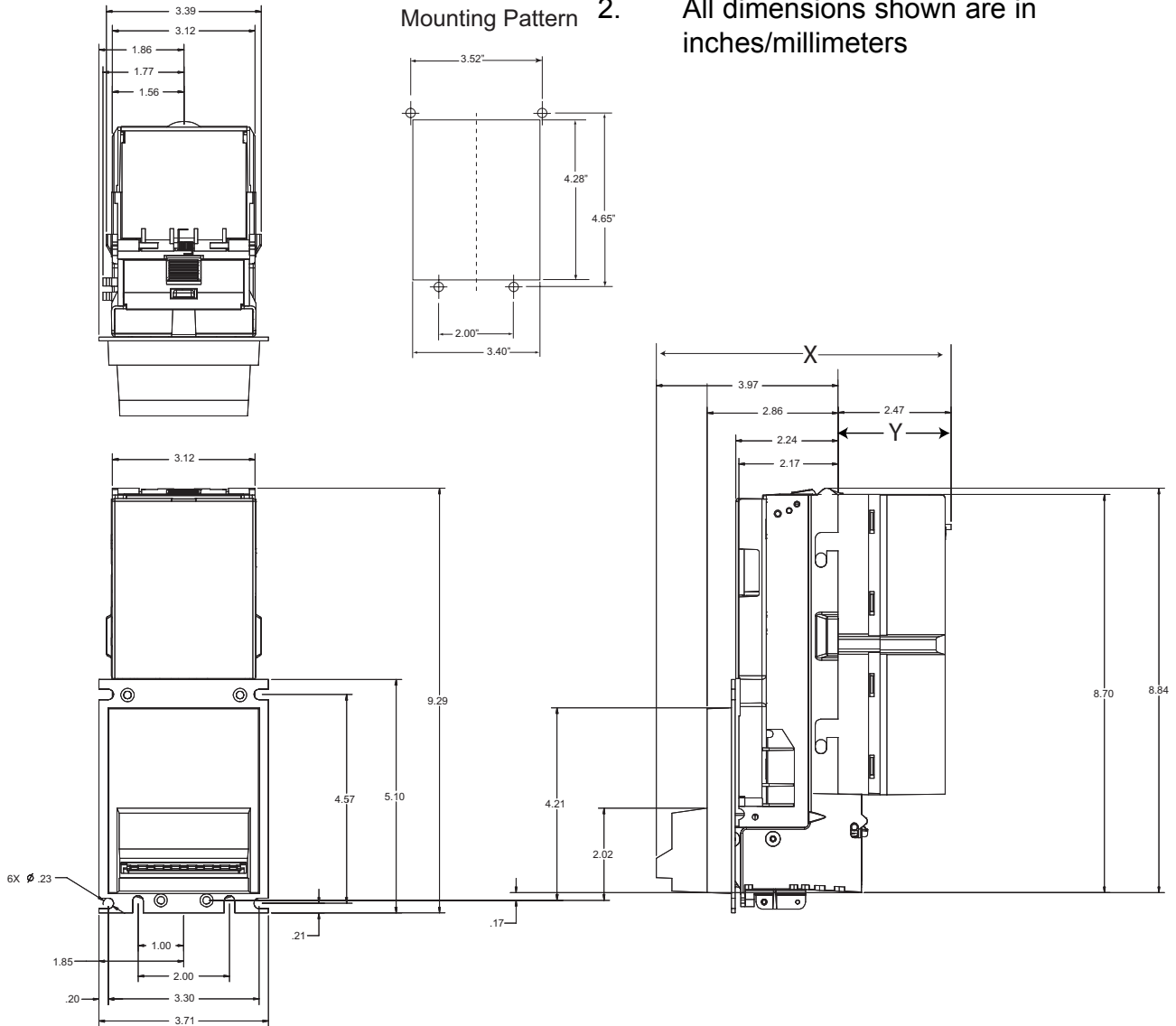

Cashbox	X	Y
300	5.33in. (135.4mm)	2.47in. (62.7mm)
500	5.54 (140.1)	2.68 (72.6)
700	6.58 (167.1)	3.72 (94.5)
900	7.62 (193.5)	4.76 (120.9)
1100	8.66 (220)	5.80 (147.3)

## SECTION 4: COMPONENT EXPLANATION

### MC7200 with Slimline Bezel

1. All dims shown are for reference purposes and are subject to manufacturing and assembly tolerances.
2. All dimensions shown are in inches/millimeters

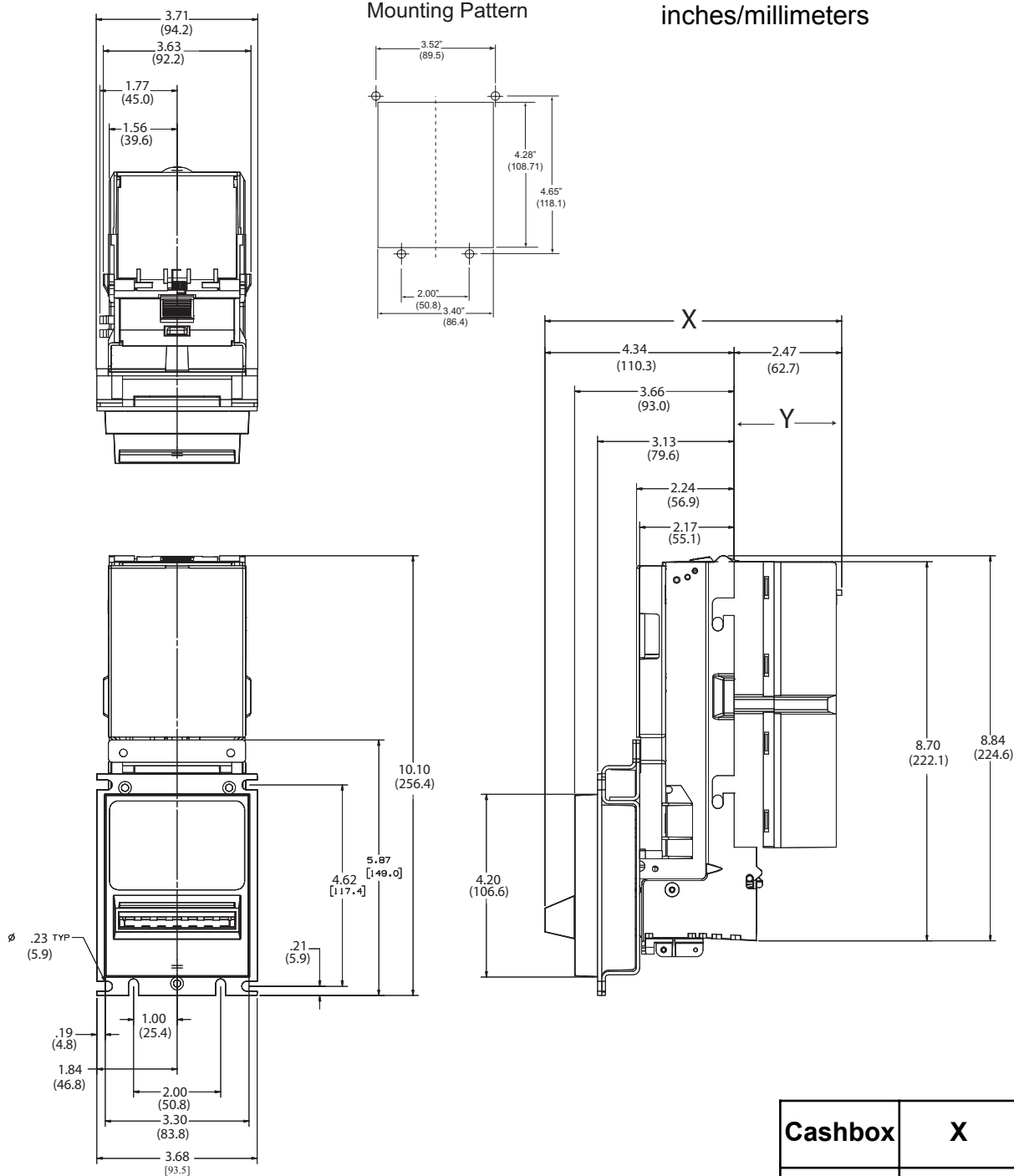

Cashbox	X	Y
300	6.81in. (172.9mm)	2.47in. (62.7mm)
500	7.02 (178.3)	2.68 (68.1)

# SECTION 4: COMPONENT EXPLANATION

## MC7200 with Standard Bezel

1. All dims shown are for reference purposes and are subject to manufacturing and assembly tolerances.
2. All dimensions shown are in inches/millimeters

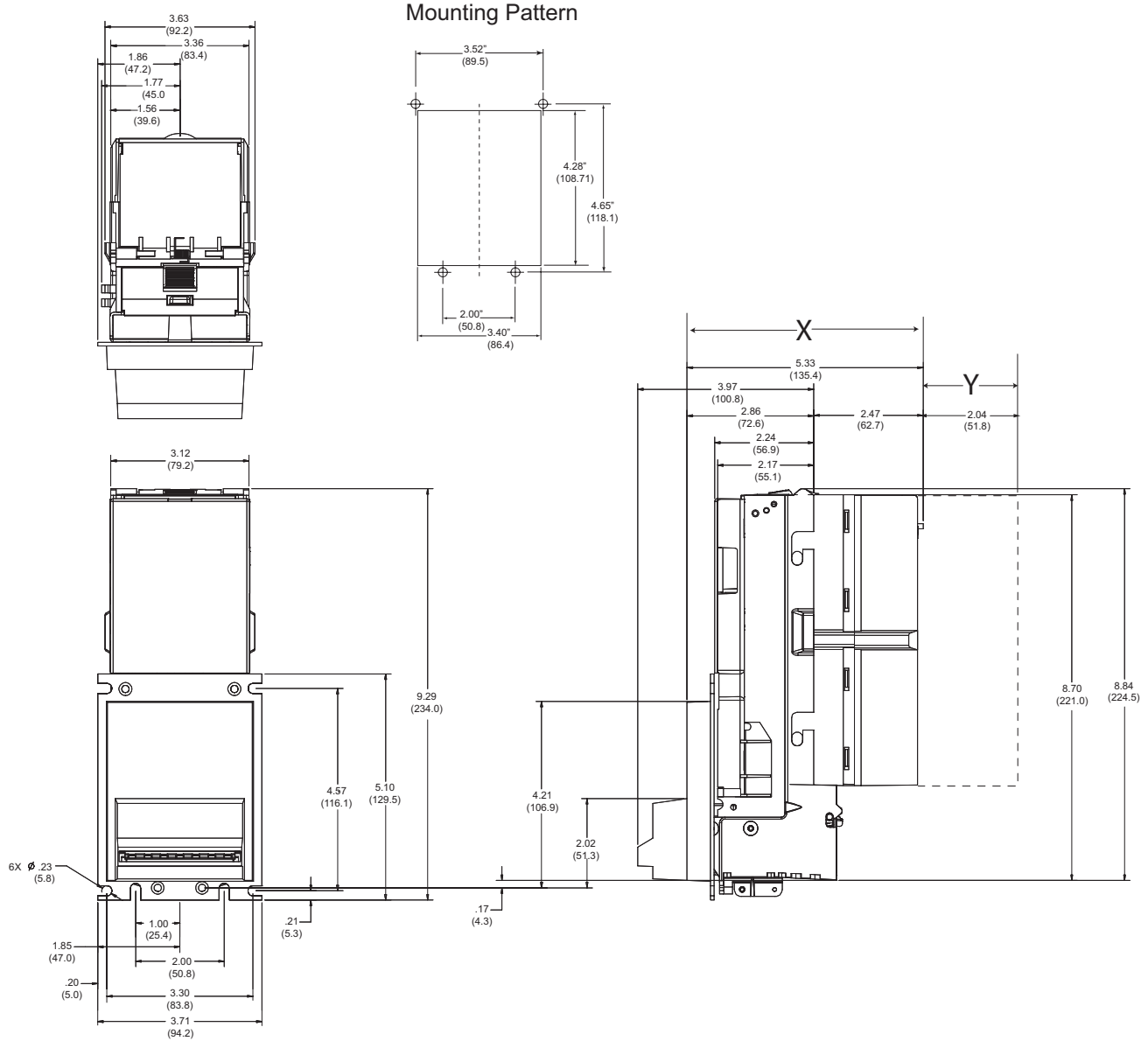

Cashbox	X	Y
300	5.33 in. (135.4 mm)	2.47 in. (62.7 mm)
500	5.54 (140.7)	2.68 (68.1)

## SECTION 4: COMPONENT EXPLANATION

### 30 Pin Mating Connector

Receptacle Housing: AMP 1-104482-3

Receptacle Pins: AMP 104479-2

Receptacle Polarizing Pins: AMP 87077-2

Pin	MCxxx1 110VAC	MCxxx2 24VAC
1	CREDIT_RELAY_COMMON	CREDIT_RELAY_COMMON
2	NOT USED	CREDIT_RELAY_NO
3	NEUTRAL_ENABLE	24VAC_HOT
4	110VAC_NEUTRAL	HOT_ENABLE
5	NEUTRAL_INHIBIT	KEY
6	KEY	MDB_MASTER_RX
7	TX_232	TX_232
8	INTERRUPT	INTERRUPT
9	CCTALK	CCTALK
10	SIGNAL_GROUND	SIGNAL_GROUND
11	DATA	DATA
12	ESCROW_HIGH	ESCROW_HIGH
13	232_EN/CCTALK_EN	232_EN/CCTALK_EN
14	NOT USED	MDB_MASTER_TX
15	ACCEPT_ENABLE_HIGH	ACCEPT_ENABLE_HIGH
16	CREDIT_RELAY_NO	DC_RETURN
17	NOT USED	NEUTRAL_INHIBIT
18	HOT_ENABLE	NEUTRAL_ENABLE
19	KEY	NOT USED
20	110VAC_HOT	24VAC_NEUTRAL
21	EARTH_GROUND	KEY
22	OUT_OF_SERV	OUT_OF_SERV
23	NOT USED	MDB_34VDC
24	ACCEPT_ENABLE	ACCEPT_ENABLE
25	OUT_OF_SERV_POWER	OUT_OF_SERV_POWER
26	SEND	SEND
27	ACCEPT_ENABLE_LOW	ACCEPT_ENABLE_LOW
28	NOT USED	MDB_SIGNAL_COM
29	RX_232	RX_232
30	ESCROW_LOW	ESCROW_LOW

### 18 Pin Mating Connector

Housing with Contacts: AMP 102398-7

Latching Front Cover: AMP 102681-4

Latching Back Cover: AMP 102536-7

Pin	MCxxx1 110VAC
1	CREDIT_RELAY_NO
2	INTERRUPT
3	CREDIT_RELAY_COMMON
4	SIGNAL_GROUND
5	SERIAL_DATA
6	ESCROW_HIGH
7	ARDAC2_ENA
8	NOT USED
9	NOT USED
10	OUT_OF_SERV
11	RX_232
12	ACCEPT_ENABLE
13	OUT_OF_SERV_POWER
14	SEND
15	TX_232
16	ACCEPT_ENABLE_LOW
17	ACCEPT_ENABLE_HIGH
18	ESCROW_LOW

### 6 Pin Mating Connector

Polarized Housing: AMP 87631-1 or 2-87977-8

Contact: AMP 85969-9 or 86016-3

Pin	110 VAC Power
1	CREDIT_RELAY_NO
2	INTERRUPT
3	CREDIT_RELAY_COMMON
4	SIGNAL_GROUND
5	SERIAL_DATA
6	ESCROW_HIGH

### 16 Pin Mating Connector

Polarized Receptacle Housing: VENSİK 5000 PAI-2x08

Receptacle Pins: VENSİK 4000-T-PS-T

Pin	MCxxx3 12V Multi-Interface	MCxxx4 12V Wake/Sleep
1	CREDIT_RELAY_NO	NOT USED
2	12VDC	12VDC
3	CREDIT_RELAY_COMMON	NOT USED
4	DC_RETURN	DC_RETURN
5	SIGNAL_GROUND	SIGNAL_GROUND
6	CC_TALK	NOT USED
7	232_EN/CCTALK_EN	NOT USED
8	MDB_COM	MDB_COM
9	MDB_MASTER_TX	MDB_MASTER_TX
10	MDB_MASTER_RX	MDB_MASTER_RX
11	RX_232	NOT USED
12	ESCROW_LOW	NOT USED
13	ESCROW_HIGH	NOT USED
14	TX_232	NOT USED
15	ACCEPT_ENABLE_HIGH	NOT USED
16	ACCEPT_ENABLE_LOW	NOT USED

## SECTION 5: DISASSEMBLY

---

### Tools needed:

- #2 Phillips head screwdriver
- Flat head screwdriver
- 3/16" nut driver
- 1/8" nut driver
- 9 volt battery and battery connector harness

### Remove Cashbox Assembly

1. Slide red button located on the top of the unit forward. Lift up and pull back on cashbox assembly. (Figure 3)



## SECTION 5: DISASSEMBLY

### Removing motors from stacking assembly

1. Apply power, insert business card into bill inlet until stacker plate extends to fullest height. Remove power. (Figure 4)

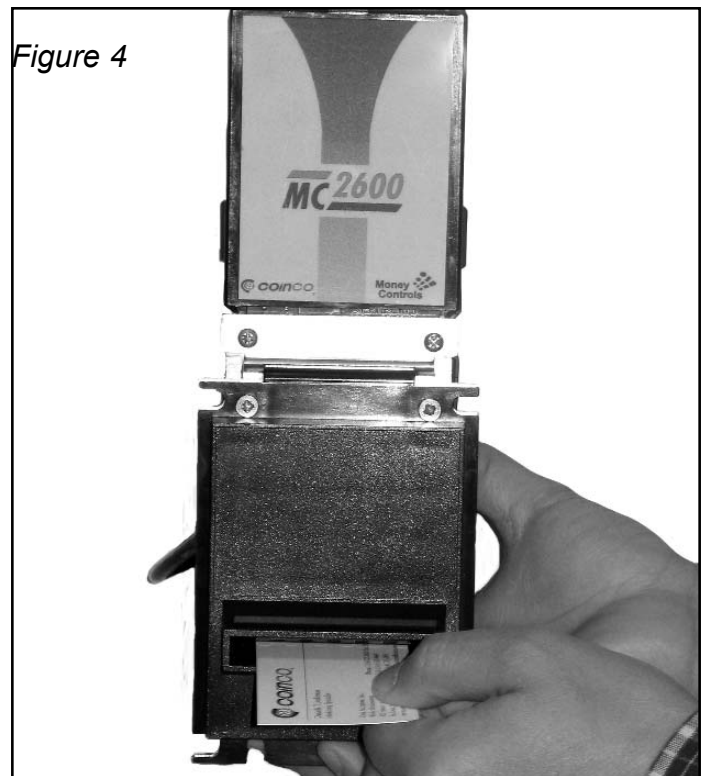

### Removing the Bezel

Using a Phillips screwdriver, remove the screws that secure the bezel and frame to the chassis assembly. (Figure 5)

- Slimline Bezel - 3 screws, 3 nuts
- Standard Bezel - 4 screws
- Slimline Frame - 4 screws

Disconnect ground wire from metal frame.

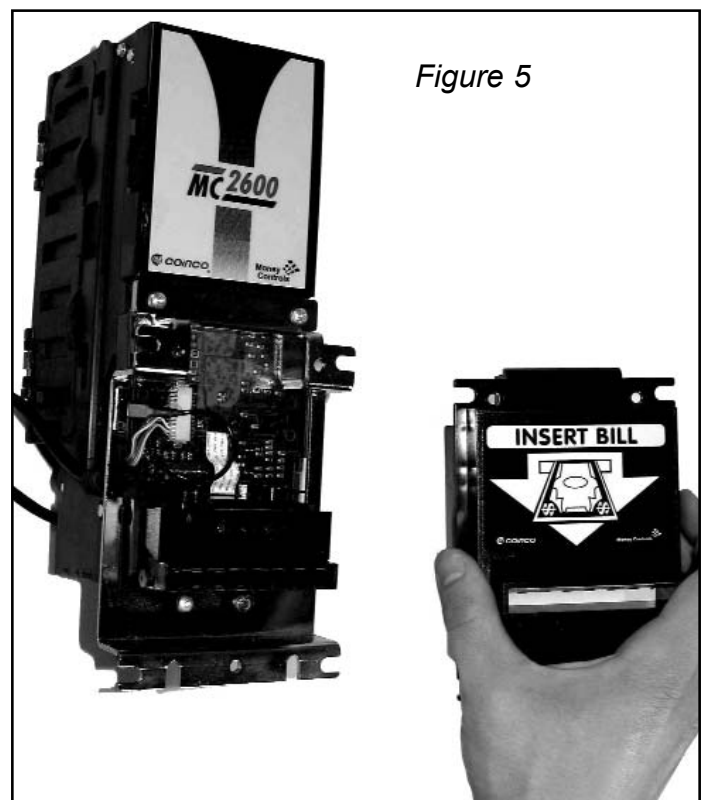

## SECTION 5: DISASSEMBLY

### IMPORTANT

Note the plastic shield that appears on the metal.  
(See Fig. 6--Slimline example)

When re-attaching, make sure the clear plastic shield is against the PC board to prevent shorting the microboard.

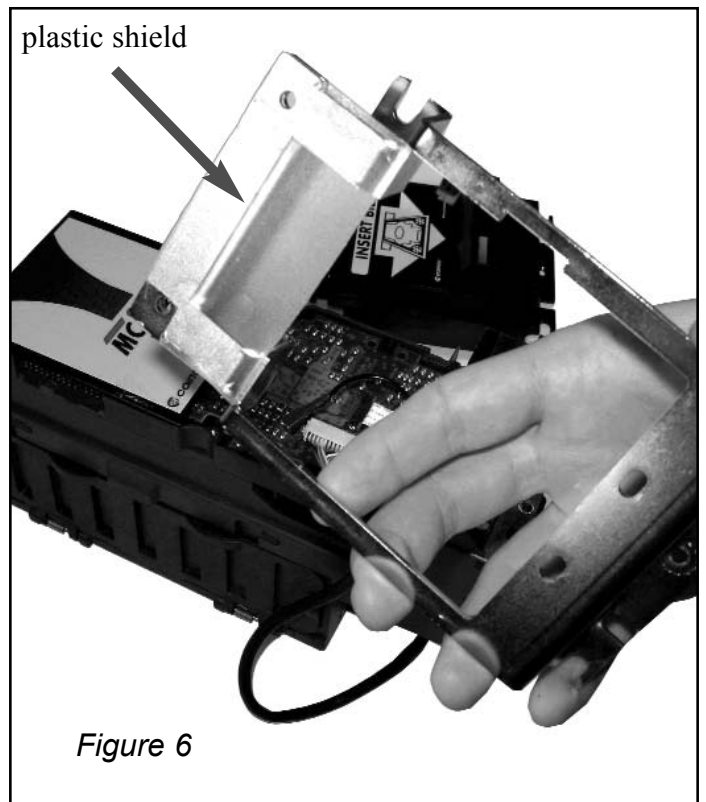

### Removing the Front Cover

To remove front cover to expose the microboard, push down the snap located on the top of the unit. (Figure 8)

Pull the front cover forward.

Note--Removing the front cover will void the warranty.

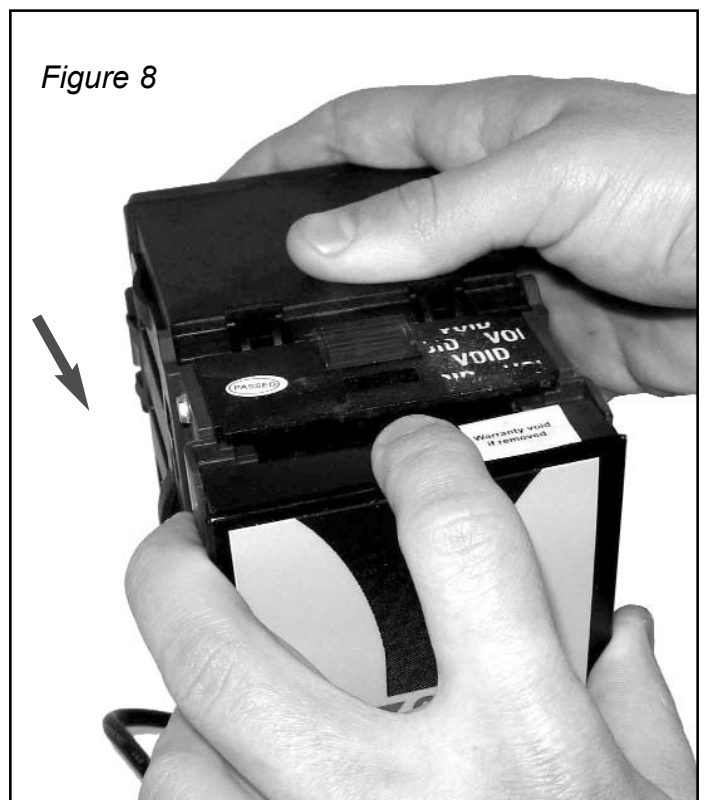



## SECTION 5: DISASSEMBLY

### Removing Harnesses from the microboard from Bottom sensor assembly (Figure 9)

1. Unplug Bottom Sensor Assembly harness from Microboard.
2. Release harness from chassis clamps on the side.

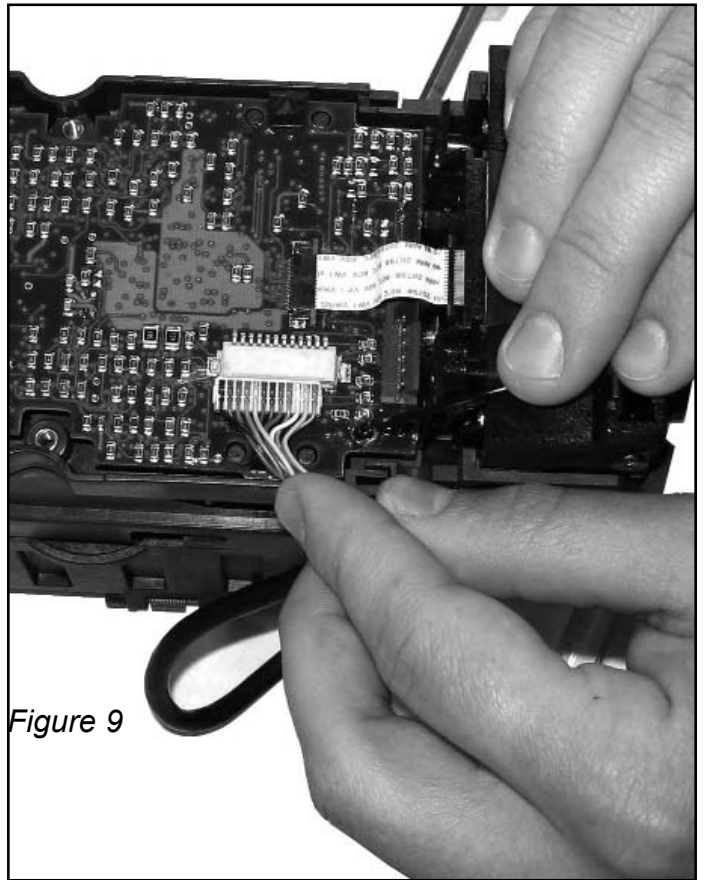

Figure 9

### Remove Bottom Sensor Assembly

1. At bottom rear of unit, push down on red tab and slide out bottom sensor assembly. (Figure 10)

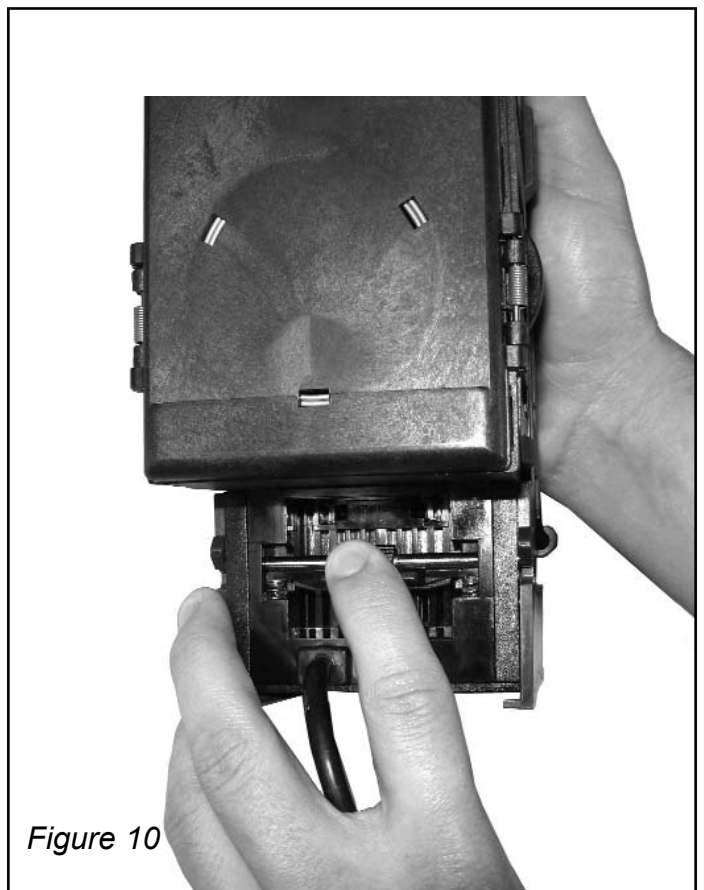

Figure 10

## SECTION 5: DISASSEMBLY

### Remove Bottom Sensor Assembly

1. At the bottom and rear of unit, push down on red tab and pull out bottom sensor assembly. (Figure 11)

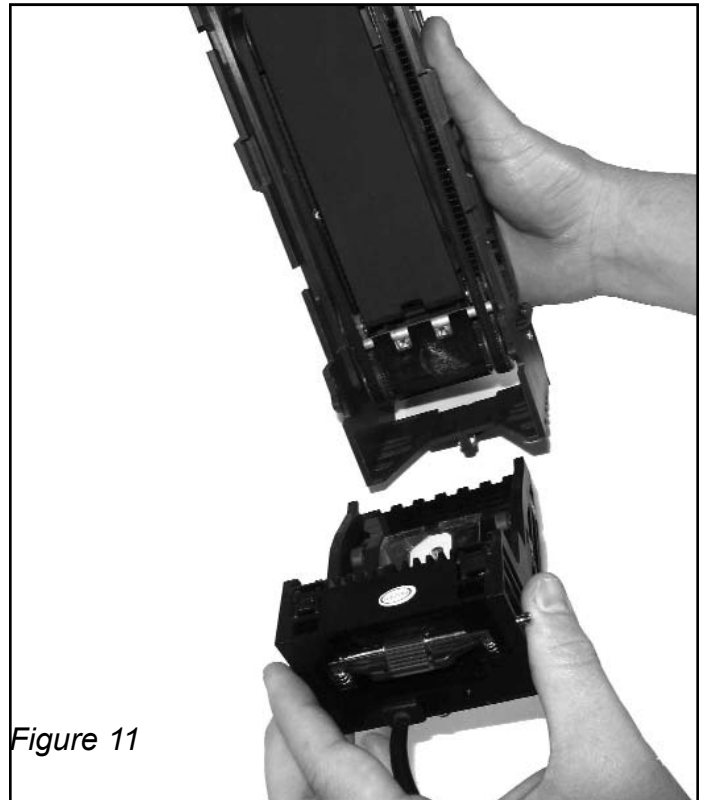

Figure 11

### Removing Microboard (Figure 12)

1. Remove ribbon cable by sliding the plastic connectors to the open position.
2. Gently pull ribbon cable from microboard connector.

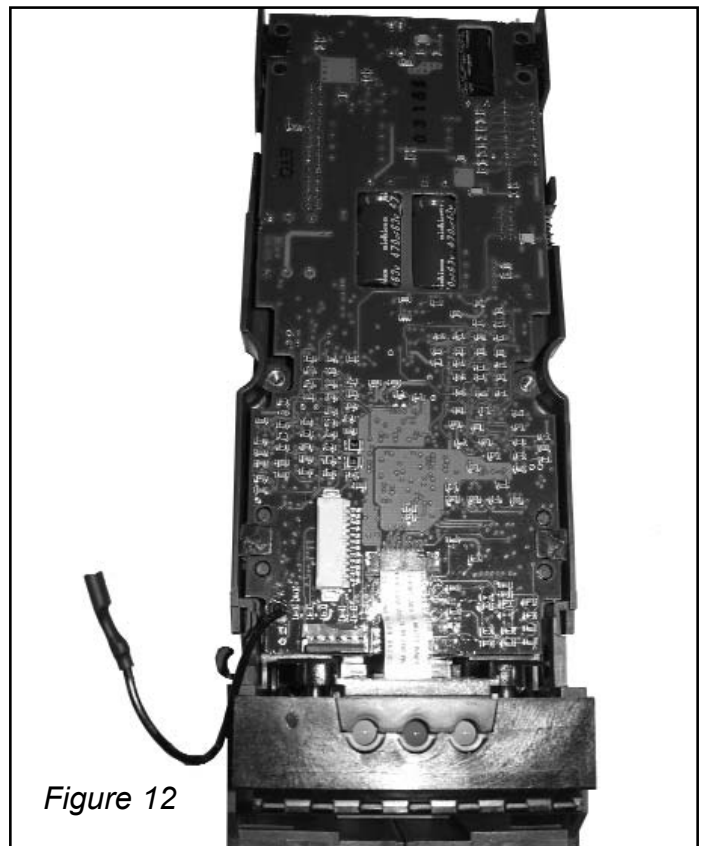
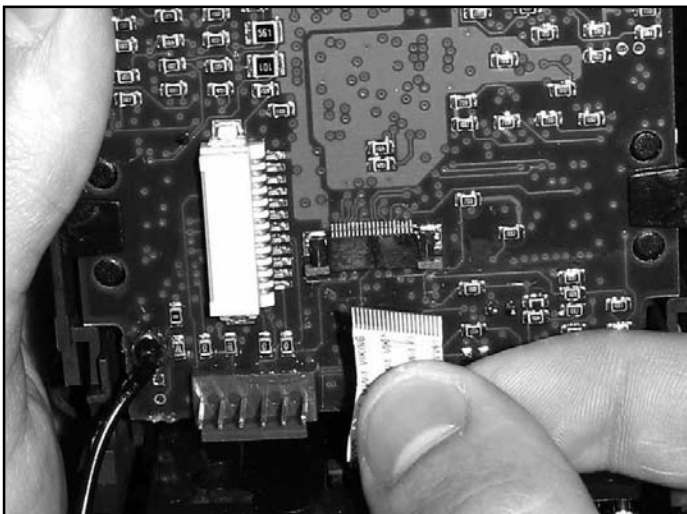

Figure 12

## SECTION 5: DISASSEMBLY

Figure 13--Plastic Connectors in closed position.

Closed Position

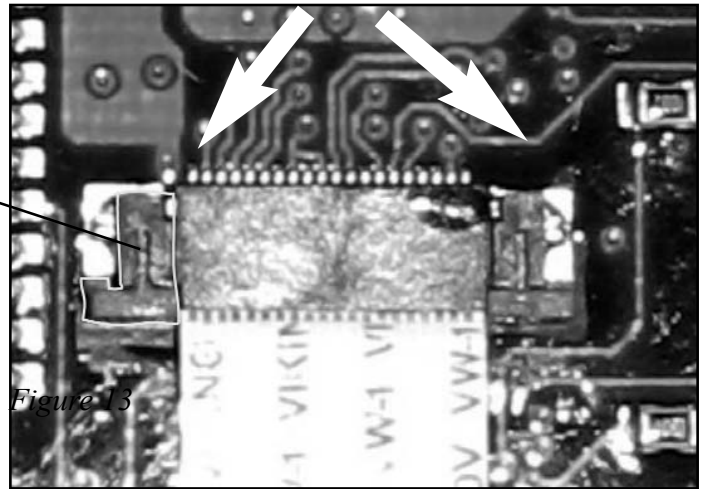
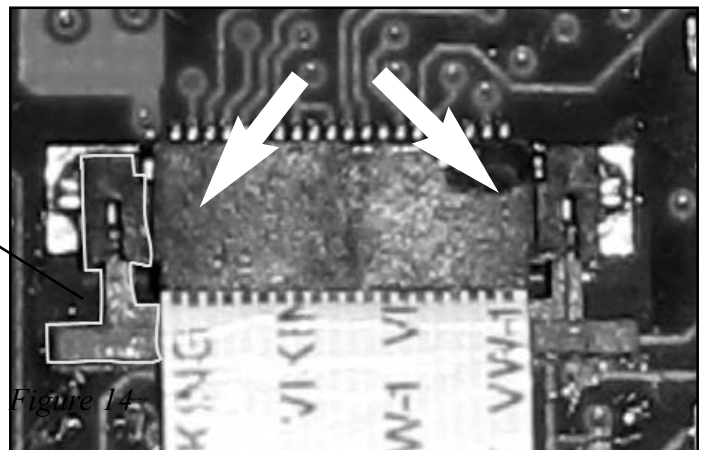

Figure 14--Plastic connectors in open position

Open Position



## SECTION 5: DISASSEMBLY

Figure 15--Using a small flathead screwdriver, carefully pry the board out at the four corners indicated.

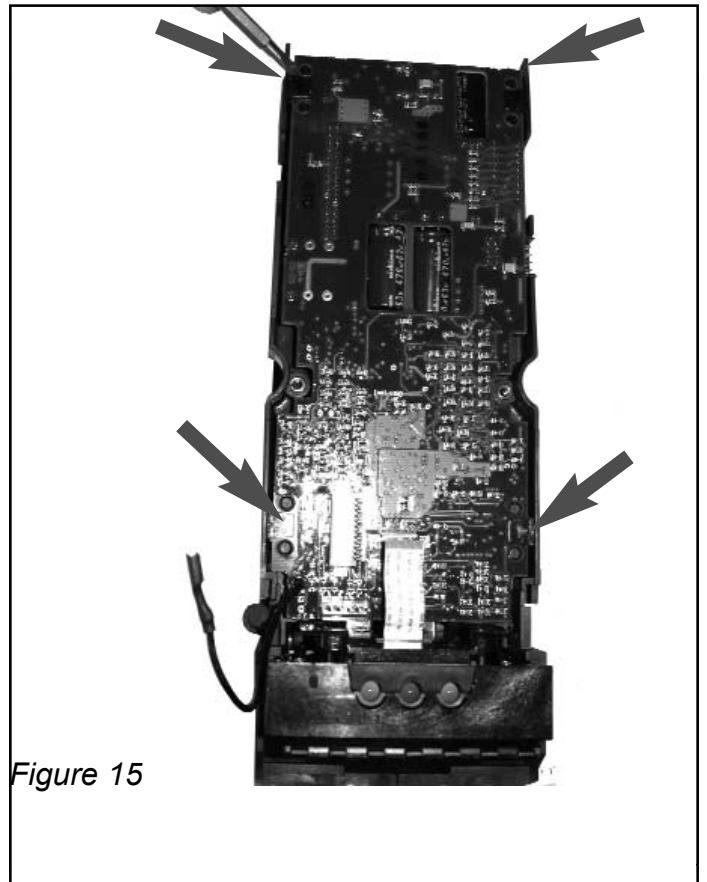

Figure 15

Figure 16-- Note the attached motor connection wires.

Unplug the stacker motor (white & red) wires and transport motor (white & blue) wires from the microboard.

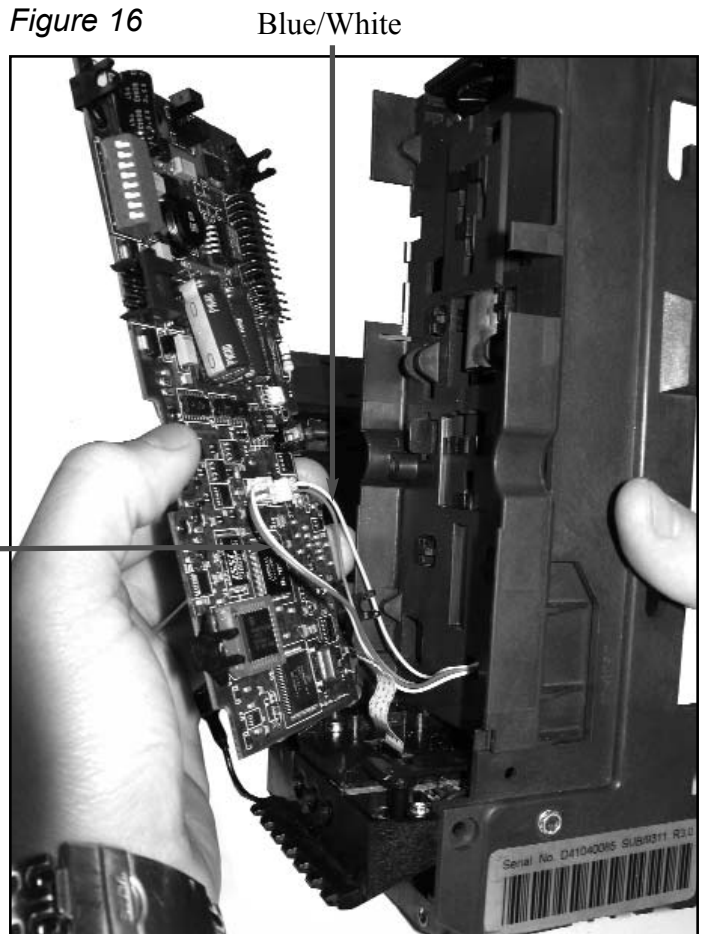

Figure 16

Blue/White

Red/White

## SECTION 5: DISASSEMBLY

### Removing Drive and Stacker Chassis Assembly

1. Make sure stacker plate is fully retracted into unit.
2. Using phillips screw driver, remove one nut from left and right side of the housing as shown. (Figure 17)

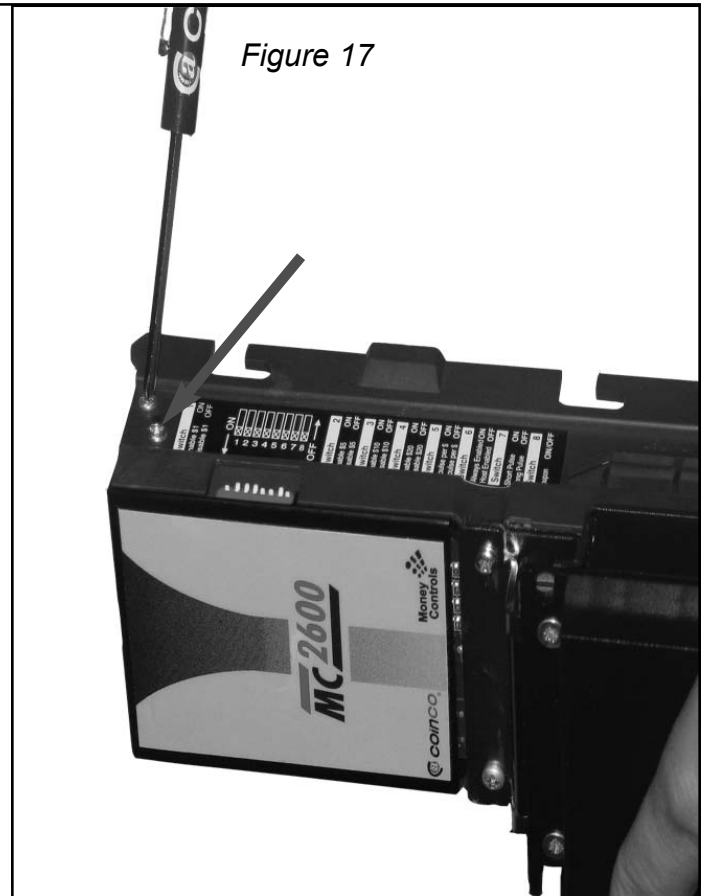

3. Pull Drive and Stacker Chassis forward to lift out of housing. (Figure 18)

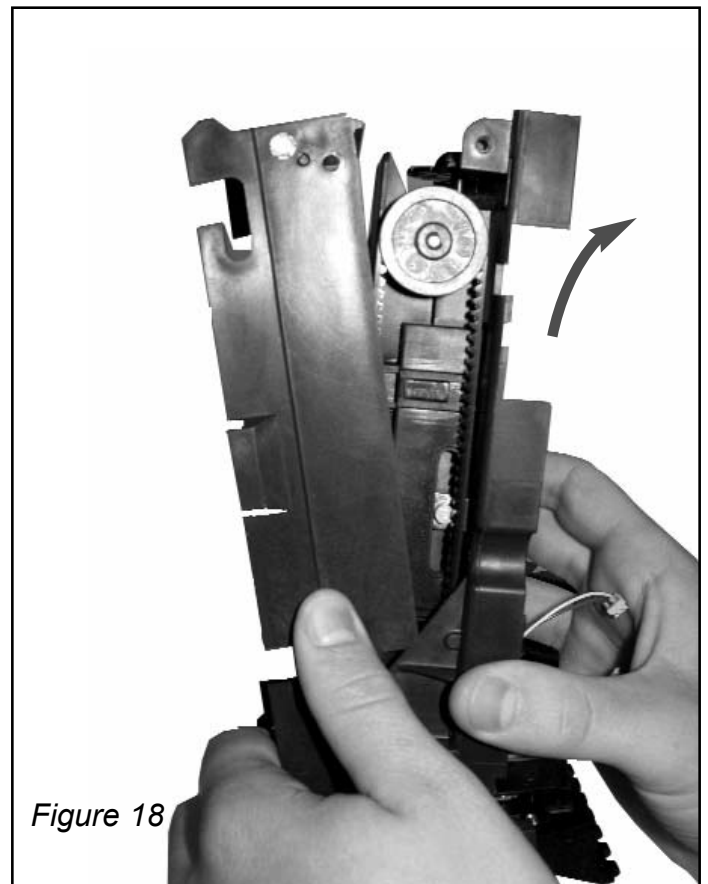

## SECTION 5: DISASSEMBLY

### Removing Top Sensor Assembly from housing.

1. Using 3/16" nut driver, unscrew bolts from both sides of housing. (Figure 19)
2. Push down Top Sensor Assembly until assembly clears the side housing notches. Pull assembly straight forward.

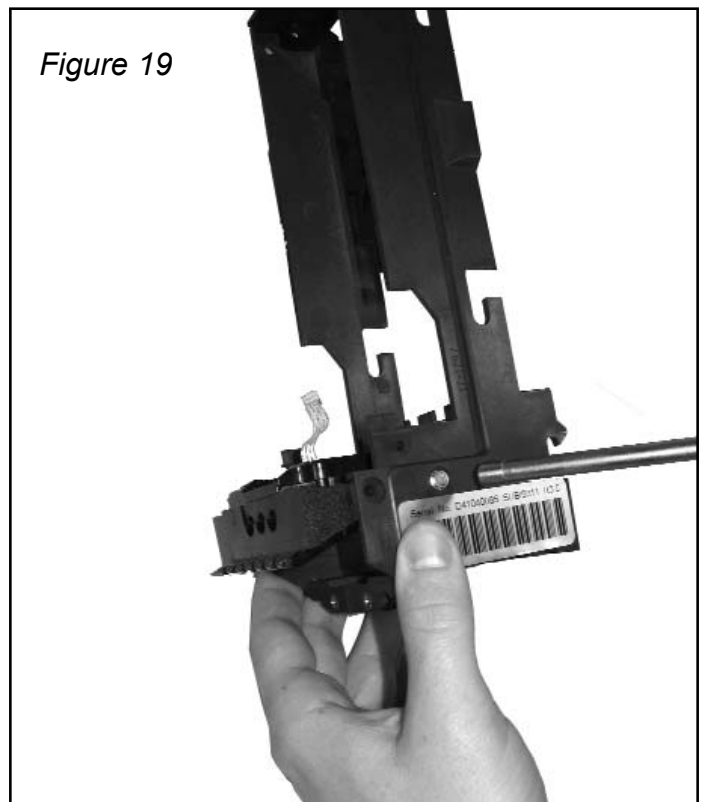

### Removing Stacker Plate

1. Look for plastic tab on one side of the assembly. This indicates the correct side to begin stacker plate removal. (Figure 20)

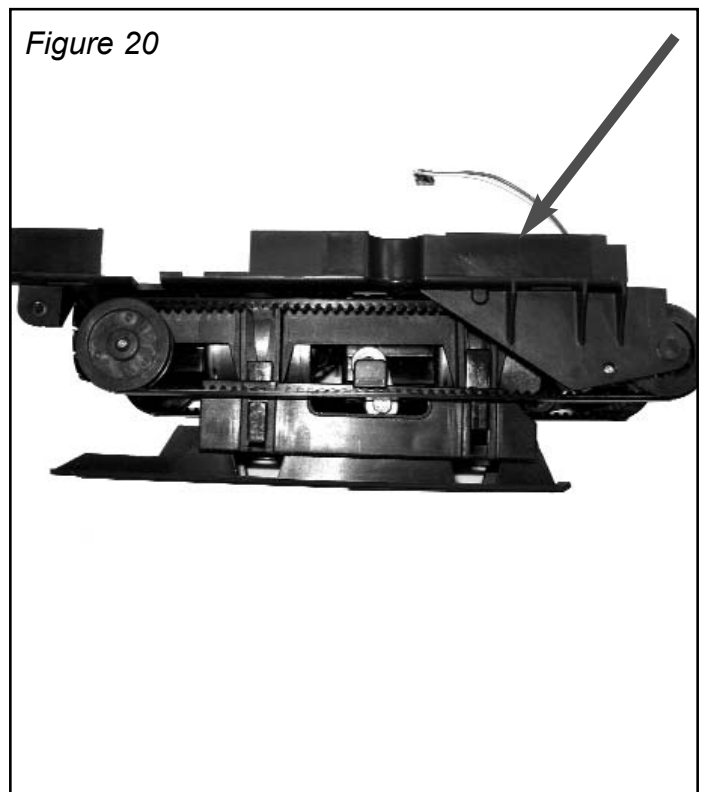

## **SECTION 5: DISASSEMBLY**

Do not pull or push the plastic tab, which will break it. (Figure 21)

2. Pull out this side of the stacking plate, clearing the cam. Then remove plate (Figure 22)

*Figure 21*

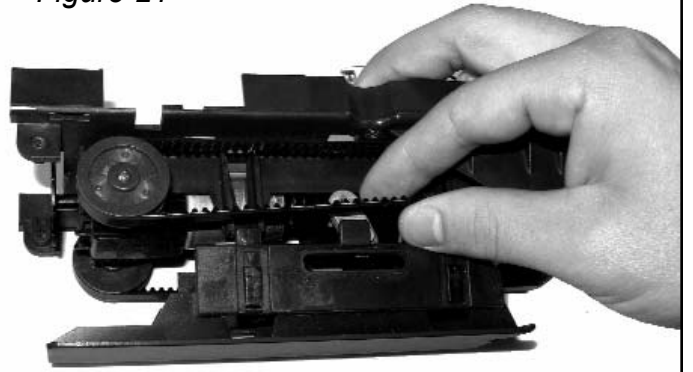

*Figure 22*

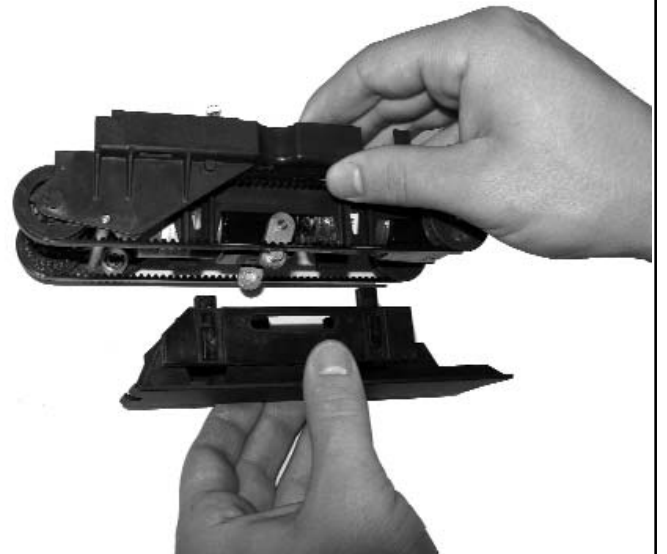

## SECTION 5: DISASSEMBLY

### To Remove Belts

1. Squeeze stacker motor spring (Figure 23) to clear stacker motor gearbox snap fits on reverse side (Figure 21).

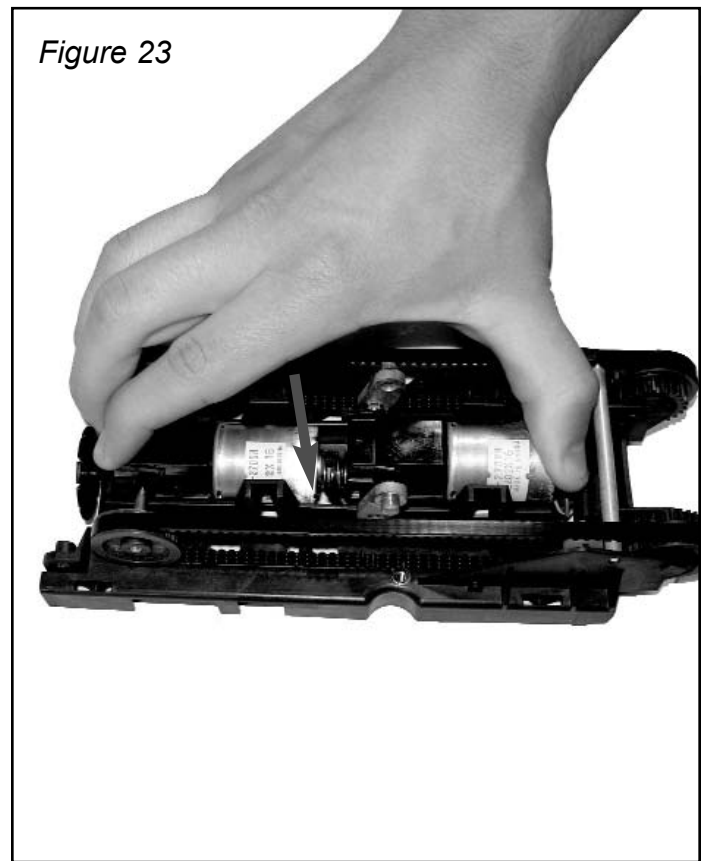
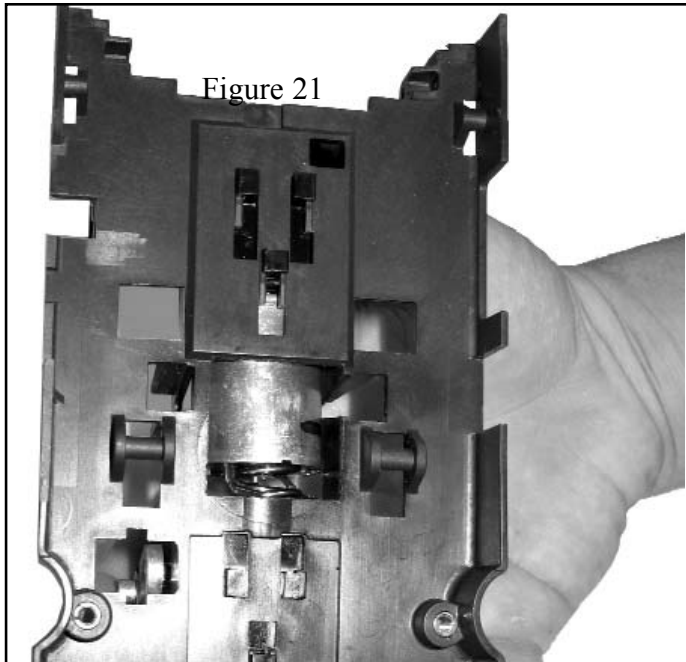

1. Remove belts from transport gears. (Figure 24)

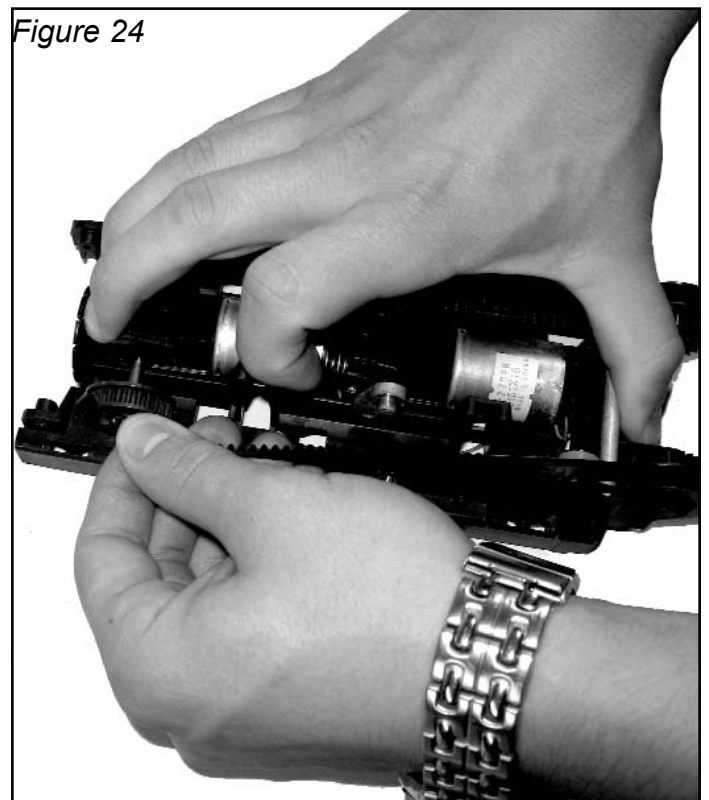



## SECTION 5: DISASSEMBLY

### Removing Belts

2. Use screwdriver to push out retaining pin and remove belts. (Figure 25)

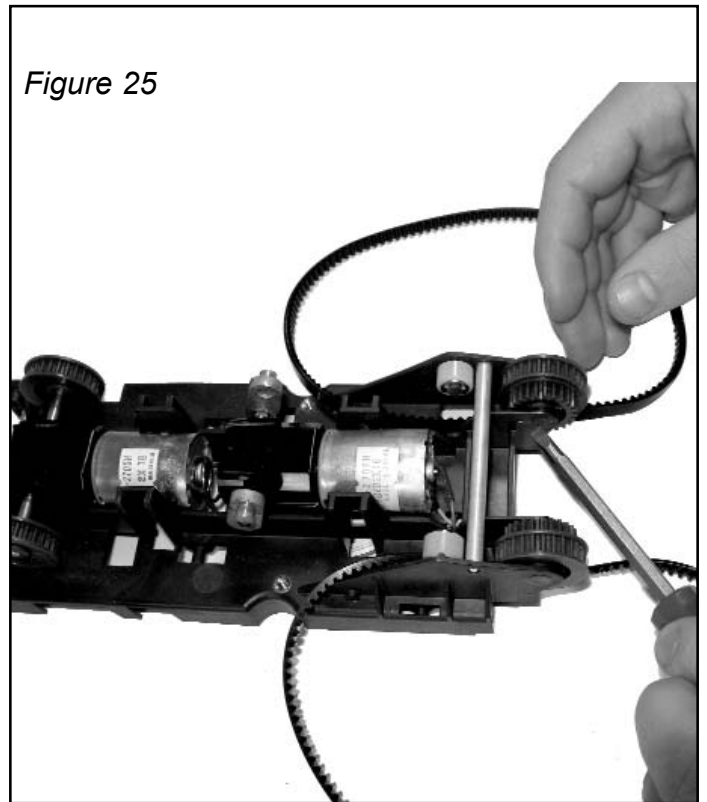
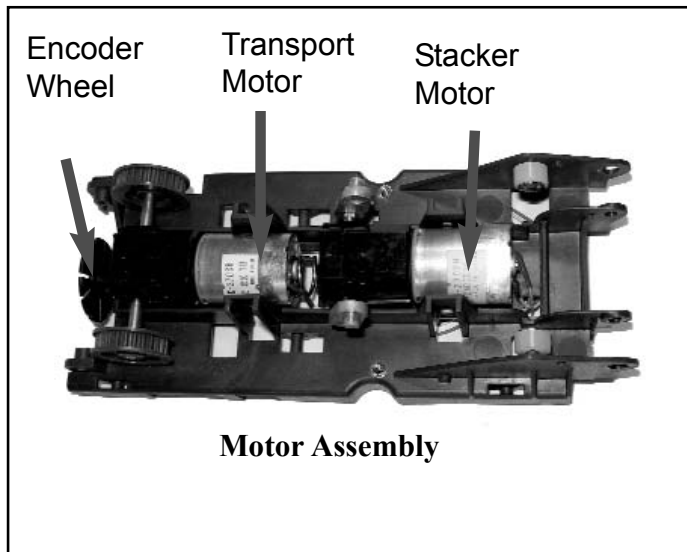

Figure 25

Retaining pin removed (Figure 26)

Belts fully removed from unit.



Motor Assembly

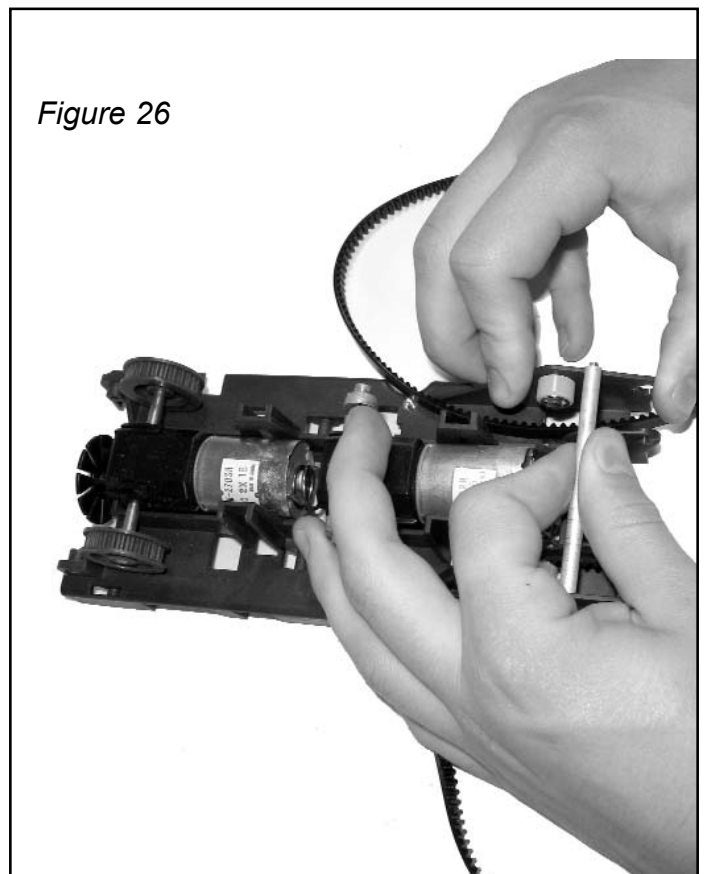
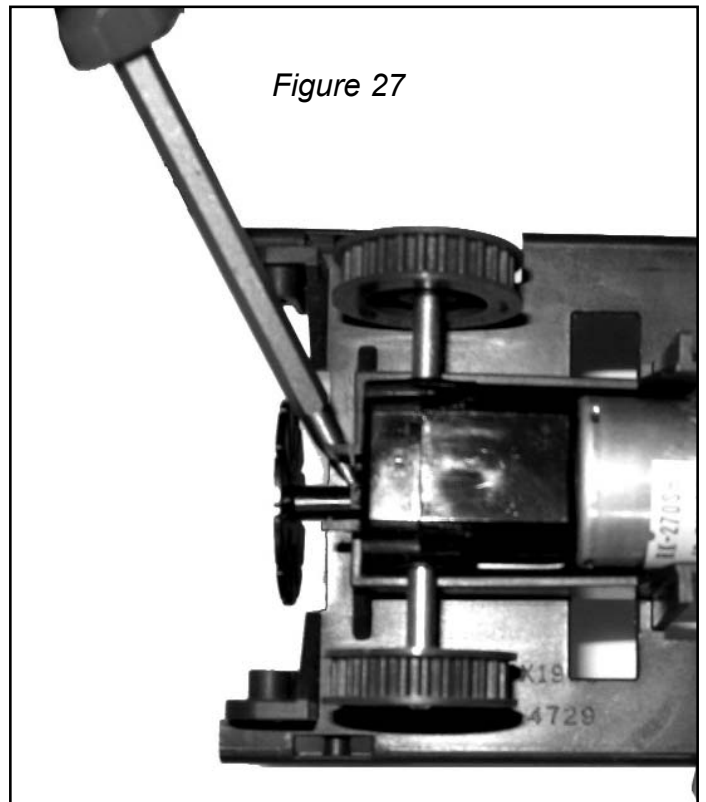

Figure 26

## SECTION 5: DISASSEMBLY

### Remove encoder wheel

1. Using flat head screwdriver, pry encoder wheel from base of transport motor gearbox.



Encoder wheel removed.

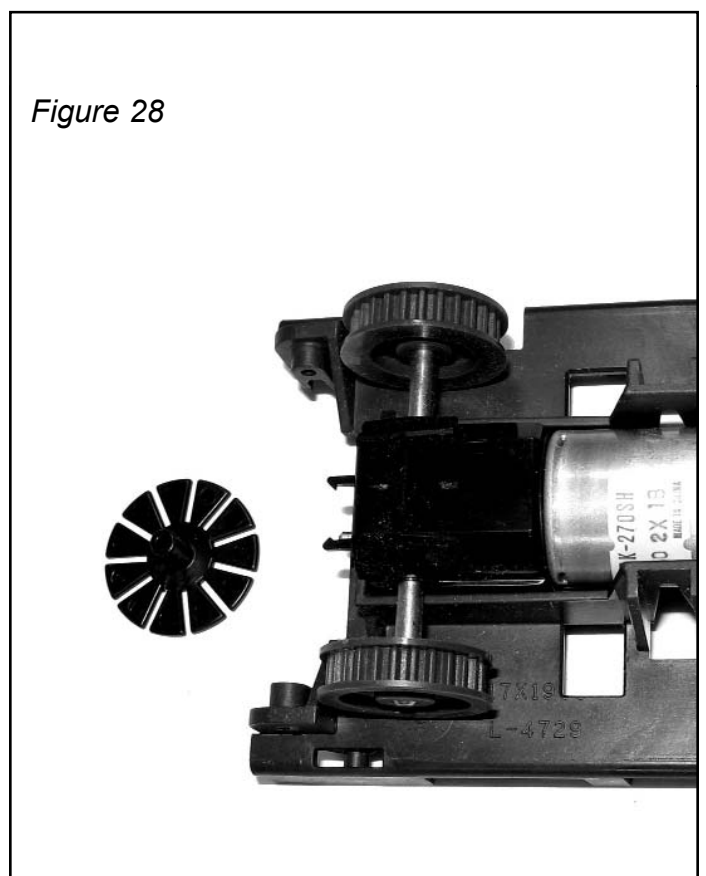

## SECTION 5: DISASSEMBLY

### Removing motors

1. Push stacker motor in to clear reverse side snap fit notches and lift out.

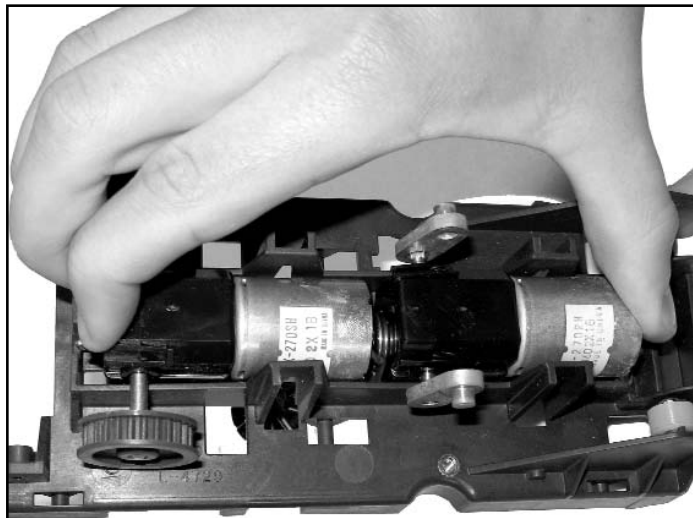

*Figure 29*

2. Pull remaining transport motor straight out.

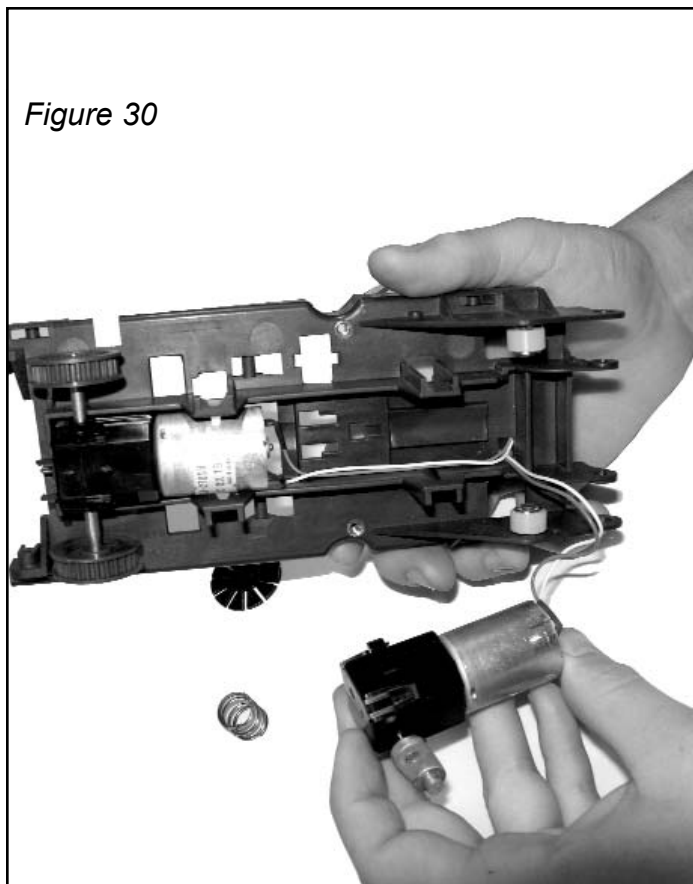
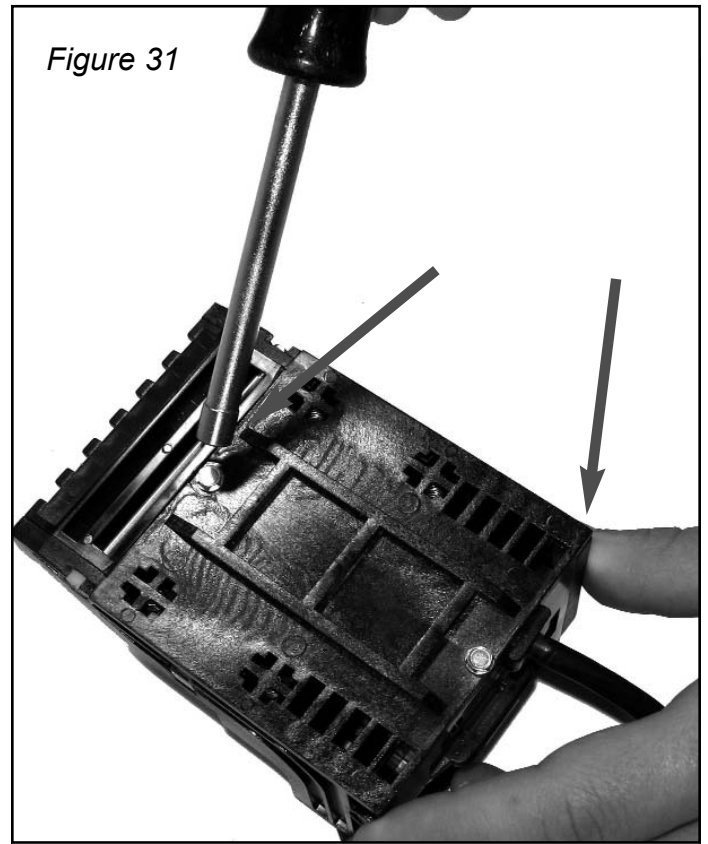

*Figure 30*

## SECTION 5: DISASSEMBLY

### Disassembling the Bottom Sensor Assembly

1. Using 3/16" nut driver, remove two nuts as shown.
2. Once nuts are removed, hold plate down to keep the four springs from jumping out.



Bottom plate removed exposing springs and sensor board.

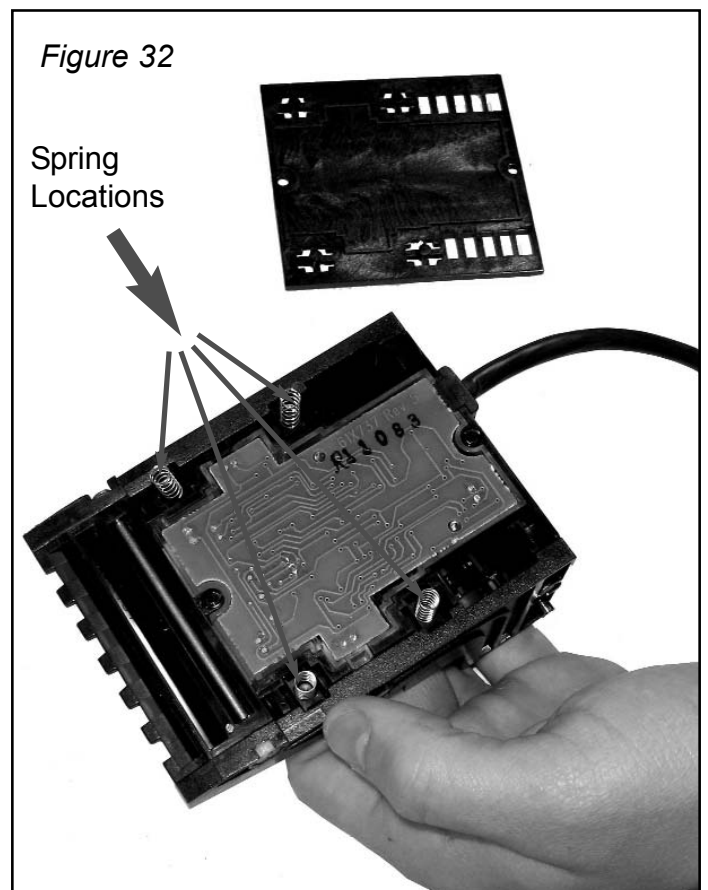

## SECTION 5: DISASSEMBLY

1. Pull sensor board straight out to remove from housing.

Figure 33

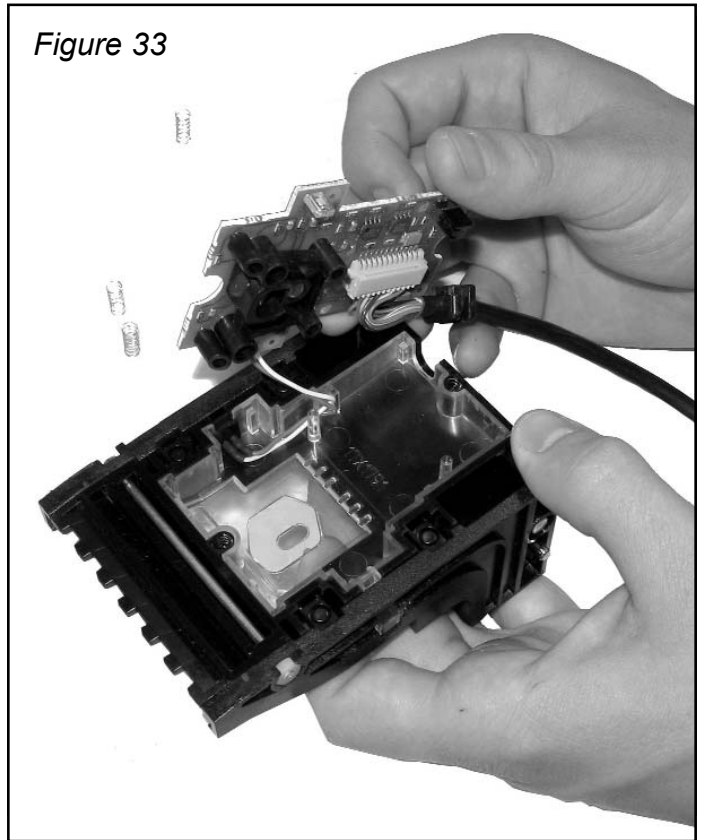

### Removing side sensor

1. Note that bottom sensor board is still connected to bottom plate assembly housing.
2. Note location of side sensor.
3. Remove screws located on this side.

Figure 34

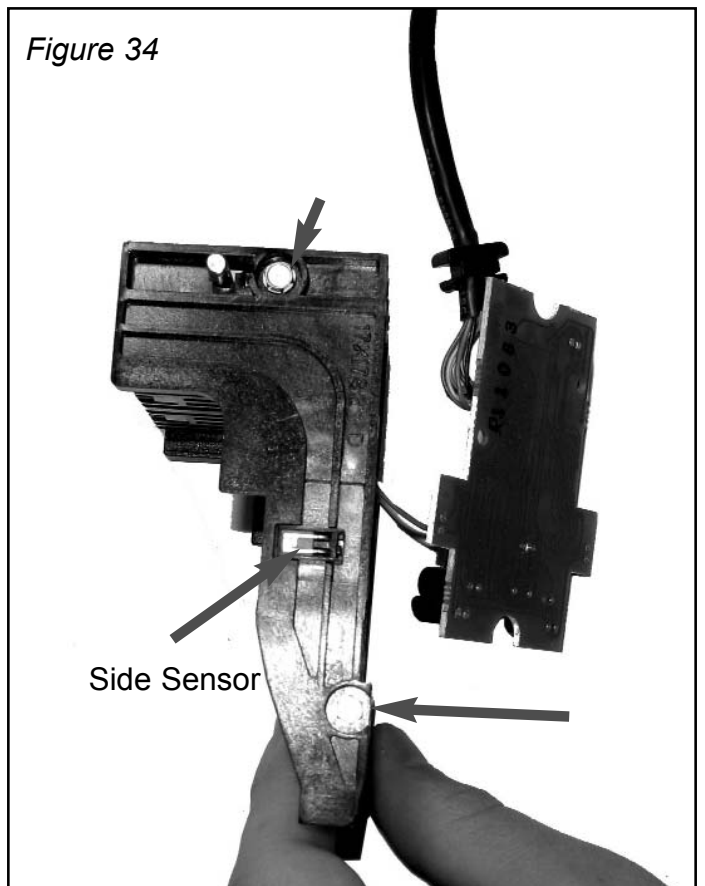

## SECTION 5: DISASSEMBLY

4. Note pin in front.

1. Unscrew nuts on either side of front pin and remove pin.

2. Unscrew nuts on either side of rear pin and remove pin.

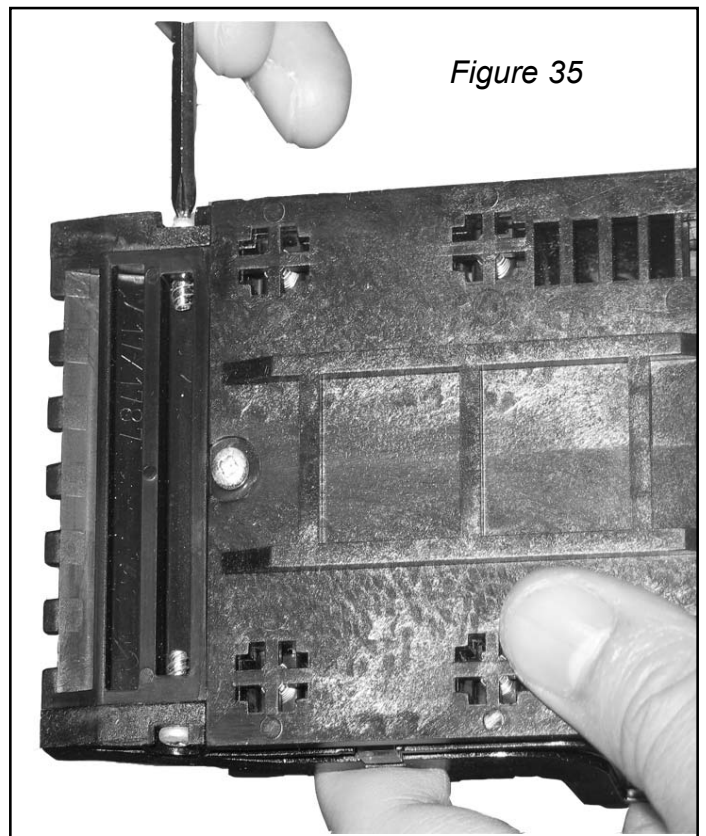

Side Plate is removed.

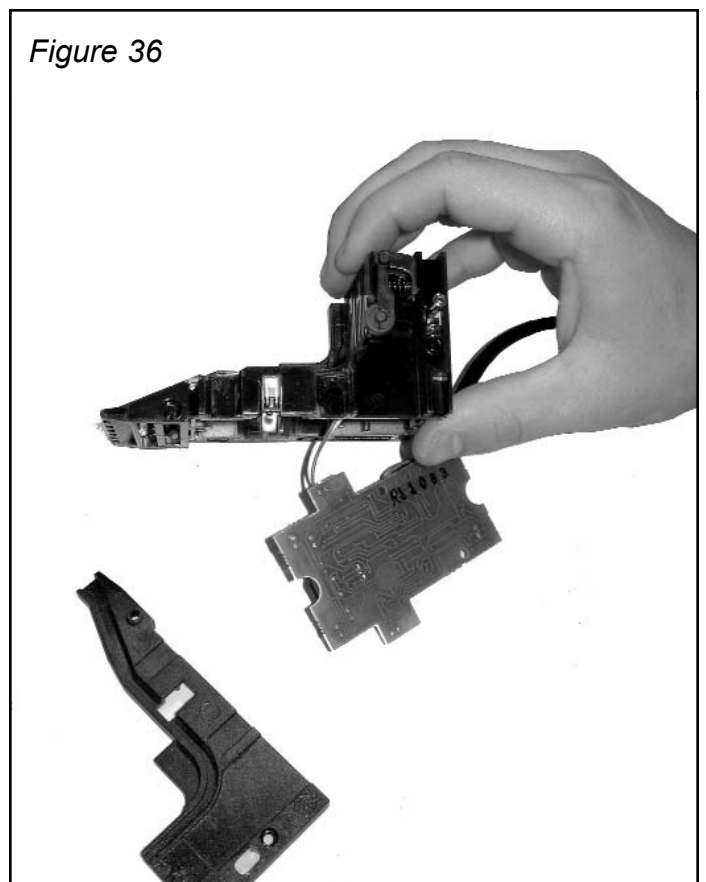

## SECTION 5: DISASSEMBLY

Pull out side sensor.

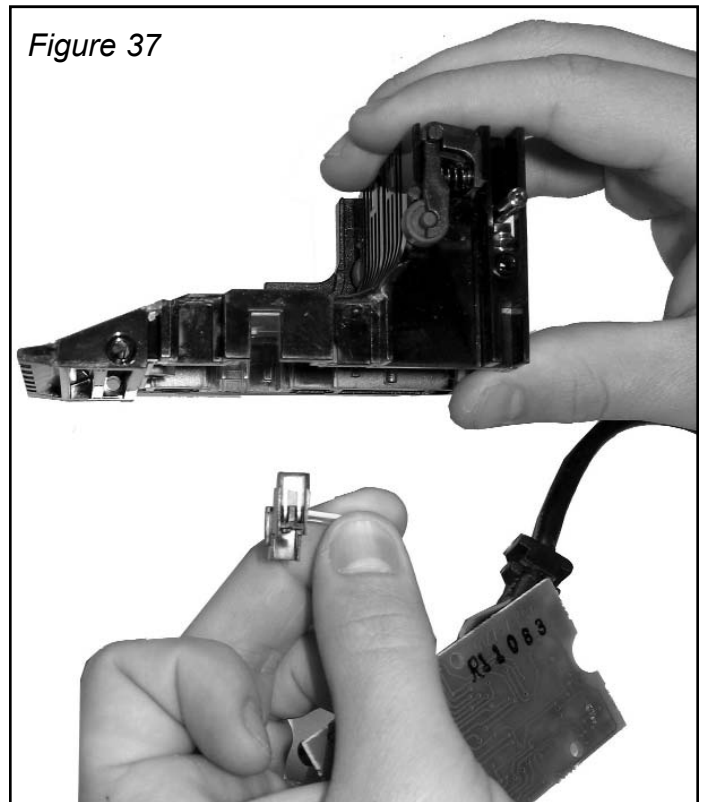

### Removing Top Sensor Board

1. Using 1/8" nut driver, remove 3 screws (Fig 38).
2. Remove Plastic cover, exposing top sensor board.

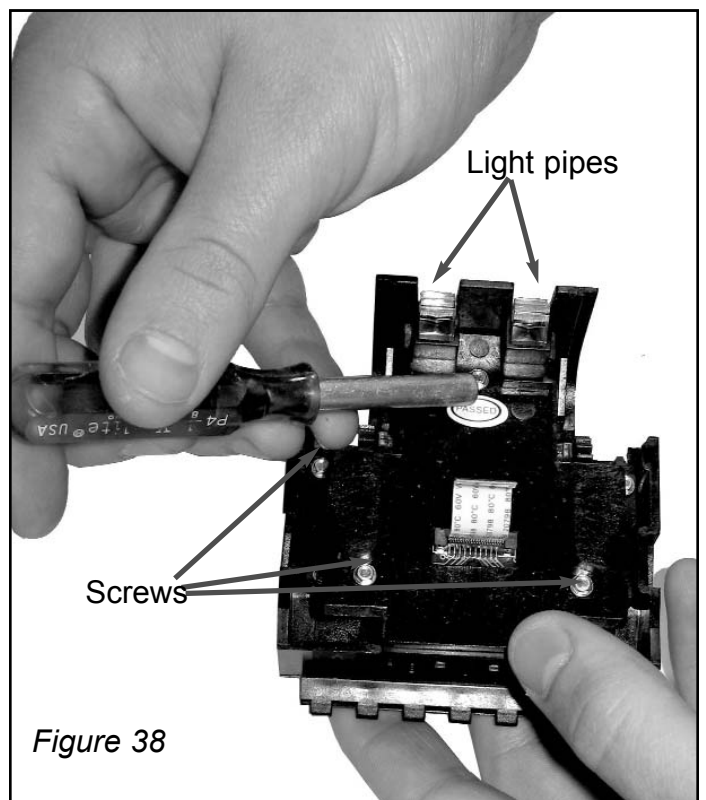

# SECTION 6: PARTS LIST

See Page 33

MC Series Mask Options

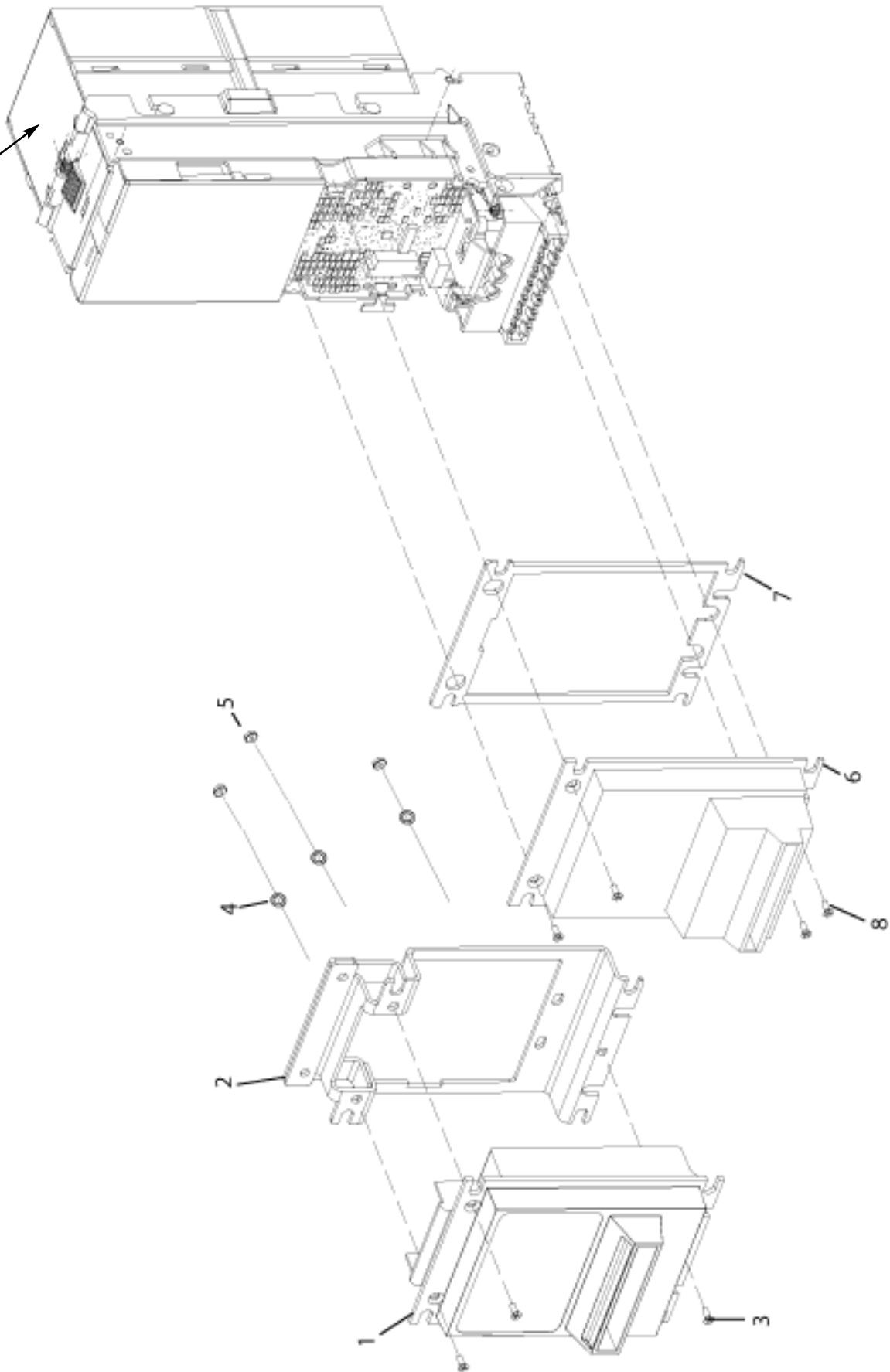



## SECTION 6: PARTS LIST

Item #	Description	2600/2800 Part No.	QTY.	7200 Part No.	QTY.
1	Mask, Slimline	925882	1	PBL/1669	1
2	Adapter, Slimline Mask	MET/290	1	MET/290	1
3	Screw, M4X12	HSC/326	3	HSC/326	3
4	Washer, 4mm	HWA/026	3	HWA/026	3
5	Nut, M4	HNT/010	3	HNT/010	3
6	Mask, Standard	PBL/1594	1	PBL/1633	1
7	Mask, Frame, Standard	MET/289	1	MET/289	1
8	Screw, 6-32x5/8	300317	3	300317	3
9	MC Series Download Box	409023	1	409023	1

### Service Tools - MC Series Download Box

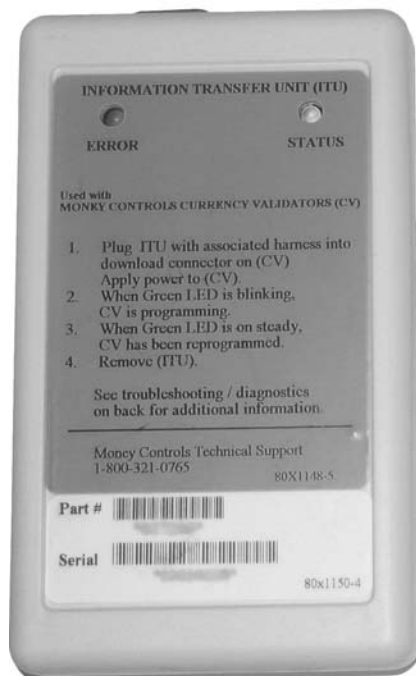

Part 9

# SECTION 6: PARTS LIST

## MC Series Drive Chassis Assembly

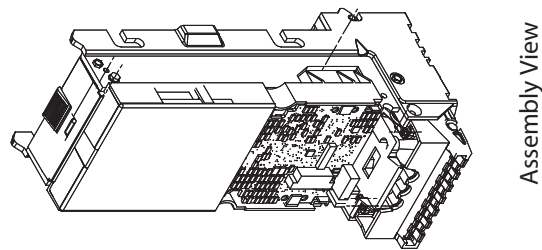

Assembly View

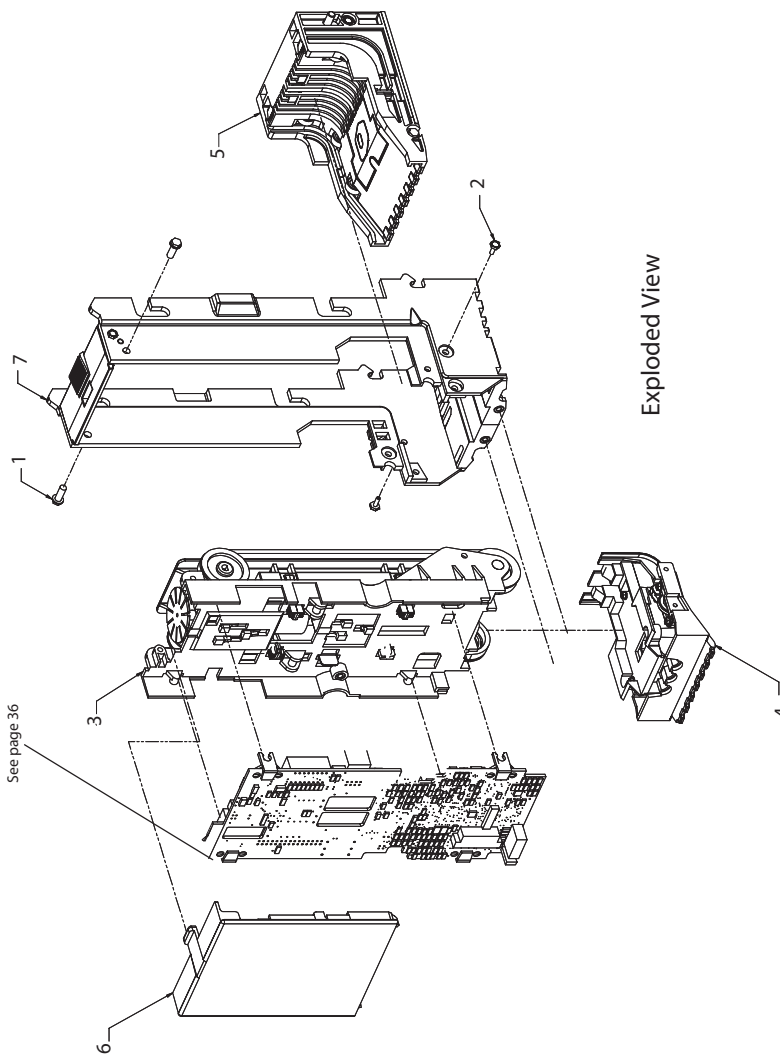

Exploded View

ITEM	Description	MC2600/2800 Part No.	QTY.	MC7200 Part No.	QTY.
1	Screw, 6-19x.975IH/WSTS HI LO	300290	2	HSC/103	2
2	Screw, 4-24 x.250 I.H./W.H.	300339	2	HSC/104	2
3	S.A. Drive & Stacker Chassis	409046	1	SUB/9406	1
4	Top Sensor Assembly	409043	1	409043	1
5	Bottom Sensor Assembly	409042	1	409042	1
6	CVR, Plate UPR FRT Lexan FR	1709450001	1	1709450001	1
7	Chassis Assembly	021765A	1	409055	1

See page 36

## SECTION 6: PARTS LIST

### DRIVE AND STACKER CHASSIS

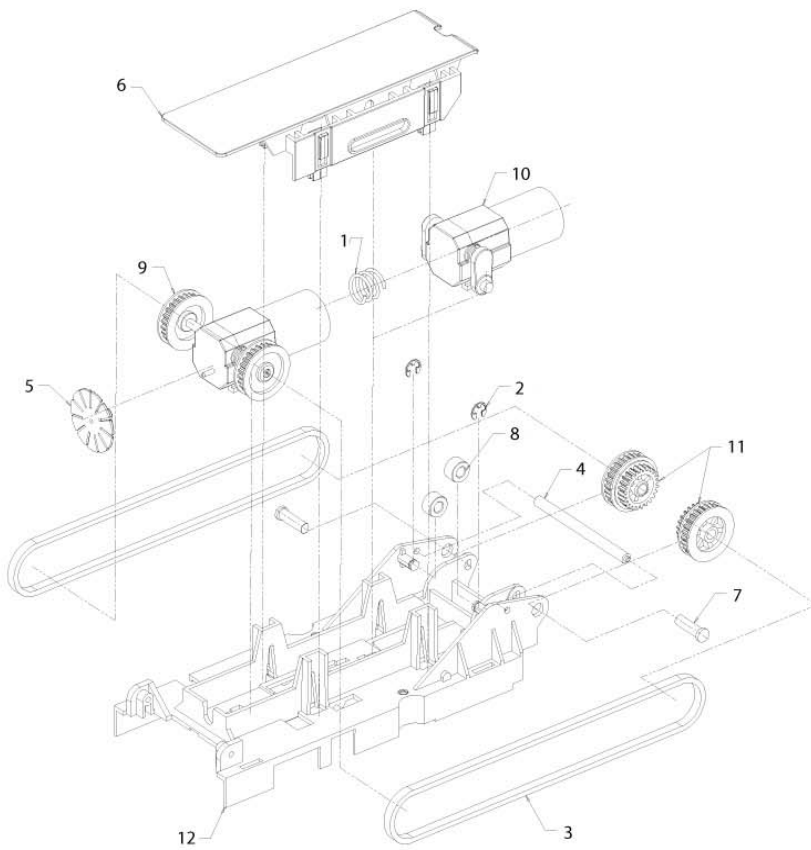

EXPLODED VIEW

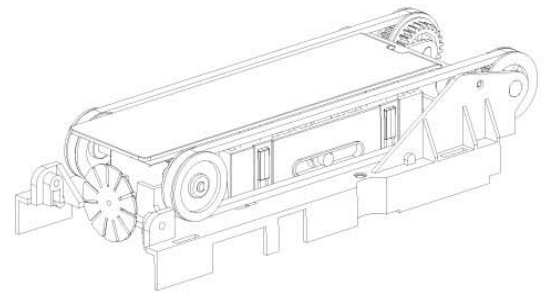

ASSEMBLY VIEW

ITEM	DESCRIPTION	2600/2800 Part No.	QTY.	7200 Part No.	QTY.
0	Assembly	409046	-	SUB/9406	-
1	Spring, Belt Tension	SPR/147	1	SPR/147	1
2	E-Ring, .188 Shaft	310036	2	310036	6
3	Belt, Drive 3mm 3/16 Wide	290187	2	HRB/005	2
4	Shaft, Motor Chassis	200919	1	200919	1
5	Wheel, Chopper 11 Slot	171975	1	171975	1
6	Punch Plaste Assy, ABS silicone coated	SUB/9330	1	171969	1
7	Shaft, Idler Pulley	171714	2	PBL/1683	2
8	Roller Back-up 3mm sys.	PBL/1689	2	171695	2
9	Drive, motors, w/ pulleys assy.	027233A	1	027233A	1
10	Stacker, Motor assy.	027188	1	027188	1
11	Gear & Flange assy.	027169A	2	027169A	1
12	S.A. Chassis & Thread Insert	409045	1	409045	1
13	Pulley Plate RH	N/A		PBL/1626	1
14	Pulley Plate LH	N/A		PBL/1625	1
15	Slider	N/A		PBL/1668	4

## SECTION 6: PARTS LIST

### MC Series PC Boards and Harnesses

#### MC Series PC Boards and Harnesses

##### All Models

Top Sensor Board	Part No.
12V Wake/Sleep Only (MCxxx4)	409224CB
All Others	409222CB
Bottom Sensor Board	Part No.
12V Wake/Sleep Only (MCxxx4)	409223CB
All Others	409222CB

##### Current Configurations

Main Logic Board		Harness Part No.	
PC Board / Communications Description	2600/2800/7200 Part No.	30 pin Commun./ Power	16 pin Commun./ Power
<b>110VAC (MCXXX1) After Mar. 2007</b> - Pulse & 110VAC Power - Vend Serial	<b>408053CB</b>	<b>408732</b> <b>408732</b>	---- ----
<b>24VAC/VDC (MCXXX2)</b> - MDB - Pulse & 24VAC Power	<b>409248CB</b>	<b>408730</b> <b>408731</b>	---- ----
<b>12V Multi-interface (MCXXX3)</b> - MDB - ICT - Pulse	<b>409226</b>	---- ---- ----	<b>408720</b> <b>408721</b> <b>408722</b>
<b>12V MDB w/ Wake/Sleep (MCXXX4)</b>	<b>409273CB</b>	----	<b>408720</b>

##### Prior to March 2007

Main Logic Board		Harness Part No.	
PC Board / Communications Description	2600/2800/7200 Part No.	18 Pin Commun.	6 Pin Pulse / Power
<b>110VAC (MCXXX1)</b> - Pulse & 110VAC Power - Vend Serial - Ardac2 Serial	<b>27130</b>	---- ---- <b>027281</b>	<b>027205</b> <b>027205</b> <b>027205</b>

#### MC Series Cashboxes

Item	Description	2600 / 2800 Part No.	7200 Part No.
1	300 Note	SUB/4642	SUB/9431
2	500 Note	SUB/4646	SUB/9403
3	700 Note	SUB/4647	-----
4	900 Note	SUB/4648	-----
5	1100 Note	SUB/4649	-----

# SECTION 7: PC BOARD INTERFACE CONNECTIONS

## MC2600/MC2800/MC7200 110 VAC Pulsed Interface (30 Pin)

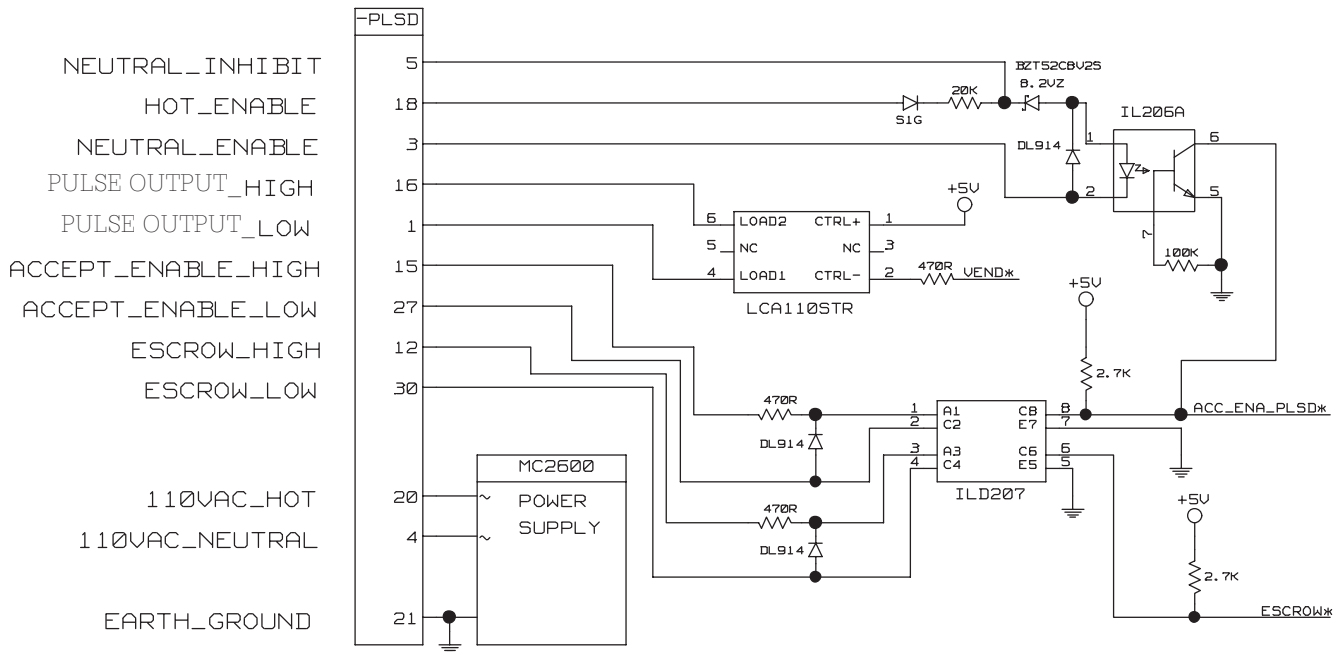

## MC2600/MC2800/MC7200 110 VAC Vend Serial Interface (30 pin)

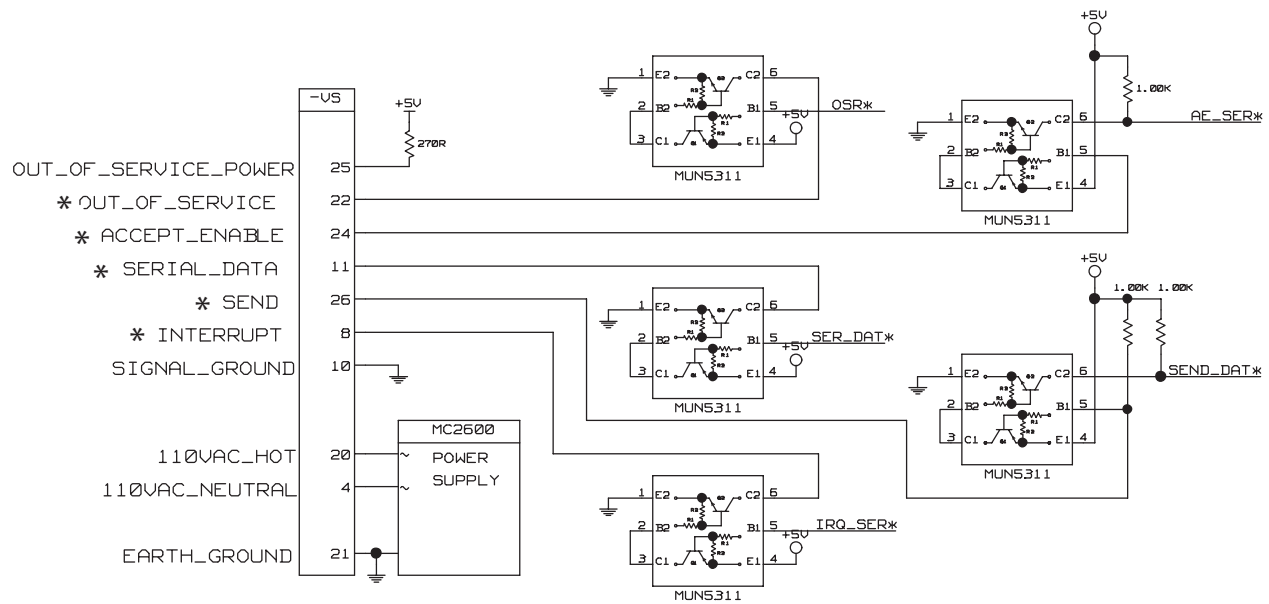

NOTE: \* means output/input is active low.

NOTE: Pin 21 Ground of the 30 pin power connector and the metal mounting plate must be connected to earth ground

# SECTION 7: PC BOARD INTERFACE CONNECTIONS

## MC2600/MC2800/MC7200 24 VAC Pulsed Interface (30 Pin)

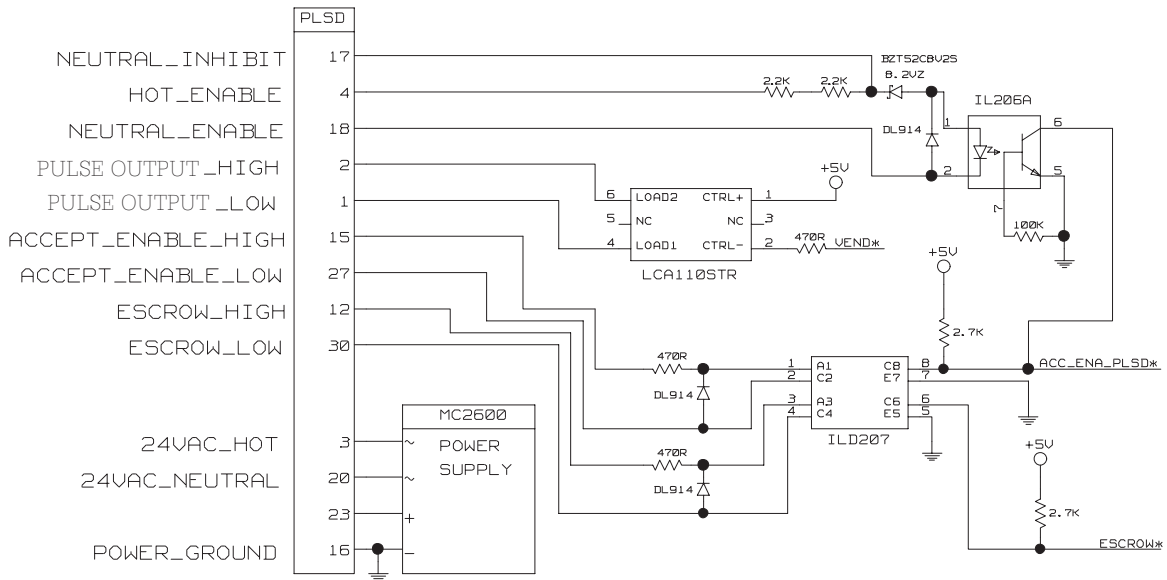

## MC2600/MC2800/MC7200 24 DC MDB Interface (30 Pin)

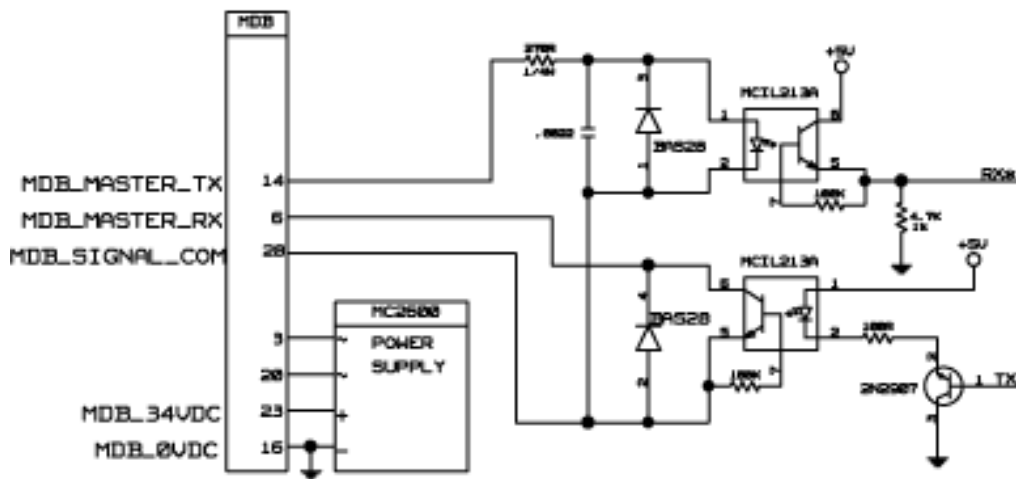

Note: Pin 21 Ground of the 30 pin power connector and the Metal mounting plate must be connected to earth ground

## SECTION 7: PC BOARD INTERFACE CONNECTIONS

### MC2600/2800/7200 12V MDB Interface & MDB w/Wake/Sleep (16 Pin)

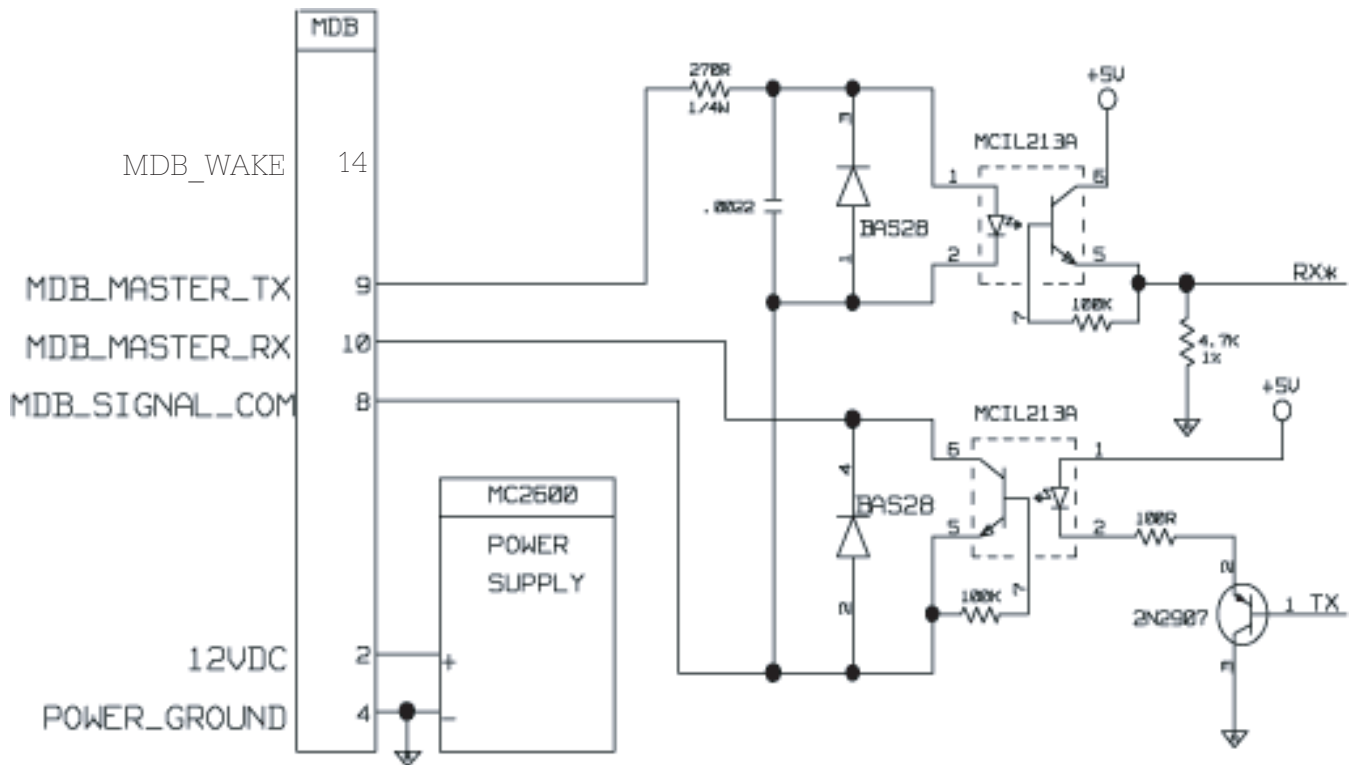

### MC2660/2800/7200 12V Ardac2/ICT Serial Interface (16 Pin)

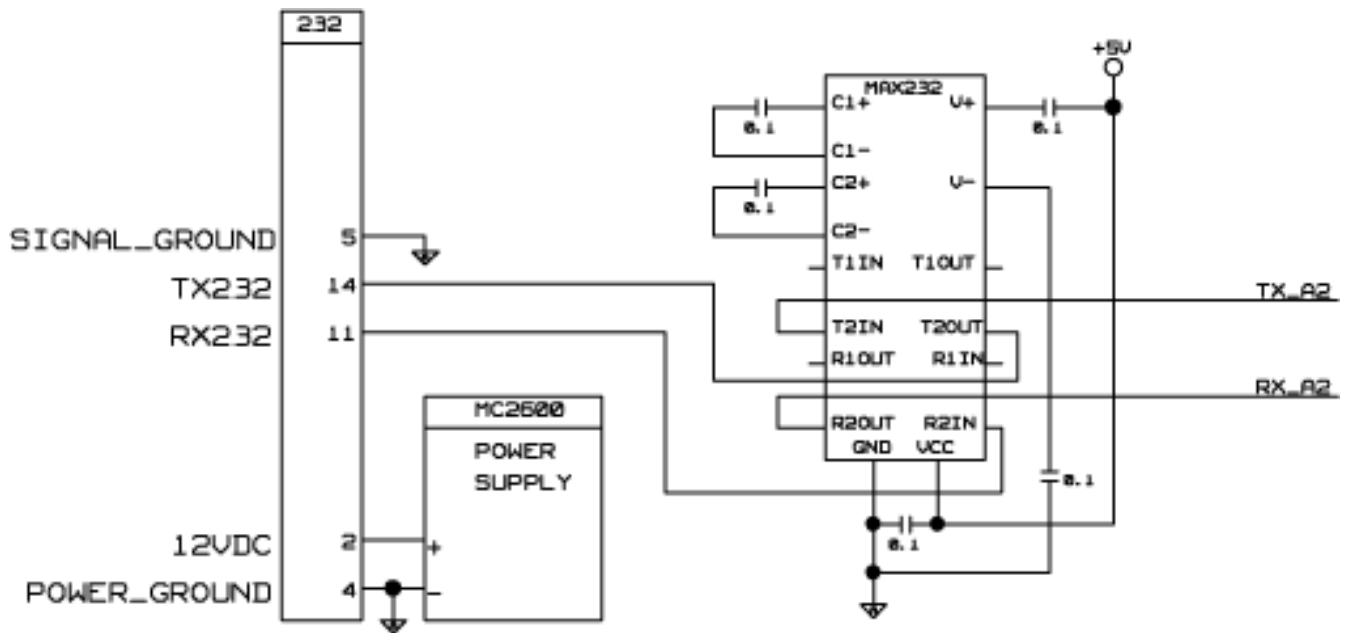

## SECTION 7: PC BOARD INTERFACE CONNECTIONS

### MC2600/2800/7200 12V Pulse Interface (16 Pin)

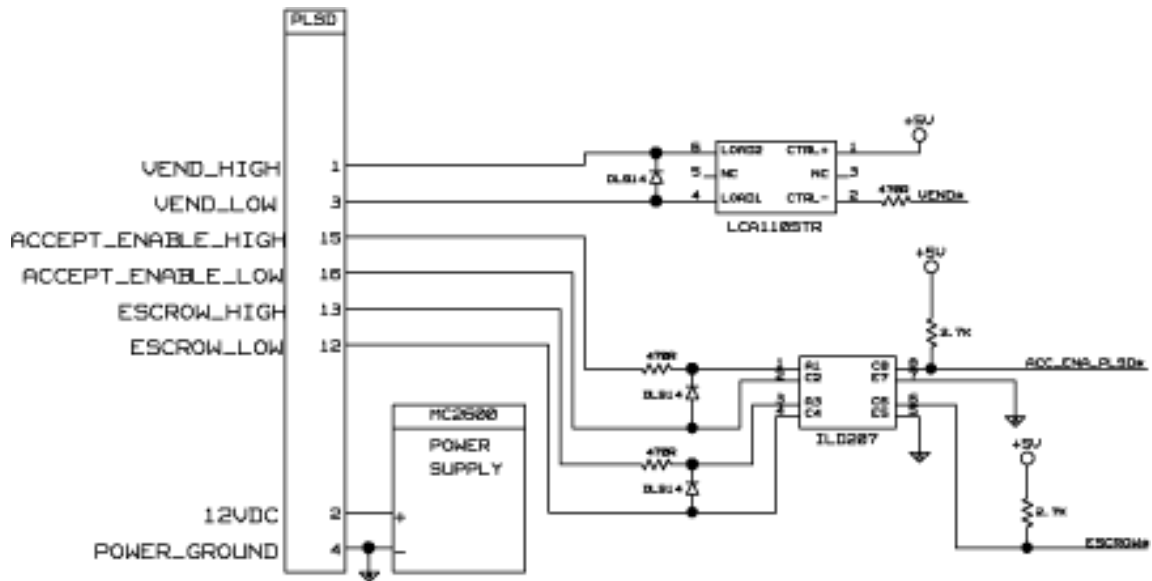



## SECTION 8: HARNESS INTERFACES

### 110 VAC Pulse/110VAC Power, Pulse Harness for 18 Pin L.B. Harness #027205

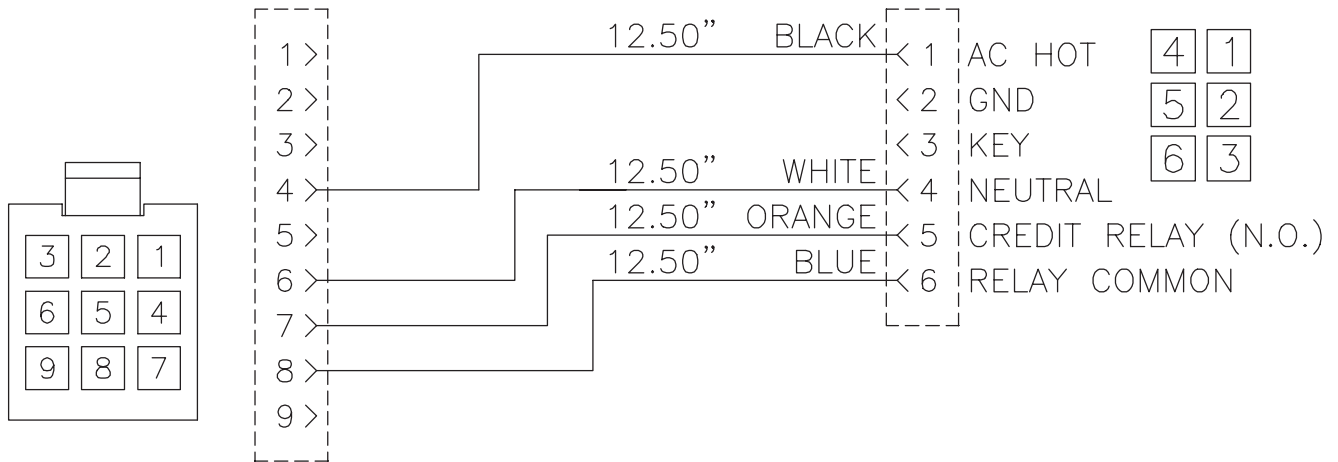

### 110VAC Ardac 2 Serial Communications for 18 Pin L.B. Harness #027281

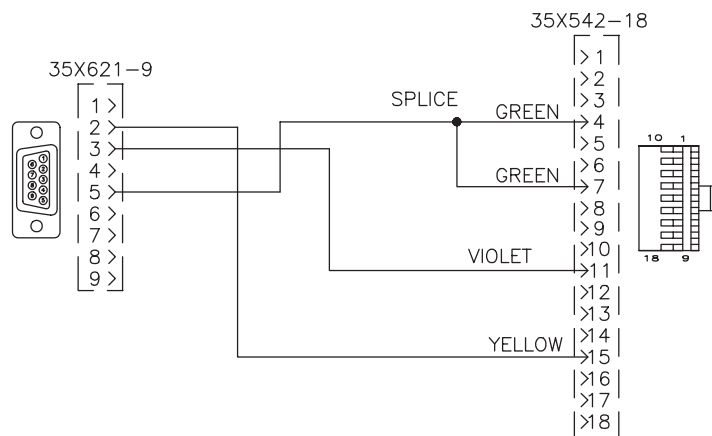

# SECTION 8: HARNESS INTERFACES

## 24 VDC MDB Communications and Power Harness # 408730

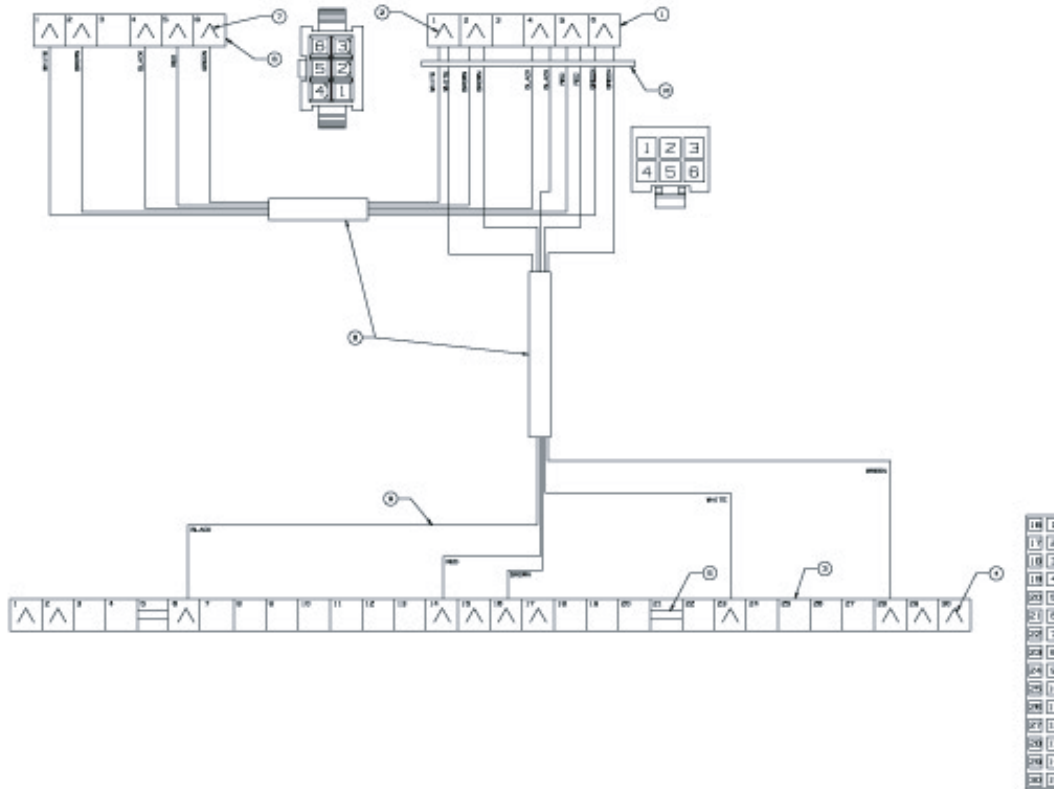

## ICT, Pulse, Ardac 2 Communications & Power Harness # 408721

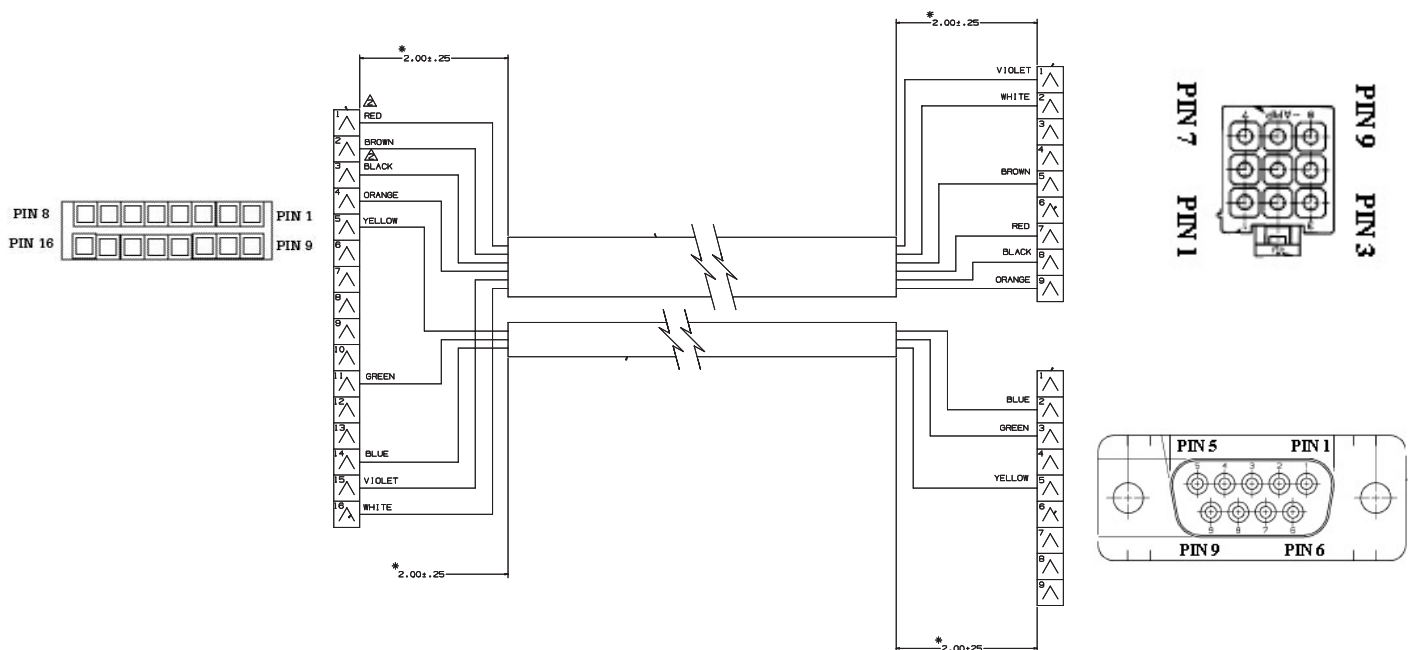

# SECTION 8: HARNESS INTERFACES

Harness # 408720 12V MDB Communications & Power with & without Wake/Sleep

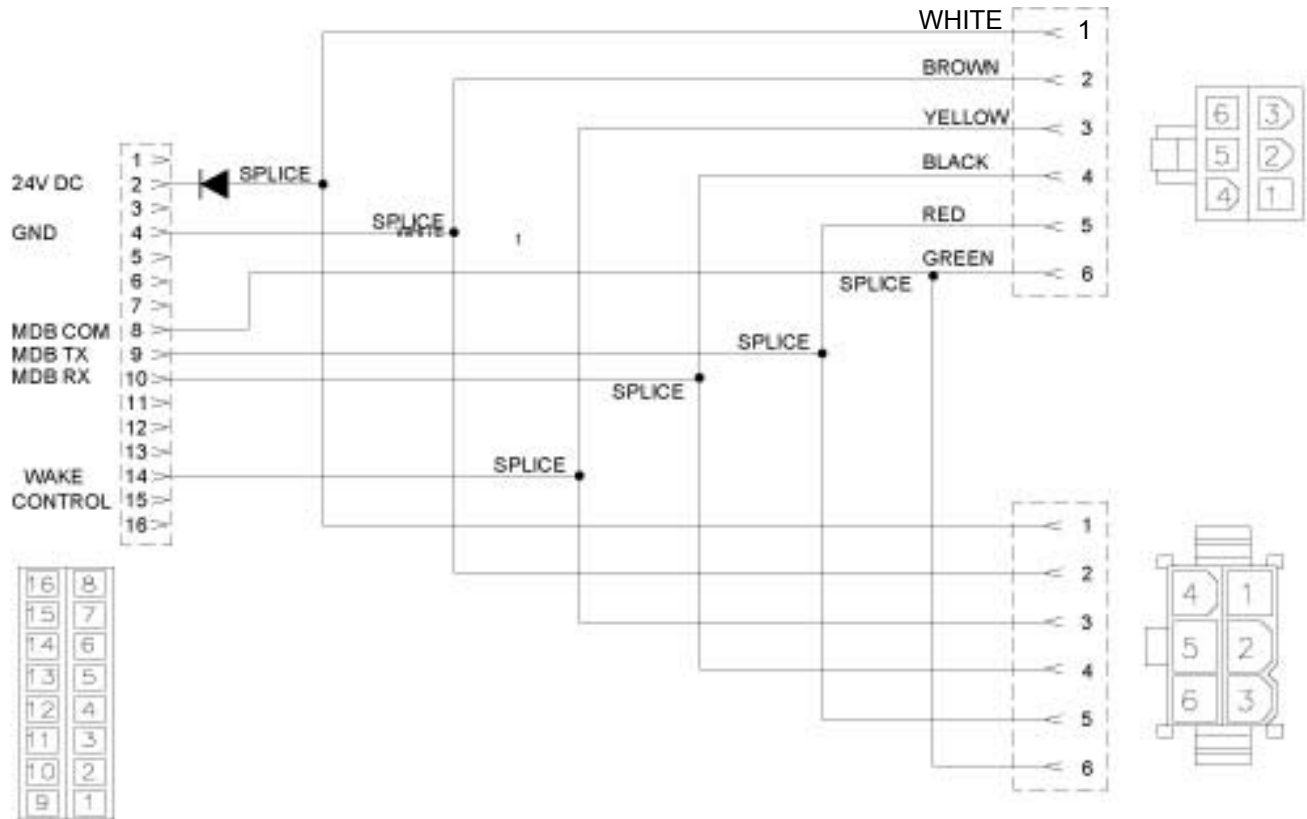

## 24VAC Pulse & Power Harness # 408731

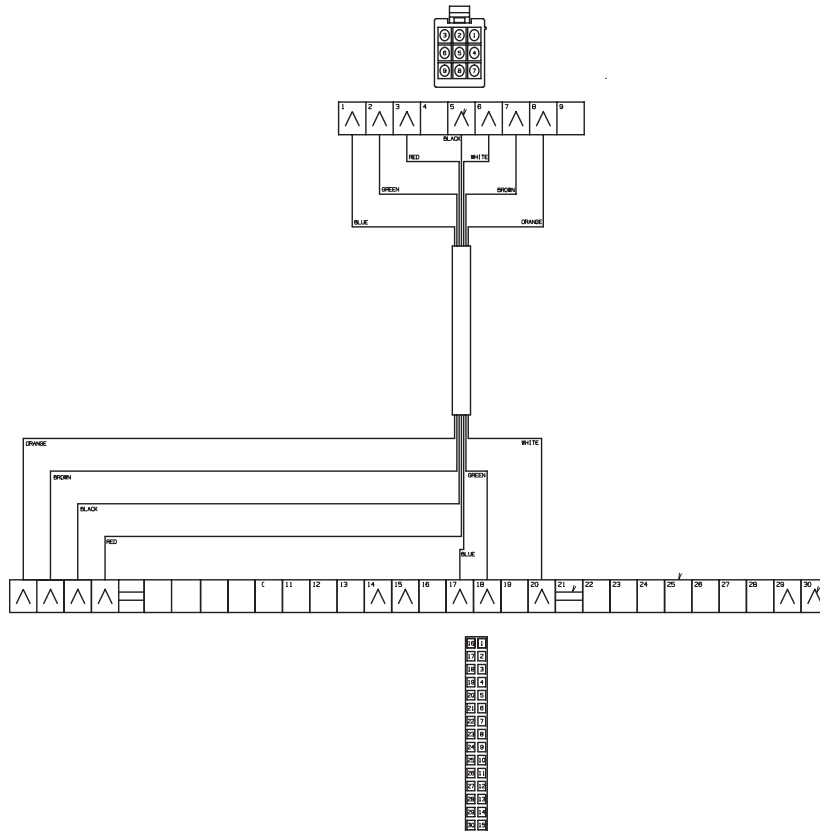

## 2600/2800 110 VAC Pulse w/ Wall Plug Power Accessory Kit #408903 Harness

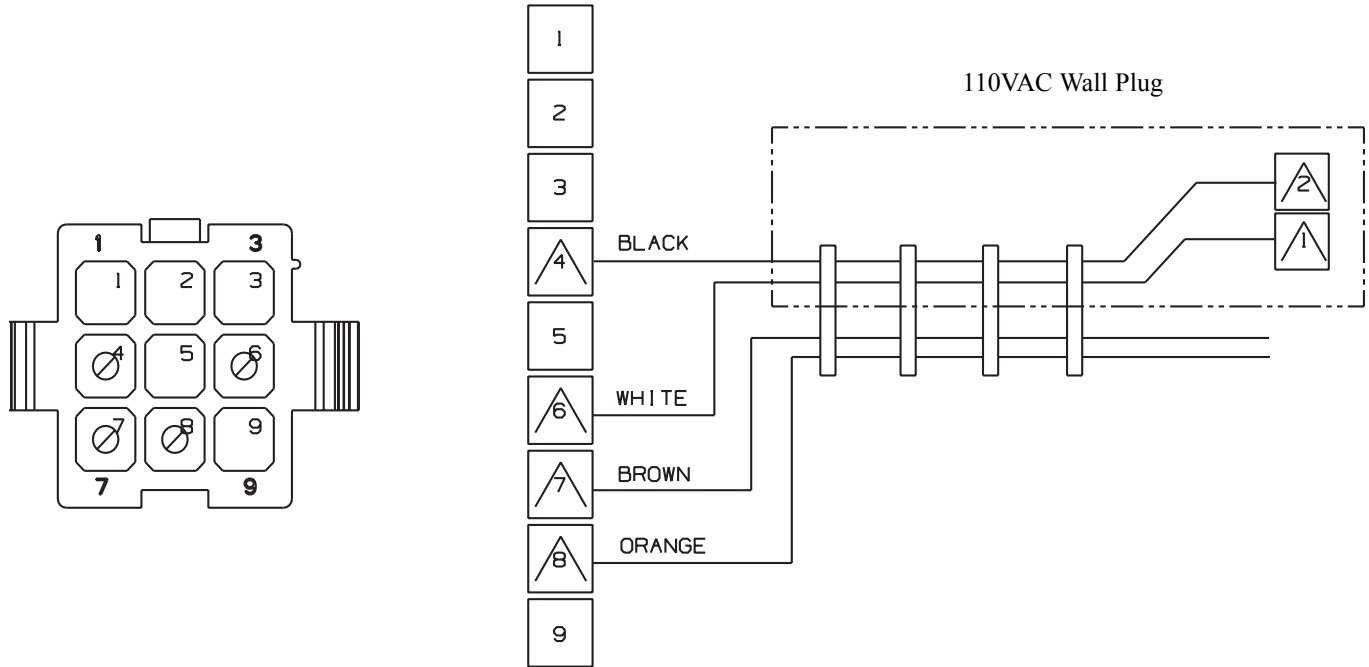

## 110 VAC Pulse/Power Harness # 408732

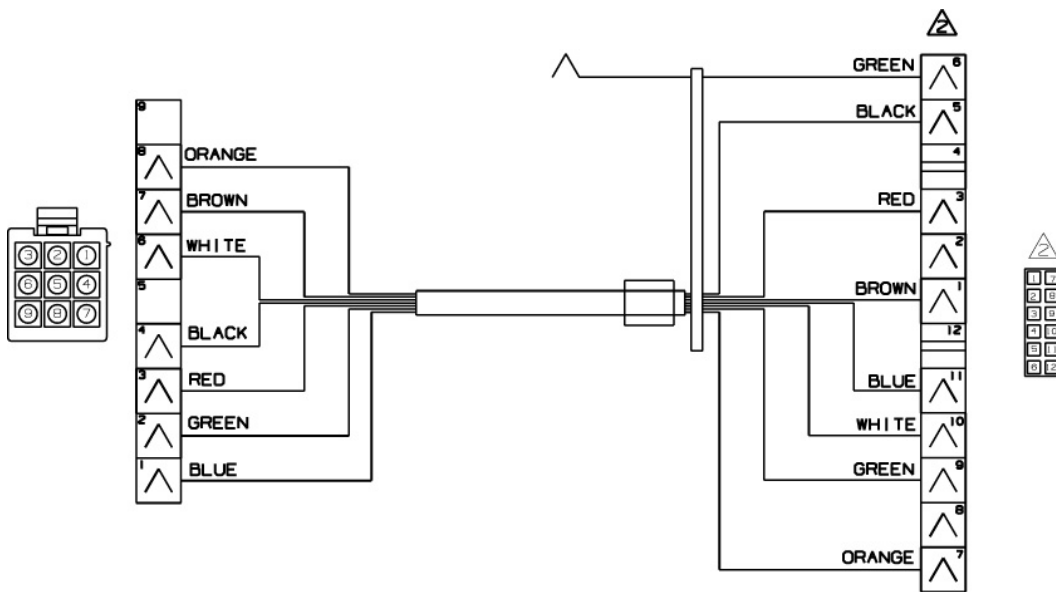

## Technical Support-Contact Information

### **USA**

Coin Acceptors, Inc.

Phone: 800-325-2646

Email: [techsupport@coinco.com](mailto:techsupport@coinco.com)

Web Site: [www.coinco.com](http://www.coinco.com)

### **CANADA**

Coin Acceptors Canada

Phone: 1-800--387-9300

Email: [techsupport@coinco.com](mailto:techsupport@coinco.com)

Web Site: [www.coinco.com](http://www.coinco.com)

*Or contact your local Coinco Distributor or Service Center.*



**Coin Acceptors, Inc.**  
300 Hunter Avenue  
St. Louis, MO 63124-2013  
USA  
314 725-0100  
(800) 325-2646